

SHARP

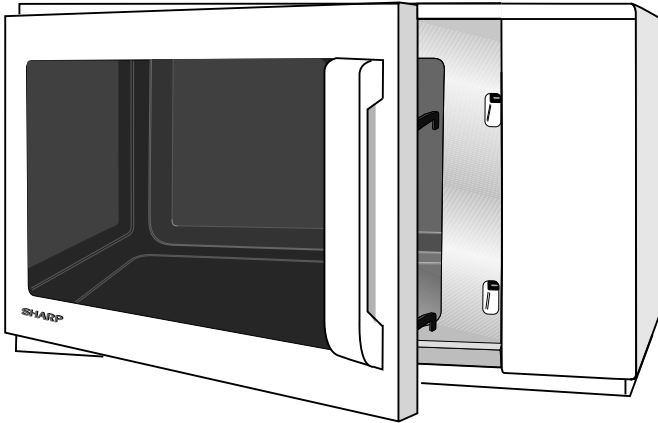

Model

———— **R-23AM** ————

COMMERCIAL MICROWAVE OVEN OPERATION MANUAL

Original Instruction

This operation manual contains important information which you should read carefully before using your microwave oven.

IMPORTANT: There may be a serious risk to health if this operation manual is not followed or if the oven is modified so that it operates with the door open.

INTELLIGENT THINKING

OVEN

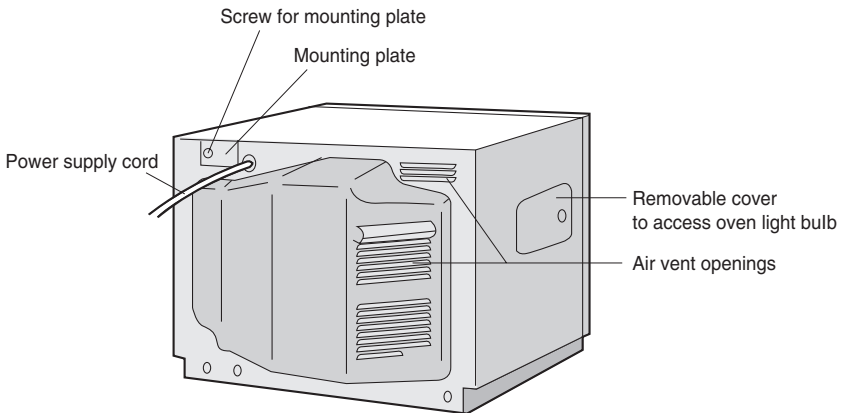
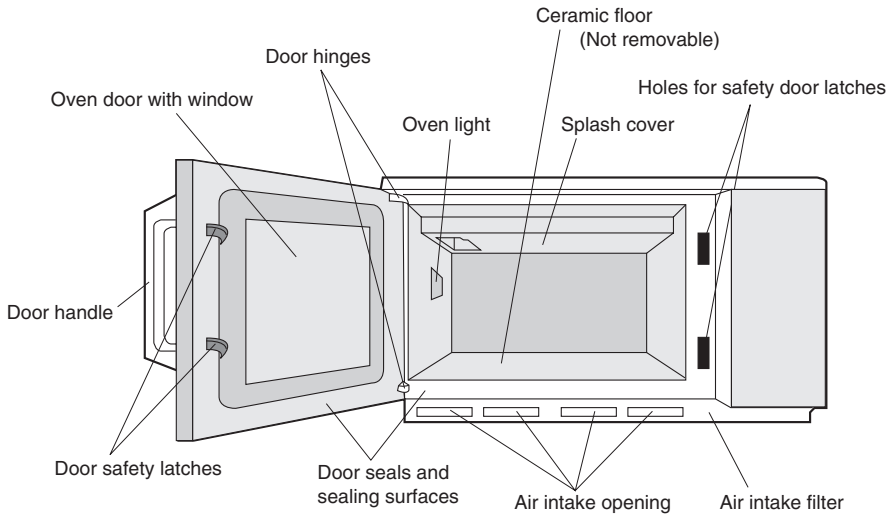

ACCESSORIES:

Check to make sure the following accessories are supplied:

- Operation manual
- Caution sheet (Special Instructions and Warnings)

CONTROL PANEL

DISPLAY AND INDICATORS

- ① Cook indicator:
This indicator shows cooking in progress.
- ② TIME display: Lighted digital display
- ③ POWER LEVEL display:
Percentage of microwave power is indicated.

OPERATING BUTTONS

- ④ HIGH (100 %)
 - ⑤ MEDIUM (50 %)
 - ⑥ MED LOW (20 %)
 - ⑦ DEFROST (10 %)
 - ⑧ TIME CONTROL:
Rotate the control to enter cooking time
 - ⑨ START button
- MICROWAVE POWER LEVEL buttons

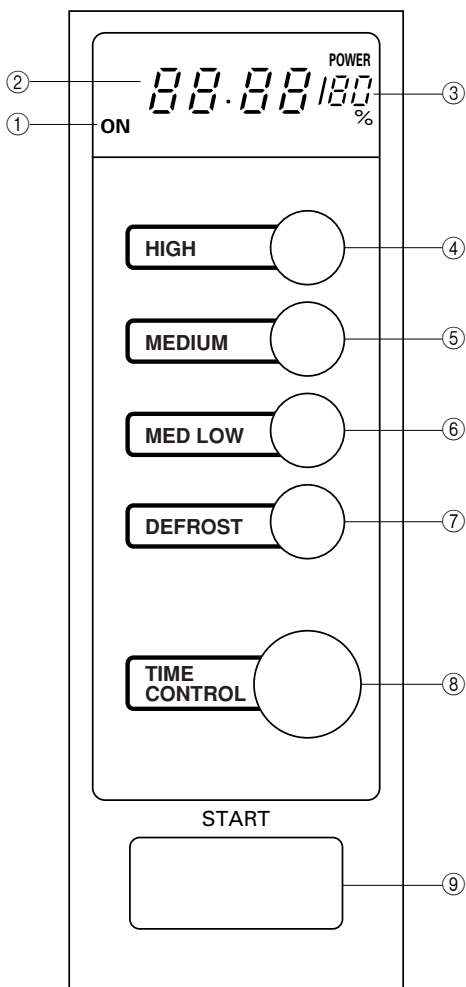

C ONTENTS

○ Oven Features with Control Panel	1 - 2
○ Contents	3
○ Important Safety Instructions	4
○ Installation	5
○ Before Operation	6
○ How to Operate the Oven:	
Manual Cooking	6
Note for manual cooking	7
Time cook	7
Defrost	7
Other Convenient Features	8
Repeat cook	8
Information with error messages	8
○ Cooking Advice:	
Suitable Cookware	9
Food Handling & Preparation	10
Advice for Defrosting	11
Advice for Reheating	12
○ Charts:	
Defrosting Chart	13 - 14
Cooking Chart	15 - 17
Reheating Chart	18 - 21
○ Cleaning & Maintenance	22 - 23
○ Troubleshooting	24
○ To replace the mains plug	25
○ Calling for service	25
○ Specifications	26

I

MPORTANT SAFETY INSTRUCTIONS

IMPORTANT: PLEASE READ CAREFULLY AND KEEP FOR FUTURE REFERENCE.

This appliance is intended to be used by expert or trained user in shops, in light industry and on farms, or for commercial use by lay persons.

This oven is designed to be used on a countertop only. It is not designed to be built into a kitchen unit. Do not place the oven in a cabinet.

The electrical outlet must be readily accessible so that the unit can be unplugged easily in an emergency.

If smoke or burn is observed: Keep the oven door closed and switch off the power by disconnecting the plug from the socket in order to stifle any flames. Failure to follow this procedure may result in fire and oven damage.

Ensure there is a minimum of free space above the oven of 25 cm.

This appliance is not intended for use by persons (including children) with reduced physical, sensory or mental capabilities, or lack of experience and knowledge, unless they have been given supervision or instruction concerning use of the appliance by a person responsible for their safety.

Children should be supervised to ensure that they do not play with the appliance.

WARNING: Only allow children to use the oven without supervision when adequate instructions have been given so that the child is able to use the oven in a safe way and understands the hazards of improper use.

WARNING: If the door or door seals are damaged, the oven must not be operated until it has been repaired by a competent person.

WARNING: Never adjust, repair or modify the oven yourself. It is hazardous for anyone other than a competent person to carry out any service or repair operation which involves the removal of a cover which gives protection against exposure to microwave energy.

If the power supply cord of this appliance is damaged, it must be replaced by an authorised SHARP service agent in order to avoid a hazard.

WARNING: Liquids and other foods must not be heated in sealed containers since they are liable to explode.

WARNING: Microwave heating of beverages can result in delayed eruptive boiling, therefore care must be taken when handling the container.

Do not cook eggs in their shells, and whole hard boiled eggs should not be heated in microwave ovens since they may explode even after microwave cooking has ended. To cook or reheat eggs which have not been scrambled or mixed, pierce the yolks and the whites, or the eggs may explode. Shell and slice hard boiled eggs before reheating them in the microwave oven. Utensils should be checked to ensure that they are suitable for use in the oven. See page 9. Use only microwave safe containers and utensils on microwave modes.

WARNING: The contents of feeding bottles and baby food jars must be stirred or shaken and the temperature checked before consumption, in order to avoid burns.

When heating food in plastic or paper containers, keep an eye on the oven due to the possibility of ignition.

Clean the oven at regular intervals and remove any food deposits.

Failure to maintain the oven in a clean condition could lead to deterioration of the surface that could adversely affect the life of the appliance and possibly result in a hazardous situation.

See instructions for cleaning door seals, cavities and adjacent parts on page 22-23.

The oven should not be cleaned with a water jet.

Use oven gloves when removing food from the oven to prevent burns.

The microwave oven should not be left unattended during operation. Power levels that are too high, or cooking times that are too long, may overheat foods resulting in a fire.

A separate circuit serving only this appliance should be provided.

Oven Use:

- The oven is for food preparation only.
Never operate when empty.
- Do not leave or store anything inside the oven when not in use.
- Never attempt to use the oven with the door open.
It is important not to tamper with the door safety latches. This may result in exposure to microwave energy.
- Never operate the oven with any object caught in the door sealing surfaces, this again may cause microwave leakage.
- Do not insert fingers or objects in the holes of the door latches or air vent openings as this may damage the oven and cause an electric shock.
- If water or food drops inside the air vent openings switch off the oven immediately, unplug it and call a Service Technician appointed by SHARP.
- Never attempt to move the oven while it is operating.
- Do not use the oven near a steamer or a fryer.
- Always wipe up spills on the ceramic floor and splashes on the walls after cooking. If you leave grease on the ceramic floor and walls it may overheat, smoke or even catch fire when next using your oven.
- After each use wipe the splash cover on the ceiling of the oven with a soft damp cloth to remove any splashes. If you leave grease on the splash cover it may overheat, smoke or even catch fire when next using your oven.

WARNING:

Pacemaker: If you have a heart pacemaker, consult your doctor or the pacemaker manufacturer prior to oven use.

Liquids: Take care when microwaving liquids and beverages. To prevent delayed eruptive boiling of liquid and possible scalding: Stir liquid prior to and during heating/reheating, let liquid stand in the oven at the end of cooking.

I NSTALLATION

⚠ WARNING:

Inspect the Oven:

Check the oven carefully for damage before and regularly after installation.

- Make sure the door closes properly, that it is not misaligned or warped.
- Check the hinges and door safety latches are not broken or loose.
- Ensure the door seal and sealing surfaces are not damaged.
- Inspect the oven interior and door for dents.

Caution Sheet:

Always keep the caution sheet (Special Instructions and Warnings) close to the oven for your reference.

Important:

If any damage is apparent, do not operate the oven in any way. Contact your dealer or an authorised Service Technician appointed by SHARP.

- 1 Remove all packing materials. Remove the protective film (blue film) from the outer case cabinet (if covered). Do not remove the plastic film from the inside of the oven window as this protects it from dirt.
- 2 Place oven on a secure, level surface, strong enough to take the oven weight, plus the heaviest item likely to be cooked in the oven.
Do not place this oven in a position which is not easily accessible. To position the oven too high can be dangerous because food can not be removed safely.
- 3 Ensure there is a minimum free space above the oven of 25 cm.
- 4 Do not place the oven where heat, moisture or high humidity are generated, (for example, near or above a conventional oven) or near combustible materials (for example, curtains). Do not block or obstruct air vent openings, as obstructions may ignite due to the emission of hot air.
- 5 Make sure the power supply cord is undamaged and that it does not run under the oven or over any hot or sharp surfaces.
- 6 The socket must be readily accessible so that it can be easily unplugged in an emergency.
- 7 Do not use the oven outdoors.
- 8 Two same oven models can be installed together by placing one on top of another. Follow these instructions.
- 8-1 Place the oven A and position the oven B on top of the oven A as shown in the figure A.
- 8-2 Remove the single screw (a) holding the mounting plate A to the rear cabinet of the oven A. And remove the mounting plate A.
- 8-3 Remove the single screw (b) from the rear cabinet of the oven B, as shown in the figure A.
- 8-4 Reinstall the mounting plate A to the rear cabinet of the oven B with the single screw (b) removed, as shown in the figure A.
- 8-5 Hold the mounting plate A to the rear cabinet of the oven A with the single screw (a), as shown in the figure A.
- 8-6 Remove the screw (a) holding the mounting plate B to the rear cabinet of the oven B. And remove the mounting plate B from the oven B. See the figure A.
- 8-7 Install the screw (a) to its position again.
- 8-8 Remove the screw (c) from the oven A.
- 8-9 Remove the screw (d) from the oven B.

- 8-10 Turn the removed mounting plate B over and then using the removed screw (c) and (d), attach the mounting plate B, as shown in the figure A.

Figure A

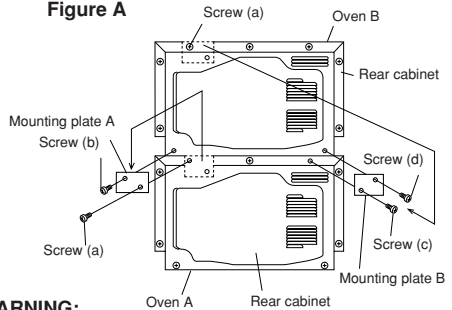

WARNING:

In situations where two ovens are installed together by placing one on top of another,

- 1) Use the two mounting plates for fixing the two ovens.
- 2) Make sure that the power supply cord is not caught between the two ovens.
- 3) Do not install more than one oven on top of another.
- 4) Do not lose the removed screws.

BUILDING-IN-KIT

This oven is not designed to be built into a kitchen unit.

IMPORTANT! ELECTRICAL CONNECTION

- Do not allow water to come into contact with the power supply cord or plug.
- Insert the plug properly into the socket as the plug may otherwise overheat and catch fire.
- Do not connect other appliances to the same socket using an adaptor plug as it may cause the wiring to overheat and catch fire.
- If the plug or socket is loose or the power supply cord is damaged, do not operate the oven, it must be replaced by the special power cord. Contact your dealer or a Service Technician appointed by SHARP.
- A defective plug, power supply cord or socket may overheat and catch fire during operation or cause an electrical shock.
- When removing the plug from the socket always grip the plug, never the mains lead as this may damage the power supply cord and the connections inside the plug.
- The product is fitted with a non-rewireable (moulded) plug. Should it not be suitable for the socket outlet in your kitchen, remove the plug and fit an appropriate type, observing the wiring code given in "To replace the mains plug" on page 25.

The fuse from a cut-off plug should be removed and the plug disposed of in safe manner. Under no circumstances should the cut-off plug be inserted into a socket outlet as serious electrical shock may occur. The plug must not be used without the fuse cover fitted.

When replacing the plug please ensure that you use a BSI or ASTA approved plug to BS1363, this should be fitted with a brown coloured 13 amp fuse approved by BSI or ASTA to BS1362. If you have any doubt about electrical connection seek the help of a qualified electrician.

⚠ WARNING

THIS APPLIANCE MUST BE EARTHED.

To wire an appropriate plug, follow the wiring code given in "To replace the mains plug" on page 25.

B

BEFORE OPERATION

- When you first connect the microwave oven to an electrical socket, the digital display will show .
- You can input the buttons and timer control only when the door is closed.
- Oven lamp and fan motor work for 1 minute whenever the door is opened or after cooking.
- The programme is cancelled when any buttons or timer control are not pressed for more than 3 minutes during programming.
- To cancel the programme during cooking, open and close the door twice.
- will appear on the display after the time reaches zero. It will disappear when the oven door is opened.

H

HOW TO OPERATE THE OVEN

Introduction: Microwaves are absorbed by water, sugar and fat in food and cause them to vibrate. This creates heat by friction, in the same way your hands get warm when you rub them together.

Outer areas of food are heated by microwave energy, and remaining portions by conduction. It is, therefore, important to **turn, rearrange** or **stir** food to ensure even heating. Where recommended, allow food to **stand**, this is not optional but necessary to ensure thorough cooking

and is particularly important for dense food, such as joints of meat.

Microwaves pass through non-metallic dishes and utensils and heat the food inside the dishes. Microwaves are reflected by metal. The oven is lined with metal and has a fine metallic mesh in the door to prevent microwave leakage. Metallic dishes are not suitable for microwaving.

For your reference, see COOKING ADVICE on pages 9 -12.

MANUAL COOKING

Your oven can be programmed up to 30 minutes and has 4 preset power levels.

LEVELS	MICROWAVE POWER	WATT
HIGH	100 %	1900
MEDIUM	50 %	950
MED LOW	20 %	380
DEFROST	10 %	190

The input unit of cooking (defrosting) time varies from 2 seconds to 30 seconds. It depends on the length of the cooking (defrosting) time as shown on the table below.

<u>Cooking time</u>	<u>Increasing unit</u>
0-60 seconds	2 seconds
60 seconds-3 minutes	5 seconds
3-10 minutes	10 seconds
10-30 minutes	30 seconds

NOTE FOR MANUAL COOKING

1. It is not necessary to touch MICROWAVE POWER LEVEL button for 100%.
2. During cooking mode, the oven stops when the door is opened, and the programme is cancelled if any buttons or timer control are not touched within 1 minute after the door is opened.
3. The remaining cooking time is cancelled when the door is closed and opened during stop mode.
4. If you rotate the control counterclockwise, the cooking time will decrease from 30 minutes by degrees.

TIME COOK

* Example: If you want to cook for 2 minutes and 30 seconds at MEDIUM.

Step 1

Enter cooking time by rotating the TIME CONTROL (2 min. 30 sec.)

TIME CONTROL



Step 2

Select power level by pressing the POWER LEVEL button.

MEDIUM



Step 3

Press START button once to start cooking.

START

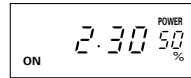

The display will start to count down to zero.

TIP: To help you decide power level and time, see the COOKING CHART and REHEATING CHART on pages 15-21.

DEFROST

You can defrost the food by using the DEFROST button.

* Example: To defrost 450g (1lb.) of beef joint for 10 minutes.

Step 1

Enter desired defrost time. (10 min.)

TIME CONTROL



Step 2

Press the DEFROST button.

DEFROST



Step 3

Press START pad once to start defrosting.

START



The display will start to count down to zero. And turn over 4-5 times during defrosting.

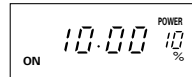

TIP: Allow food to stand a few minutes after defrosting to equalize the temperature for better cooking results.

Check food after standing. If additional time is needed, continue to defrost with DEFROST button and additional time. Foods that are the same thickness throughout defrost better. If foods have varied thickness, it may be necessary to shield the thin edges with small flat pieces of aluminum foil to prevent overdefrosting.

You can defrost foods by using the MED LOW button.

To help you decide power level and time, see the DEFROSTING CHART on pages 13-14.

OTHER CONVENIENT FEATURES

REPEAT COOK

Your oven can memorize the last cooking time in each power level. If you use this function, you have no need to enter the cooking time.

Example: If you want to use this function at 100%. (The last cooking time is 10 minutes.)

Step 1

Select desired power level (HIGH).

HIGH



Check the last programme



Step 2

Press START pad once to start cooking.

START



The display will start to count down to zero.

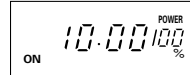

INFORMATION WITH ERROR MESSAGES

If ERROR messages are displayed, follow the instructions below.

ERROR MESSAGES	
EE1 EE2 EE3 EE6 EE8 EE0 EE10 EE16	Please contact your dealer or an authorized service agent because the oven is malfunctioning.
EE7	Exhaust air temperature is too high. Check that nothing is blocking the vent openings and air intake openings or that room temperature is too hot or that oven cavity is empty during operation. Correct and try again after a few minutes.
EE17	Magnetron temperature is too high. Open and close the door twice, and then try again after a few minutes.

COOKING ADVICE



WARNING - Always attend the oven when in use.









Carefully follow the SHARP Operation Manual at all times. If you exceed recommended cooking times and/or use power levels that are too high, food may overheat, burn, and in extreme circumstances, catch fire and damage the oven.

- The microwave power level will default to 100% unless you press the **POWER LEVEL** button for the desired setting. Take care when heating foods with high sugar or fat content, e.g. Christmas pudding, mince pies and fruit cakes. Before use, check that utensils are suitable for use in microwave ovens.
- **Lids:** Always remove lids from food jars and containers before using them in the oven. If you do not, steam and pressure will build up inside and the container may explode. Take care when heating contents in babies bottles, see page 10.
- Do not cook eggs in their shell as they will explode. **Do not** heat canned potatoes in the microwave oven as they may burst.

For microwaving, use only those utensils suitable for microwave cookery as indicated below.

A variety of cookware can be used for microwaving. Round/oval dishes rather than square/oblong ones are recommended, as food in the corners tends to overcook.

SUITABLE COOKWARE

COOKWARE	SUITABLE FOR MICROWAVING
Heat resistant glass, (e.g. Pyrex®, Fire King®, Corning Ware®). 	YES
Microwave-safe plastic cookware. 	YES
Microwave cling film , microwave roasting bags. 	YES Microwave cling film and bags must be vented for steam to escape, pierce in 4-5 places. Do not use plastic or metal ties as they may melt or catch fire due to 'arcing'.
Heat resistant china and ceramics. 	YES Except for dishes with metallic decoration.
Disposable containers: Thin plastic, paper, straw and wooden containers. 	YES Always attend the oven closely. Look at the oven from time to time when cooking or reheating food in disposable containers of plastic, paper or other combustible material. Only use for warming food. Pay special attention as over-heating may cause a fire in your oven.
Kitchen paper. 	YES Always attend the oven closely. Only use to absorb fat and moisture when warming food. Pay special attention as overheating may cause a fire in your oven.
Browning dishes & self-heating packages. 	YES Always place on an up-turned plate on the turntable to prevent heat stress. Follow manufacturer's instructions. Be careful as these become very hot. Popcorn: Only use microwave popcorn within recommended packaging (follow popcorn manufacturer's instructions). Never use oil unless the manufacturer recommends and never cook for longer than instructed.
Metal cookware. 	NO
Aluminium foil & foil containers, made from "Microfoil®". 	YES Use small pieces of aluminium foil to shield food from overheating. Keep foil at least 2cm from the oven walls. Foil containers are not recommended unless specified by the manufacturer, e.g. MicroFoil®, follow instructions carefully.

⚠ Face & Hands: Always use oven gloves to remove food or cookware from the oven. Stand back when opening the oven door to allow heat or steam to disperse. When removing covers (such as cling-film), opening roasting bags or popcorn packaging, direct steam away from face and hands.

Check the temperature of food and drink and stir (before serving). Take special care when serving food to babies, children or the elderly. the contents of feeding bottles and baby food jars should be stirred or shaken and the temperature checked before consumption to avoid burns.

FOOD HANDLING & PREPARATION

Stir, turn & stand



For even cooking stir, turn or rearrange food during cooking. Where recommended, leave food to stand after cooking or defrosting.

Initial temperature



The initial temperature of food affects the amount of cooking time needed, for example, chilled food requires more cooking than food at room temperature. The temperature of the container is not a true indication of the temperature of the food or drink. Cut into foods with fillings, for example, jam doughnuts, to release heat or steam.

Piercing



Food with skin (e.g. potatoes, apples, fish, sausages, chicken), or with membrane (e.g. egg whites/yolks), must be pierced in several places before cooking or reheating. If not, steam will build up and may cause food to explode.

Arrangement



Place thickest parts of food on the outside of the dish, e.g. place the meaty ends of chicken drumsticks on the outside of the dish.

Covering



Fish, vegetables and certain other foods benefit from being covered during microwave cookery, follow recommendations where given and use vented microwave cling film or a suitable lid.

Size & shape



Food size and shape affect the amount of cooking time needed. When cooking more than one portion of the same food ensure they are of a similar size and shape.

Density & quantity



Food density and quantity affect the amount of cooking time needed, for example, potatoes require more cooking than peas; four potatoes will take longer to cook than two.

Composition & quality



Food high in fat or sugar (Christmas pudding, mince pies) requires less heating time and should be watched, over-heating can lead to fire. Use good quality ingredients for microwaving. Economical cuts of meat can be used for casseroles.

Hygiene



Food hygiene standards (storage, handling and preparation) apply to microwaving. Always store convenience foods as recommended by the food manufacturer and keep no longer than the "Use By" date.

ADVICE FOR DEFROSTING

Meat joints



Place in a flan dish, turn over at least 4-5 times during defrosting, shield any warm areas with small, flat pieces of foil. After defrosting, wrap in foil and allow meat to stand for 1-2 hours, until thoroughly defrosted.

Poultry

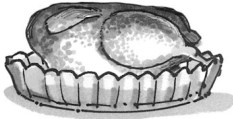

Place in a flan dish, turn over at least 3-4 times during defrosting, shield any warm areas with small, pieces of foil. After defrosting, wrap in foil and allow poultry to stand for 1-2 hours, until thoroughly defrosted.

NOTE: Do not defrost poultry with giblets.

Steak, Chops & Chicken Portions



Place in a flan dish, separate during defrosting and turn over at least 2-3 times. Shield if necessary.

Cubed & Minced Meat



Place in a bowl, remove defrosted parts and turn over at least 3-4 times during defrosting.

Whole fish & Fillets



Place in a flan dish, separate and turn over at least twice during defrosting. Shield if necessary.

Prepacked Frozen Foods



Remove packaging, including any foil and place in a suitable dish.

NOTES:

- To defrost food, use either MED LOW (20%) or DEFROST (10%) microwave power.
- Shield warm areas with small pieces of foil if necessary.
- It is important to turn food over, separate (where appropriate) and rearrange to ensure even defrosting.
- Standing time is necessary after defrosting to ensure thorough defrosting.

ADVICE FOR REHEATING



WARNINGS:

Oil & Fat: Never heat oil or fat for deep frying as this may lead to overheating and fire. Stand back when opening the oven door to allow heat or steam to disperse. When removing covers (such as cling-film), opening roasting bags or popcorn packaging, direct steam away from face and hands.

Never heat liquids in narrow-necked containers, as this could result in the contents erupting from the container and may cause burns.

- Remove food from foil or metal containers before reheating.
- Reheating times will be affected by the shape, depth, quantity and temperature of food together with the size, shape and material of the container.
- To avoid overheating and fire, special care must be taken when reheating foods with a high sugar or fat content, for example, mince pies, Christmas pudding.
- Canned potatoes should not be heated in the microwave oven, follow the manufacturers' instructions on the can.

Plated meals



Remove any poultry or meat portions, reheat these separately, see below. Place smaller items of food to the centre of the plate, larger and thicker foods to the edge. Cover with vented microwave cling film and reheat on MEDIUM (50%), stir/rearrange halfway through reheating. Ensure thoroughly reheated before serving.

Casseroles



Cover with vented microwave cling film or a suitable lid, reheat on MEDIUM (50%). Stir frequently to ensure even reheating.

Poultry portions



Place thickest parts of the portions on the outside of the dish, cover with microwave cling film and reheat on MEDIUM (50%). Turn over halfway through reheating.

NOTE: Ensure poultry is thoroughly reheated, before serving.

Sliced meat



Cover with vented microwave cling film and reheat on MEDIUM (50%). Rearrange at least once to ensure even reheating.

NOTE: Ensure meat is thoroughly reheated before serving.

Pies



Place pies on plate or in a flan dish. Reheat meat pies and fruit pies on MEDIUM (50%).

Vegetables



Cover with vented microwave cling film or suitable lid and reheat on MEDIUM (50%). Stir at least once during reheating.

D

EFROSTING CHART

MANUAL DEFROSTING

FOOD	DEFROSTING TIME	MICROWAVE POWER LEVEL	METHOD
Beef, Lamb & Pork Joints (uncooked)	8 mins /450g (1lb)	DEFROST (10%)	<ol style="list-style-type: none"> Place on a large plate. Turn over 4-5 times during defrosting. <p>NOTE: If necessary, small pieces of aluminium foil can be used to shield small areas of meat which may become warm during defrosting.</p> <ol style="list-style-type: none"> After defrosting, wrap in foil and leave to stand for 1-2 hours or until thoroughly defrosted.
Whole Poultry (uncooked)	6-7 mins /450g (1lb)	DEFROST (10%)	As above
Minced Beef (uncooked)	3-4 mins /450g (1lb)	MED LOW (20%)	<ol style="list-style-type: none"> Place on a plate or in a flan dish. Turn over 2-3 times during defrosting, removing defrosted mince each time. After defrosting, cover any frozen mince remaining with aluminium foil for 15-20 minutes or until thoroughly defrosted.
Sausages (uncooked) thick thin	5-6 mins 3-4 mins /450g (1lb)	DEFROST (10%)	<ol style="list-style-type: none"> Place on a large plate, in a single layer if possible. Turn over 2-3 times during defrosting and separate if necessary. After defrosting, cover with aluminium foil and leave to stand for 15-20 minutes or until thoroughly defrosted.
Bacon (uncooked)	5-6 mins /450g (1lb)	DEFROST (10%)	<ol style="list-style-type: none"> Place on a plate. Separate and re-arrange 3-4 times during defrosting. After defrosting, cover with aluminium foil and leave to stand for 5-10 minutes or until thoroughly defrosted.
Sausage Rolls Large (cooked)	1-2 mins for 8 rolls, 375g (13oz) Total weight	DEFROST (10%)	<ol style="list-style-type: none"> Place on a large plate. Turn over and re-arrange halfway through defrosting. After defrosting, cover with foil and leave to stand for 15-30 minutes or until thoroughly defrosted.
Quiche (cooked)	5-6 mins /450g (1lb)	DEFROST (10%)	<ol style="list-style-type: none"> Place on a large plate. After defrosting, cover with foil and leave to stand for 15-30 minutes or until thoroughly defrosted.
Meat Pie (cooked)	4 mins /450g (1lb)	DEFROST (10%)	As above.
Fruit Pie/ Crumble (cooked)	3-4 mins /450g (1lb)	DEFROST (10%)	As above.
Sponge Pudding (cooked)	2-3 mins /450g (1lb)	DEFROST (10%)	As above.

D

DEFROSTING CHART

FOOD	DEFROSTING TIME	MICROWAVE POWER LEVEL	METHOD
Bread Sliced	4-5 mins /800g (1¾lb) loaf	MED LOW (20%)	<ol style="list-style-type: none">1. Arrange and separate slices on the turntable.2. Turn over, separate and re-arrange twice during defrosting. Remove defrosted slices each time.3. After defrosting, cover with foil for 5-10 minutes or until thoroughly defrosted.
Bread Buns	1-2 mins for 6 buns	DEFROST (10%)	<ol style="list-style-type: none">1. Place on turntable.2. Turn over & re-arrange halfway through defrosting.3. After defrosting, cover with foil and leave to stand for 15 minutes or until thoroughly defrosted.
Rice (cooked)	5-6 mins /450g (1lb)	MED LOW (20%)	<ol style="list-style-type: none">1. Place in a large bowl.2. Break up during defrosting, removing defrosted rice each time.3. After defrosting, cover any frozen rice remaining with foil and leave to stand for 10-15 minutes or until thoroughly defrosted.

NOTES:

- Prior to defrosting, food is frozen approx. -18°C.
- If it is necessary to shield small areas of food, use small pieces of foil.
- Only use food which is thoroughly defrosted, use a professional food thermometer to ensure acceptable temperatures have been achieved throughout.

C OOKING CHART

FOOD	COOKING TIME	MICROWAVE POWERLEVEL	METHOD
Beef: Medium (Topside, Silverside) Chilled (5°C)	8-9 mins /450g (1lb)	MEDIUM (50%)	<ol style="list-style-type: none"> 1. Place fat side down in a flan dish. 2. Turn over halfway through cooking and remove juice. 3. After cooking, wrap in foil and leave to stand for 8 minutes before serving.
Lamb, medium (fillet, shoulder, leg) Chilled (5°C)	8-9 mins /450g (1lb)	MEDIUM (50%)	As above.
Pork (loin, leg) Chilled (5°C)	12-13 mins /450g (1lb)	MEDIUM (50%)	As above.
Poultry (whole) (max.3.5kg(8lb) Chilled (5°C)	7-8 mins /450g (1lb)	MEDIUM (50%)	<ol style="list-style-type: none"> 1. Place breast side down in a flan dish. 2. Turn over halfway through cooking and remove juice. 3. After cooking, wrap in foil and leave to stand for 10 minutes before serving.
Chicken Portions			
Legs	7-8 mins	MEDIUM (50%)	<ol style="list-style-type: none"> 1. Place best side down in a single layer in a flan dish. 2. Turn over halfway through cooking, & remove juice. 3. After cooking, wrap in foil and leave to stand for 5 minutes before serving.
Breast Chilled (5°C)	9-10 mins /450g (1lb)		
Minced Beef Chilled (5°C)	5-6 mins /450g (1lb)	MEDIUM (50%)	<ol style="list-style-type: none"> 1. Place in a large bowl. 2. Stir 2-3 times during cooking. 3. After cooking cover bowl with foil and leave to stand for 2-3 minutes before serving.
Bacon Chilled (5°C)	2 mins for 8 rashers	HIGH (100%)	<ol style="list-style-type: none"> 1. Place in a single layer on a large plate. 2. Turn over halfway through cooking. 3. Leave to stand for 1 minute before serving.
Burgers Chilled (5°C)	2 mins for 4 burgers /450g (1lb)	HIGH (100%)	As above
Sausages (thick) Chilled (5°C)	2 mins for 8 sausages	HIGH (100%)	As above
(thin) Chilled (5°C)	2 mins for 12 sausages		
Sliced Gammon Chilled (5°C)	2-3 mins for 1 slice /250g (9oz)	HIGH (100%)	As above
Fish Fillet/ Steaks Chilled (5°C)	3 mins /450g (1lb)	HIGH (100%)	<ol style="list-style-type: none"> 1. Place in a single layer in a large flan dish, cover with microwave cling film and pierce in 4-5 places. 2. Leave to stand for 2-3 minutes before serving.
Trout (whole) Chilled (5°C)	5 mins /450g (1lb)	MEDIUM (50%)	As above.

C OOKING CHART

FOOD	COOKING TIME	MICROWAVE POWERLEVEL	METHOD
Rice/Pasta <i>Room</i> (20°C)	11-12 mins for 200g (7oz)	MEDIUM (50%)	<ol style="list-style-type: none"> 1. Place Rice/Pasta in a 2.5 litre casserole dish. 2. Add three times the volume of boiling water to quantity of rice. Do not cover. 3. Stir 3 times during cooking. 4. Stand for 2-3 minutes before rinsing in boiling water and serving.
Jacket Potatoes <i>Room</i> (20°C)	4-5 mins for 2 potatoes	HIGH (100%)	<ol style="list-style-type: none"> 1. Pierce each potato in several places. 2. Place on the edge of the turntable. 3. Stand for 3-4 minutes before serving.
Corn on the Cob <i>Room</i> 20°C <i>Frozen</i> -18°C	Fresh: 2-3 mins for 2 cobs Frozen: 4-5 mins for 2 cobs	HIGH (100%)	<ol style="list-style-type: none"> 1. Place in a dish, add 60ml (4tbsp) water. 2. Cover with microwave cling film pierce in 4-5 places. 3. Turn over halfway through cooking. 4. Stand for 1-2 minutes before serving.
Beans (green) <i>Fresh:</i> 20°C <i>Frozen:</i> -18°C	Fresh: 2 mins for 225g (8oz) Frozen: 2-3 mins for 225g (8oz)	HIGH (100%)	<ol style="list-style-type: none"> 1. Place in a dish, add 30ml (2tbsp) water. 2. Cover with microwave cling film and pierce in 4-5 places. 3. Stir halfway through cooking. 4. Stand for 1-2 minutes before serving.
Broccoli <i>Fresh:</i> 20°C <i>Frozen:</i> -18°C	Fresh: 2 mins for 225g (8oz) Frozen: 3 mins for 225g (8oz)	HIGH (100%)	As above
Carrots (sliced) <i>Fresh:</i> 20°C <i>Frozen:</i> -18°C	Fresh: 2 mins for 225g (8oz) Frozen: 3 mins for 225g (8oz)	HIGH (100%)	As above
Carrots (baby, whole) <i>Fresh:</i> 20°C <i>Frozen:</i> -18°C	Fresh: 2 mins for 225g (8oz) Frozen: 3 mins for 225g (8oz)	HIGH (100%)	As above
Cauliflower <i>Fresh:</i> 20°C <i>Frozen:</i> -18°C	Fresh: 2 mins for 225g (8oz) Frozen: 3 mins for 225g (8oz)	HIGH (100%)	As above
Peas <i>Fresh:</i> 20°C <i>Frozen:</i> -18°C	Fresh: 1-2 mins for 225g (8oz) Frozen: 2-3 mins for 225g (8oz)	HIGH (100%)	<ol style="list-style-type: none"> 1. Place in a dish, add 30ml (2tbsp) water. 2. Cover with microwave cling film and pierce in 4-5 places. 3. Stir halfway through cooking. 4. Leave to stand for 1-2 minutes before serving.

C

OOKING CHART

FOOD	COOKING TIME	MICROWAVE POWERLEVEL	METHOD
New potatoes <i>Room 20°C</i>	4 mins for 450g (1lb)	HIGH (100%)	<ol style="list-style-type: none"> 1. Place in a large dish, add 60ml (4tbsp) water. 2. Cover dish with microwave cling film and pierce in 4-5 places. 3. Stir halfway through cooking. 4. Leave to stand for 1-2 minutes before serving.
Mushrooms (fresh) <i>Room 20°C</i>	1 min for 225g (8oz)	MEDIUM (50%)	<ol style="list-style-type: none"> 1. Chop or leave whole as desired. 2. Place in dish, cover with microwave cling film and pierce in 4-5 places. 3. Stir halfway through cooking.
Tomatoes (fresh) <i>Room 20°C</i>	1 min for 225g (8oz)	MEDIUM (50%)	<ol style="list-style-type: none"> 1. Slice or quarter as desired. NOTE: If you wish to leave whole, pierce in several places. 2. Place in a dish or on a plate, cover with microwave cling film and pierce in 4-5 places. 3. Leave to stand for 1-2 minutes before serving.
Scrambled Egg <i>Chilled 5°C</i>	2 mins	HIGH (100%)	<ol style="list-style-type: none"> 1. Place 6 eggs (size 3), 150ml ($\frac{1}{4}$ pint) milk, 15g ($\frac{1}{2}$oz) butter, salt and pepper in a bowl and beat thoroughly until smooth. 2. Beat 3 times during cooking until desirably set. 3. Leave to stand for 30 seconds before serving.

NOTES:

- Only serve food which is thoroughly cooked, use a professional food thermometer to ensure acceptable temperatures have been reached throughout.
- Hygiene - see Food Handling & Preparation, Page 10
- When cooking joints of meat small pieces of aluminium foil can be used to shield small areas of meat if they start to overcook.
- During standing time food should be covered. If covered during cooking, leave covered. If cooked uncovered, cover with foil.
- The cooking times given above are provided as a guide only. Cooking times will vary according to food weight, quality and initial temperature. Please ensure that food is thoroughly cooked before serving.

REHEATING CHART

FOOD	TEMP	QUANTITY	METHOD	REHEATING TIME ON HIGH (100%)
BREAKFAST				
Porridge	Chilled	125g (5oz)	Place in a bowl, uncovered	35 sec
Scrambled Egg	Chilled	125g (5oz)	Place on a plate, uncovered	30 sec
Scrambled Egg with bacon or sausage	Chilled	175g (6oz)	As above	50 sec
Bacon	Chilled	4 rashers	As above	25 sec
Sausages - thick	Chilled	4	As above	35 sec
Sausages - thin	Chilled	8	As above	35 sec
Smoked Haddock	Chilled	175g (6oz)	As above	45 sec
Mushrooms	Chilled	100g (4oz)	Place in a bowl, uncovered	15 sec
Fresh Tomatoes	Chilled	100g (4oz)	As above	15 sec
HOT SANDWICHES				
Hamburger	Chilled	125g (5oz)	Place on a plate, uncovered	35 sec
Chickenburger	Chilled	135g (5oz)	As above	35 sec
Cheeseburger	Chilled	175g (6oz)	As above	35 sec
Hot Dog	Chilled	175g (6oz)	As above	35 sec
Bacon	Chilled	175g (6oz)	As above	35 sec
Sausage	Chilled	225g (8oz)	As above	50 sec
Beef	Chilled	175g (6oz)	As above	35 sec
PREPARED DISHES				
Lasagne	Chilled	300g (11oz)	1. Place on a plate, cover with cling film 2. Stand covered for 2-3 minutes	2 mins 15 sec
Chilli con Carne & Rice	Chilled	325g (12oz)	As above	2 mins
Curry & Rice	Chilled	300g (11oz)	As above	2 mins
Shepherds Pie	Chilled	300g (11oz)	As above	1 min 15 sec
Stew & Dumplings	Chilled	400g (14oz)	As above	2 mins 30 sec
Bangers & Mash	Chilled	325g (12oz)	Place on a plate, cover with cling film	1 min 15 sec
Duck à l'orange	Chilled	540g (1lb 4oz)	As above	3 mins 15 sec

R

REHEATING CHART

FOOD	TEMP	QUANTITY	METHOD	REHEATING TIME ON HIGH (100%)
PREPARED DISHES				
Spaghetti Bolognese	Chilled	300g (11oz)	Place on a plate, cover with cling film	1 min 15 sec
Chicken in a sauce	Chilled	300g (11oz)	As above	2 mins 30 sec
Beef Stroganoff & Rice	Chilled	375g (13oz)	As above	2 mins 30 sec
BBQ Ribs	Chilled	375g (13oz)	As above	2 mins
Rice/Pasta	Chilled	225g (8oz)	As above	45 sec
SAVOURY BREAD AND PASTRY				
Dinner Roll(s)	Chilled	1	Place on the turntable, uncovered	5 sec
		2	As above	10 sec
Croissant(s)	Chilled	1	As above	4 sec
		2	As above	6 sec
Garlic Bread	Chilled	250g (9oz)	As above	20 sec
Pizza Slice	Chilled	125g (5oz)	Place on a plate, uncovered	25 sec
	Frozen	100g (4oz)	As above	50 sec
Pizza - small	Chilled	75g (3oz)	As above	15 sec
	Frozen	100g (4oz)	As above	50 sec
Pizza - large	Chilled	400g (14oz)	As above	1 min
	Frozen	400g (14oz)	As above	2 mins
Meat Pie - small	Chilled	125g (5oz)	1. Place on a plate, uncovered 2. Stand for 2-3 minutes	30 sec
Meat Pie - large	Chilled	450g (1lb)	1. Place on a plate, uncovered 2. Stand for 3-4 minutes	1 min 10 sec
Quiche - slice	Chilled	125g (5oz)	1. Place on a plate, uncovered 2. Stand for 2-3 minutes	30 sec
Quiche - whole	Chilled	540g (1lb 4oz)	1. Place on a plate, uncovered 2. Stand for 3-4 minutes	1 min 30 sec
Cornish Pastie(s) (175g)(6oz) each	Chilled	1	Place on a plate, uncovered	35 sec
		2	As above	1 min 10 sec
Sausage Roll(s) 75g (3oz) each	Chilled	1	Place on a plate, uncovered	15 sec
		2	As above	25 sec

REHEATING CHART

FOOD	TEMP	QUANTITY	METHOD	REHEATING TIME ON HIGH (100%)
CANNED FOODS				
Baked Beans	Room	450g (1lb)	Place in a bowl, cover with cling film, stir halfway through cooking	1 min 30 sec
Sausage & Beans	Room	450g (1lb)	As above	2 mins 10 sec
Soup - thick/thin	Room	425g (15oz)	As above	1 min 50 sec
Hot Dogs	Room	425g (15oz)	Place in a bowl, cover with cling film	1 min 45 sec
Peas	Room	550g (1lb 4oz)	Place in a bowl, cover with cling film, stir halfway through cooking	2 mins 10 sec
Sweetcorn	Room	325g (12oz)	As above	1 min 30 sec
Carrots - whole, sliced	Room	540g (1lb 4oz)	As above	2 mins 30 sec
Tomatoes	Room	400g (14oz)	As above	2 mins 30 sec
Asparagus	Room	350g (12oz)	As above	1 min 50 sec
Green Beans	Room	300g (11oz)	Place in a bowl, cover with cling film, stir halfway through cooking	2 mins 30 sec
FRESH VEGETABLES				
Green Beans	Chilled	125g (5oz)	Place on a plate, uncovered	30 sec
Broccoli	Chilled	125g (5oz)	Place on a plate, uncovered	30 sec
Carrots - sliced	Chilled	125g (5oz)	Place on a plate, uncovered	30 sec
Cauliflower	Chilled	125g (5oz)	Place on a plate, uncovered	30 sec
Corn on the Cob	Chilled	200g (7oz)	Place on a plate, uncovered	1 min 10 sec
Peas	Chilled	100g (4oz)	Place on a plate, uncovered	30 sec
Jacket Potatoes	Chilled	250g (9oz)	Place on the turntable, uncovered	1 min
New Potatoes	Chilled	225g (8oz)	Place on a plate, uncovered	1 min
Brussels Sprouts	Chilled	225g (8oz)	Place on a plate, uncovered	30 sec

R

EHEATING CHART

FOOD	TEMP	QUANTITY	METHOD	REHEATING TIME ON HIGH (100%)
MEAT PORTIONS				
Chicken Portions				
Leg	Chilled	1 (300g)(11oz)	Place on a plate, cover with cling film	1 min
Breast	Chilled	1 (400g)(14oz)	Place on a plate, cover with cling film	1 min 30 sec
Lamb Chops	Chilled	3 (225g)(8oz)	Place on a plate, cover with cling film	1 min 30 sec
Pork Chop	Chilled	1 (125g)(5oz)	Place on a plate, cover with cling film	50 sec
Sliced Meat with Gravy	Chilled	1 (225g)(8oz)	Place on a plate, cover with cling film	1 min 30 sec
Gammon-sliced	Chilled	1(250g)(9oz)	Place on a plate, cover with cling film	55 sec
Trout	Chilled	1(200g)(7oz)	Place on a plate, cover with cling film	1 min
Salmon Steak	Chilled	1(200g)(7oz)	Place on a plate, cover with cling film	1 min
SWEET PORTIONS				
Fruit Crumble	Chilled	175g (6oz)	Place in a bowl, uncovered	35 sec
Fruit Crumble with custard	Chilled	275g (10oz)	Place in a bowl, uncovered	1 min
Fruit Pie	Chilled	175g (6oz)	Place in a bowl, uncovered	35 sec
Fruit Pie with Custard	Chilled	275g (10oz)	Place in a bowl, uncovered	50 sec
Sponge Pudding	Chilled	125g (5oz)	Place in a bowl, uncovered	20 sec
Sponge Pudding with Custard	Chilled	225g (8oz)	Place in a bowl, uncovered	45 sec
Suet Pudding	Chilled	175g (6oz)	Place in a bowl, uncovered	20 sec
Suet Pudding with Custard	Chilled	275g (10oz)	Place in a bowl, uncovered	45 sec
Chocolate Fudge Cake	Chilled	125g (5oz)	Place on a plate, uncovered	15 sec

NOTES:

- Only serve food which is thoroughly reheated, use a professional food thermometer to ensure acceptable temperatures have been reached throughout.
- Temperatures referred to in this chart are: *Room*, approx. 20°C, *Chilled*, approx. 5°C, and *Frozen*, approx. -18°C
- Hygiene - see Food Handling & Preparation, Page 10
- During standing time (where recommended) food should be covered. If covered during reheating, leave covered. If reheated uncovered, cover with foil.
- The reheating times given above are provided as a guide only. Reheating times will vary according to food weight, quality and initial temperature. Please ensure that food is thoroughly reheated before serving.

C LEANING & MAINTENANCE

WARNING

• Do not allow grease or dirt to build up on the door seals and adjacent parts as this may prevent the door from closing correctly and may cause a leakage of microwaves. To clean use a mild detergent solution on a soft damp cloth.

- DO NOT OPERATE the oven without the splash cover in place.
- DO NOT REMOVE the splash cover UNLESS THE POWER CORD IS REMOVED FROM THE OUTLET because the rotary antenna, which is located on the ceiling, operates for 1 minute after the door is opened and injury could occur.
- Keep the ceramic floor clean at all times. If you leave grease or fat in the cavity, it may overheat, smoke or even catch fire when next using the oven.

- Never use spray cleaners, oven keys or abrasive scourers as these damage the surface of the oven.
- Do not remove the ceramic floor from the oven.
- Do not use commercial oven cleaners, abrasive or harsh cleaners or scouring pads on any part of your microwave oven.
- Do not sprinkle water onto the oven directly. It may cause electric shock, leakage of electricity or damage of the oven.
- Failure to maintain the oven in a clean condition could lead to deterioration of the surface that could adversely affect the life of the appliance and possibly result in a hazardous situation.

SPLASH COVER

AT LEAST ONCE A WEEK, REMOVE THE SPLASH COVER AND WASH BOTH SIDES OF IT IN A MILD DETERGENT SOLUTION. A BUILD UP OF GREASE MAY OVERHEAT AND BEGIN TO SMOKE AND MAY BURN THE SPLASH COVER. THE SPLASH COVER IS LOCATED IN THE TOP OF THE OVEN AND MAY EASILY BE REMOVED. REMEMBER TO UNPLUG THE POWER CORD.

Removal:

1. Remove two thumb screws (A) as shown in Fig. 1.
2. Remove the splash cover from the oven.

Reinstall:

1. Insert two projections of the cover (B) into the holes of the oven cavity backplate as shown in Fig. 2.
2. Secure the cover to the oven ceiling with two thumb screws (A) as shown in Fig. 1.

Fig. 1

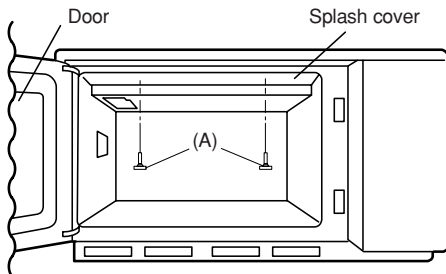
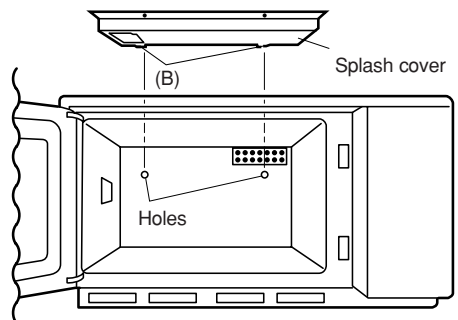

Fig. 2



OVEN LIGHT REPLACEMENT

Unplug the oven before removing the removable cover to access oven light bulb, and replace the light bulb (25W/240V). Make sure that the cover is secured to the oven cabinet after replacing the light bulb. See page 1.

OVEN INTERIOR

Clean the microwave oven cavity, at the end of each day with a damp soft cloth for hygienic reasons. For heavier soil, use mild soap applied with a soft damp cloth wipe clean ensuring all mild soap is removed. Make sure that mild soap or water does not penetrate through the small vents in the walls which may cause damage to the oven.

Take care not to let soapy water drip through the small holes in the oven walls. Excess water spillage through these holes will cause damage to the oven interior. It is important that the door seals and sealing surfaces are kept clean at all times, wipe regularly with a damp cloth. The ceramic floor should be kept clean at all times. Minor spills may be wiped with a damp cloth.

OUTER CABINET

Wipe the outside cabinet with a mild detergent solution on a soft cloth. The control panel must be wiped clean whilst the door is open, therefore inactivating the oven.

Keep the air intake filter clean. Clean the air intake filter once every two weeks.

Remove the air intake filter by pulling the two (2) clips on the sides of the filter.

Wash the air intake filter in mild soapy water, rinse and dry with a soft cloth.

After cleaning re-install the air intake filter.

Do not operate the oven without the air intake filter in place.

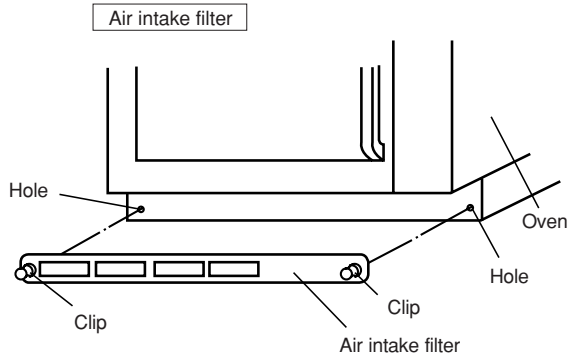

TROUBLESHOOTING

If you think the oven is not working properly there are some simple checks which you can carry out yourself before you call for an engineer. This will help prevent unnecessary service calls if the fault is something simple.

Simply answer "YES" or "NO" to the following questions:

1 Do the oven lamp and fan motor come on for 1 minute when you open the door? **YES/NO**

Put half a cup of water on the ceramic floor in the oven and close the door. Cook for 1 minute at 100%.

2 Does the oven lamp come on? **YES/NO**

3 Does the fan motor work? (Check by placing your hand above the air vent openings) **YES/NO**

4 After 1 minute does the "Beep" signal sound? **YES/NO**

5 And did the heating indicator "ON" go out?

YES/NO

6 Is the water in the cup hot? **YES/NO**

⚠ WARNINGS:

• **Never adjust, repair or modify the oven yourself, or allow anyone other than a Service Technician, appointed by SHARP to carry out the service.**

- The door seal stops microwave leakage during oven operation, but does not form an airtight seal. It is normal to see drops of water, light or feel warm air around the oven door. Food with a high moisture content will release steam and cause condensation inside the door which may drip from the oven.
- Repairs & Modifications: Do not attempt to operate the oven if it is not working properly.
- Outer Cabinet & Lamp Access: Never remove the outer cabinet. This would be very dangerous due to high voltage parts inside which must **never** be touched, as this could be fatal. As your oven has a removable cover over oven light bulb, it is possible for you to replace the light bulb yourself with care. To purchase the light bulb, please contact your supplier or our help desk. See page 25. Unplug the oven before replacing the light bulb.

PROBLEM	POSSIBLE CAUSE
Draught circulates around the door.	When oven is working, air circulates within the cavity. The door does not form an airtight seal so air may escape from the door.
Condensation forms in the oven, and may drip from the door.	The oven cavity will normally be colder than the food being cooked, and so steam produced when cooking will condense on the colder surface. The amount of steam produced depends on the water content of the food being cooked. Some foods, such as potatoes have a high moisture content. Condensation trapped in the door glass should clear after a few hours.
Flashing or arcing from within the cavity when cooking.	Arcing will occur when a metallic object comes into close proximity to the oven cavity during cooking. This may possibly roughen the surface of the cavity, but would not otherwise damage the oven.
Arcing potatoes.	Ensure all "eyes" are removed and place in a heat resistant flan dish or similar.
After setting the time, the oven does not start.	Check the door is closed properly.
Oven cooks too slowly.	Ensure correct power level has been selected.
Oven makes a noise.	The microwave energy pulses ON/OFF during cooking/defrosting.
Outer cabinet is hot.	The cabinet may become warm to the touch - keep children away

T

O REPLACE THE MAINS PLUG

The wires in the mains cable are colour coded as shown opposite:

As the colours of the cores in the mains lead of your oven may not correspond with the coloured marking identifying the terminals in your plug, connect the wires as shown: Make sure the terminal screws are tight and the cable is held securely by the cable grip where it enters the plug. Like most appliances in your home, your oven must be connected to a single phase 230-240 Volt, 50Hz alternating current supply.

If you do not make the proper electrical connections you might damage the oven or injure yourself. Neither SHARP nor the supplier will be liable if this happens.

green and yellow stripes = **EARTH**
blue = **NEUTRAL**
brown = **LIVE**

- The green and yellow wire to the plug terminal marked E or \perp or coloured green or coloured green and yellow.
- The blue wire to the plug terminal marked N or coloured black or coloured blue.
- The brown wire to the plug terminal marked L or coloured red or coloured brown.

 **WARNING:**

**THIS APPLIANCE MUST BE EARTHED.
IF YOU HAVE ANY DOUBTS ABOUT YOUR
ELECTRICAL SUPPLY ASK A QUALIFIED
ELECTRICIAN.**

C

ALLING FOR SERVICE

- If you are unable to resolve a problem using the checks covered on the last few pages, do not attempt to service this microwave oven yourself.
- Contact the dealer or supplier from whom the oven was purchased in order to obtain service.
01296 663400 (office hours)
- For general information & assistance with oven queries, please contact our help desk:
Telephone: 01296 663400 (office hours)
e-mail: customerservice@rhhall.com

SPECIFICATIONS:

	R-23AM
AC Line voltage	Single phase 230-240V, 50Hz
AC Power required	2.9kW
Output power	1900W (IEC 60705)
Microwave frequency	2450MHz* (Group 2 / Class B)
Sound level	less than 70dB(A)
Outside dimensions	510(W) x 335(H) x 470(D) mm (Single) 510(W) x 670(H) x 470(D) mm (Two ovens stacked)
Cavity dimensions	330(W) x 180(H) x 330(D) mm
Oven capacity	0.7 cu.ft (20 litres)
Cooking uniformity	Rotary antenna system
Weight	Approx. 33kg

* This Product fulfils the requirement of the European standard EN55011. In conformity with this standard, this product is classified as group 2 class B equipment. Group 2 means that the equipment intentionally generates radio-frequency energy in the form of electromagnetic radiation for heating treatment of food. Class B equipment means that the equipment suitable to be used in domestic establishments.

(This product is designed for commercial application only and as such it falls outside the scope of Regulation (EC) 1275/2008 implementing EU Directive 2005/32/EC on eco-design requirements for standby and off mode electric power consumption. Sharp do not recommend the product for domestic application and will not accept any liability for such use.)

- As part of a policy of continuous improvement, we reserve the right to alter design and specification without notice.

NOTE: External Equipotential Earthing Terminal

Equipment has secondary earthing terminal.

Terminal provides external earthing connection used in addition to earthing prong on plug. Located on outside of oven back, terminal is marked with symbol shown on the right side.



Information on the Disposal of this Equipment



IF YOU WISH TO DISPOSE OF THIS EQUIPMENT, DO NOT USE THE ORDINARY WASTE BIN, AND DO NOT PUT THEM INTO A FIREPLACE!

Used electrical and electronic equipment should always be collected and treated SEPARATELY in accordance with local law.

Separate collection promotes an environment-friendly treatment, recycling of materials, and minimizing final disposal of waste. IMPROPER DISPOSAL can be harmful to human health and the environment due to certain substances! Take USED EQUIPMENT to a local, usually municipal, collection facility, where available.

If in doubt about disposal, contact your local authorities or dealer and ask for the correct method of disposal.

ONLY FOR USERS IN THE EUROPEAN UNION, AND SOME OTHER COUNTRIES; FOR INSTANCE NORWAY AND SWITZERLAND: Your participation in separate collection is requested by law.

The symbol shown above appears on electrical and electronic equipment (or the packaging) to remind the users of this.

Users from PRIVATE HOUSEHOLDS are requested to use existing return facilities for used equipment. Return is free of charge.

If the equipment has been used for BUSINESS PURPOSES, please contact your SHARP dealer who will inform you about take-back. You might be charged for the costs arising from take-back. Small equipment (and small quantities) might be taken back by your local collection facility. For Spain: Please contact the established collection system or your local authority for take-back of your used products.

Manufacturer:

SHARP Corporation

1 Takumi-cho, Sakai-ku, Sakai-shi, Osaka 590-8522, Japan

Authorised Representative:

SHARP Electronics Europe Ltd.

4 Furzeground Way, Stockley Park, Uxbridge, Middlesex, UB11 1EZ, UK

SHARP Electronics GmbH

Nagelsweg 33-35, 20097 Hamburg, Germany



TINSEB420WRRZ-K11