



Built-in

2022

Built-In Refrigerators
Built-In Ovens
Built-In Hobs
Built-In Oven-Hob Poly Sets
Hoods
Built-In Dishwashers
Built-in Washing Machines

SHARP

Be Original.





Index	3
Built-in Refrigerators	
Premium Features	6
Features	8
Line-up	14
Built-in Ovens	
Premium Features	30
Aesthetics	46
Line-up	50
Built-in Hobs	
Premium Features	82
Line-up	88
Oven-Hob Poly Sets	
Line-up	114
Hoods	
Line-up	121
Built-in Dishwashers	
Premium Features	133
Features	136
Basket Options	145
Line-up	147
Washing Machines	
Premium Features	162
Features	164
Line-up	169





Built-in Refrigerators

Premium Features

summary



AdvancedNoFrost

Independent circulation systems for freezer and fridge preventing frost and odour mixing



GentleAirFlow

Advanced air distribution control helps prevent food from drying



OptiMoist

Allows adjustment of humidity levels to help preserve fruit and vegetables



Fruit&Veg Zone

Ideal for storing fruit and vegetables keeping them fresh and crisp



ZeroDegree Zone

Creates the optimum conditions for storing fresh meat and fish for longer



OdourNeutral

Independent circulation systems for freezer and fridge preventing frost and odour mixing



AdaptiLift

Easily adjust the position of the door trays to suit your needs



AdaptiShelf

Adjust the shelf of your fridge easily to use space efficiently



SpaceSaverDoor

The fridge can go right up the wall, no additional space needed



Dual Control

Electronic control where you can adjust the temperature of your fridge and freezer compartments independently. Consumer can control the fridge and freezer compartments separately



AdaptiFreezer

Our technology ensures your freezer will always keep working whatever the outside temperature - even if it drops as low as -15°C



NanoFrost

More efficient cooling performance, through reducing the need to defrost. Resulting in greater storage capacity



TwinLED

Brighter compartment and better food visibility



AntiFingerprint

Helps prevent fingerprints, keeping your fridge looking shiny and new



GlassDoor

The attractive glass design fits perfectly in today's modern kitchen. The high-quality, safety glass fronts are treated to be super tough

Longer Freshness



AdvancedNoFrost



OdourNeutral

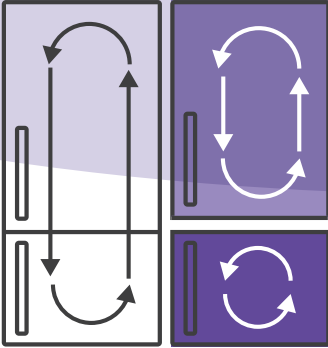

Two independent and dedicated cooling systems maximizes cooling and freezing results, ensuring frost free compartments whilst also stopping any mixing of odors.



GentleAirFlow

Maintains the fresh texture and taste of food by preventing any humidity loss in the fridge compartment.





ZeroDegree Zone

Creates the optimum conditions for storing fresh meat and fish for longer.



Fruit&Veg Zone

Ideal for storing fruit and vegetables keeping them fresh and crisp.



E-filter technology helps to remove ethylene gas (a bioproduct released naturally from fresh foods) and unpleasant odors from the crisper. In this way, food stays fresh for a longer time.



Longer Freshness



AdaptiFresh



AdaptiMoist



OptiMoist



Humidity Control Technologies

With the humidity control technologies, adjustment of humidity levels to help preserve fruit and vegetables.

 Only Vegetable Mode

 Fruit and Vegetable Mode

 Only Fruit Mode

Flexibility



NanoFrost

Thanks to the usage of wrap around evaporator;

- ✓ More Efficient Cooling.
- ✓ Less Manual Defrost Requirement.
- ✓ Higher and More Flexible Storage Capacity.



Water Dispenser

Continuously 2l liters chilled water availability and hygienic use thanks to removable tank.



AdaptiFreezer

AdaptiFreezer is even if at super low (-15°C) ambient temperatures, freezer section of the refrigerator maintain working to keep the frozen foods frozen. (-18°C)



Dual Control

Temperature of the freezer and fridge compartments can be adjusted independently.



Flexibility



AdaptiLift

Adjust the height of the door racks to create more space for larger items. Easy to change height even it's loaded.



AdaptiShelf

Slide and hide half the shelf to create more space for large and extremely sized items. Easy in managing space in fridge compartment.

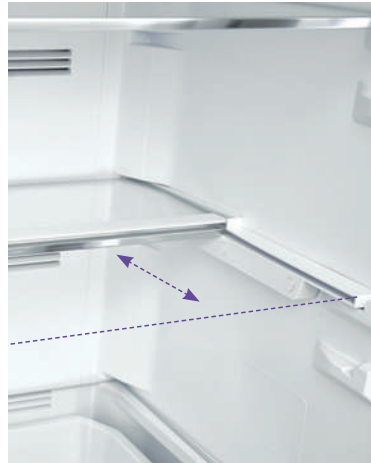



SpaceSaverDoor

For conventional door mechanism, additional space for opened door is required. But, thanks to space saver door, the fridges can go right up the wall, no additional space needed.



AntiFingerPrint

High Quality door material, helps prevents fingermarks, keeping your fridge looking shiny and new.
(Only applicable for inox models)



TwinLED

Brighter compartment and better food visibility. Both sides installed LED evenly to light interior



GlassDoor

Pretty glass door design, with stylish appearance and more resistance against scratches compared to metal sheet.





Built-in Models *Direct Cooling*

54x88cm Models

54x122cm Models

54x144cm Models

SJ-LF123M1X

SJ-LE123M0X

SJ-LE123M1X



<i>Energy Class</i>	F / E
<i>Volume Total(net) (lt)</i>	121
<i>Volume Refrigerator Total (net) (lt)</i>	104
<i>Volume Freezer(net) (lt)</i>	17
<i>Noise Emission dB(A)</i>	38
<i>Product dimensions (WxDxH) (mm)</i>	540X545X875
<i>Cooling Type</i>	Direct Cooling
<i>Wine Rack</i>	N/A
<i>Adapti Lift</i>	N/A
<i>Adapti Shelf</i>	N/A
<i>Odour Free</i>	N/A
<i>GentleAirFlow</i>	N/A
<i>Humidity Control Technology</i>	N/A
<i>Zero Degree Zone</i>	N/A

** AntiFingerPrint Feature is only available with stainless steel material.*

SJ-SF099M1X

SJ-SE099M0X



<i>Energy Class</i>	F / E
<i>Volume Total(net) (lt)</i>	95
<i>Volume Refrigerator Total (net) (lt)</i>	-
<i>Volume Freezer(net) (lt)</i>	95
<i>Noise Emission dB(A)</i>	38
<i>Product dimensions (WxDxH) (mm)</i>	540X545X875
<i>Cooling Type</i>	Direct Cooling
<i>Wine Rack</i>	N/A
<i>Adapti Lift</i>	N/A
<i>Adapti Shelf</i>	N/A
<i>Odour Free</i>	N/A
<i>GentleAirFlow</i>	N/A
<i>Humidity Control Technology</i>	N/A
<i>Zero Degree Zone</i>	N/A

** AntiFingerPrint Feature is only available with stainless steel material.*

SJ-LF134M1X

SJ-LE134M1X

SJ-LE134M0X



<i>Energy Class</i>	F / E
<i>Volume Total(net) (lt)</i>	134
<i>Volume Refrigerator Total (net) (lt)</i>	134
<i>Volume Freezer(net) (lt)</i>	-
<i>Noise Emission dB(A)</i>	38
<i>Product dimensions (WxDxH) (mm)</i>	540X545X875
<i>Cooling Type</i>	Direct Cooling
<i>Wine Rack</i>	N/A
<i>Adapti Lift</i>	N/A
<i>Adapti Shelf</i>	N/A
<i>Odour Free</i>	N/A
<i>GentleAirFlow</i>	N/A
<i>Humidity Control Technology</i>	N/A
<i>Zero Degree Zone</i>	N/A

** AntiFingerPrint Feature is only available with stainless steel material.*

SJ-LF160M1X

SJ-LE160M0X



<i>Energy Class</i>	F / E
<i>Volume Total(net) (lt)</i>	160
<i>Volume Refrigerator Total (net) (lt)</i>	160
<i>Volume Freezer(net) (lt)</i>	-
<i>Noise Emission dB(A)</i>	38
<i>Product dimensions (WxDxH) (mm)</i>	540x545x1020
<i>Cooling Type</i>	Direct Cooling
<i>Wine Rack</i>	N/A
<i>Adapti Lift</i>	N/A
<i>Adapti Shelf</i>	N/A
<i>Odour Free</i>	N/A
<i>GentleAirFlow</i>	N/A
<i>Humidity Control Technology</i>	N/A
<i>Zero Degree Zone</i>	N/A

** AntiFingerPrint Feature is only available with stainless steel material.*

SJ-LF204M1X

SJ-LE204M0X



Energy Class	F / E
Volume Total(net) (lt)	200
Volume Refrigerator Total (net) (lt)	200
Volume Freezer(net) (lt)	-
Noise Emission dB(A)	38
Product dimensions (WxDxH) (mm)	540X545X1225
Cooling Type	Direct Cooling
Wine Rack	Wine Rack
Adapti Lift	N/A
Adapti Shelf	N/A
Odour Free	N/A
GentleAirFlow	N/A
Humidity Control Technology	N/A
Zero Degree Zone	N/A

** AntiFingerPrint Feature is only available with stainless steel material.*

SJ-TF214M1X

SJ-TE214M0X

SJ-TE214M1X



<i>Energy Class</i>	F / E
<i>Volume Total(net) (lt)</i>	210
<i>Volume Refrigerator Total (net) (lt)</i>	172
<i>Volume Freezer(net) (lt)</i>	38
<i>Noise Emission dB(A)</i>	39
<i>Product dimensions (WxDxH) (mm)</i>	540X545X1445
<i>Cooling Type</i>	Direct Cooling
<i>Wine Rack</i>	Wine Rack
<i>Adapti Lift</i>	N/A
<i>Adapti Shelf</i>	N/A
<i>Odour Free</i>	N/A
<i>GentleAirFlow</i>	N/A
<i>Humidity Control Technology</i>	N/A
<i>Zero Degree Zone</i>	N/A

** AntiFingerPrint Feature is only available with stainless steel material.*

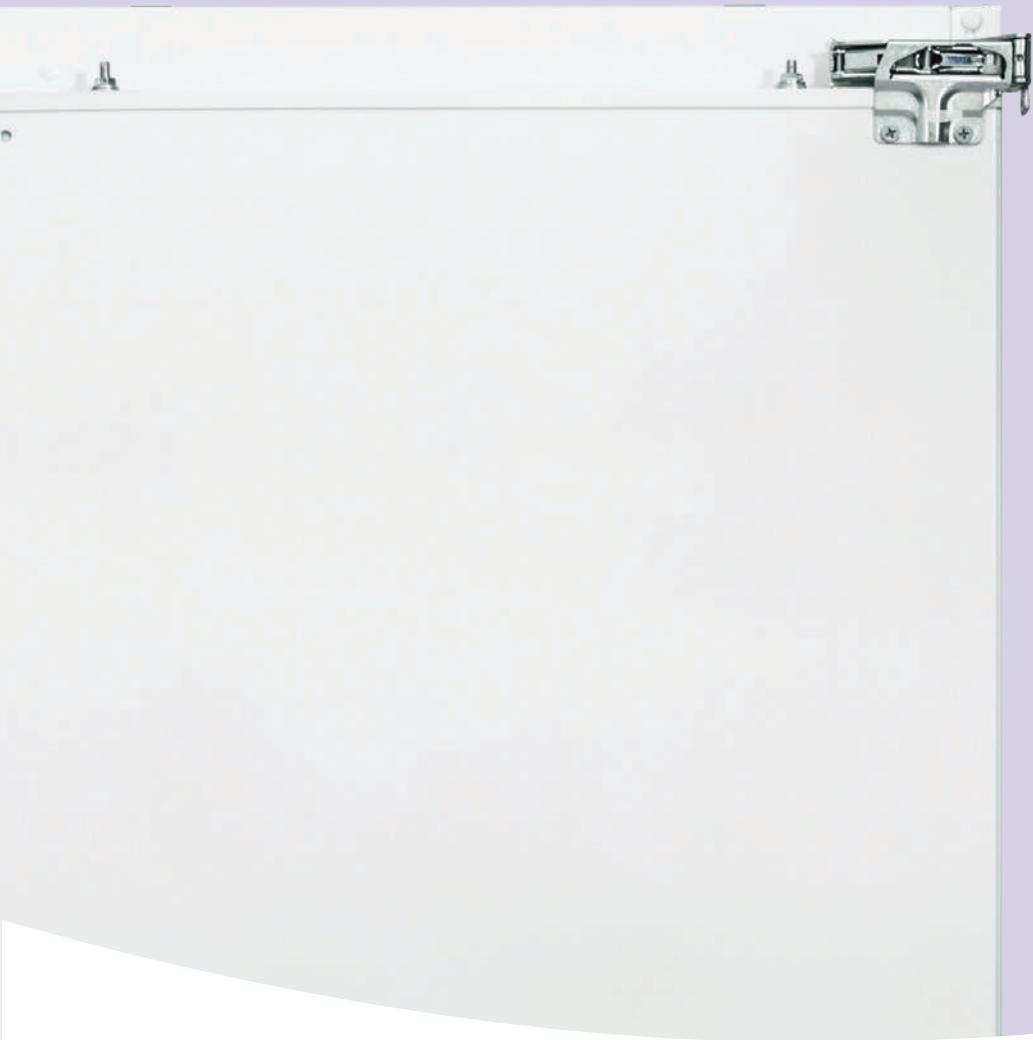

Built-in Models *No Frost & Direct Cooling*

54x177cm Bottom Freezers

54x177cm Single Door Freezers

54x177cm Single Door Larders

SJ-BF227M01X

SJ-BF227M00X

SJ-BE227M00X



Energy Class	F / E
Volume Total(net) (lt)	230
Volume Refrigerator Total (net) (lt)	145
Volume Freezer(net) (lt)	85
Noise Emission dB(A)	41
Product dimensions (WxDxH) (mm)	540X545X1770
Cooling Type	No frost
Wine Rack	Wine Rack
Adapti Lift	AdaptiLift
Adapti Shelf	N/A
Odour Free	N/A
GentleAirFlow	GentleAirFlow
Humidity Control Technology	AdaptiFresh
Zero Degree Zone	N/A



* AntiFingerPrint Feature is only available with stainless steel material.

SJ-BF243M01X

SJ-BE243M00X



Energy Class	F / E
Volume Total(net) (lt)	229
Volume Refrigerator Total (net) (lt)	181
Volume Freezer(net) (lt)	68
Noise Emission dB(A)	38
Product dimensions (WxDxH) (mm)	540X545X1770
Cooling Type	Static
Wine Rack	Wine Rack
Adapti Lift	AdaptiLift
Adapti Shelf	N/A
Odour Free	N/A
GentleAirFlow	N/A
Humidity Control Technology	AdaptiFresh
Zero Degree Zone	N/A



* AntiFingerPrint Feature is only available with stainless steel material.



SJ-BF237M01X

SJ-BE237E00X

SJ-BF237M00X

SJ-BE237M01X

Energy Class	F / E
Volume Total(net) (lt)	243
Volume Refrigerator Total (net) (lt)	180
Volume Freezer(net) (lt)	63
Noise Emission dB(A)	41
Product dimensions (WxDxH) (mm)	540X545X1770
Cooling Type	No frost
Wine Rack	Wine Rack
Adapti Lift	AdaptiLift
Adapti Shelf	N/A
Odour Free	Odour Free
GentleAirFlow	GentleAirFlow
Humidity Control Technology	AdaptiFresh
Zero Degree Zone	N/A



* AntiFingerPrint Feature is only available with stainless steel material.



SJ-SF197E01X

SJ-SE197E00X

SJ-SE197E01X

Energy Class	F / E
Volume Total(net) (lt)	197
Volume Refrigerator Total (net) (lt)	-
Volume Freezer(net) (lt)	197
Noise Emission dB(A)	40
Product dimensions (WxDxH) (mm)	540X545X1770
Cooling Type	No frost
Wine Rack	N/A
Adapti Lift	N/A
Adapti Shelf	N/A
Odour Free	N/A
GentleAirFlow	N/A
Humidity Control Technology	N/A
Zero Degree Zone	N/A



* AntiFingerPrint Feature is only available with stainless steel material.



SJ-LF300E01X

SJ-LE300E00X

SJ-LE300E01X

Energy Class	F / E
Volume Total(net) (lt)	294
Volume Refrigerator Total (net) (lt)	294
Volume Freezer(net) (lt)	-
Noise Emission dB(A)	39
Product dimensions (WxDxH) (mm)	540X545X1770
Cooling Type	Direct Cooling
Wine Rack	Wine Rack
Adapti Lift	AdaptiLift
Adapti Shelf	N/A
Odour Free	N/A
GentleAirFlow	N/A
Humidity Control Technology	AdaptiFresh
Zero Degree Zone	N/A



* AntiFingerPrint Feature is only available with stainless steel material.



Built-in Cookers



Sharp has won 23 awards from one of the most prestigious design and innovation awards, Plus X Awards 2021 in

«**Small and Large Home Appliances**» category with **6 products** of 2K20 Family Design Series.

Right along with 23 awards, Sharp has been awarded as the

«**Most Innovative Brand**» the top award of Plus X Award.

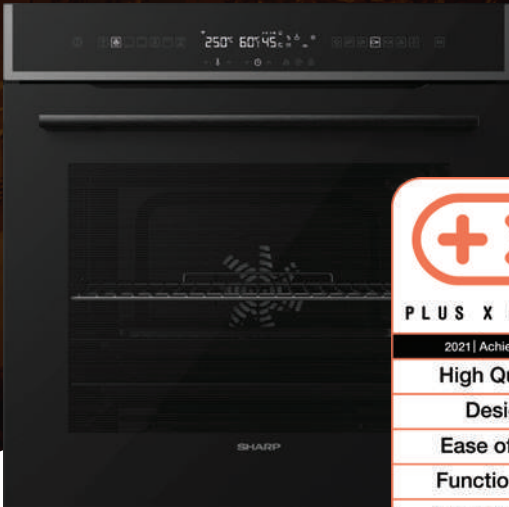



Built-in Ovens

Series I - II

Premium Features

Summary



EasyToClean Enamel

The smooth enamel interior helps make cleaning your oven easier



Catalytic Cleaning

It is easy to clean and time saving: the catalytic liners work when the oven is heated to 220°C and residue is oxidised



Pyrolytic Cleaning

Our Pyrolytic ovens mean no more scrubbing, keeping your oven sparkling clean. Self-cleaning process is set at 480°C that turns all residue to ash which can be easily removable from the oven



ActiveCool

ActiveCool technology keeps the door temperature safe even when self-cleaning. The 4 glass panel door ensures the outside surface remains cool, even at pyrolytic temperatures (480°C)



VapClean

By softening the oven dirt with steam, the VapClean function helps take the effort out of cleaning, gently steaming the inside of your oven



AirCurtain

When oven door is opened during cooking, it creates an air stream between control panel and oven bottom panel.



Remove&Wash

Taking the hassle out of keeping your oven clean, our removable inner glass oven door makes it incredibly easy to wash even in a dishwasher



Family Size Cavity

The bigger the better. The large cavity makes it suitable to cook for a large family



150 Autocooking Programs

Created by pro-chefs, 150 built in programs create the ultimate oven to dish experience. We have created this to make your life easier; simply press a program and let the oven do the rest: set time, temperature, and oven function



50 Autocooking Programs

Created by pro-chefs, 50 built in programs create the ultimate oven to dish experience. We have created this to make your life easier; simply press a program and let the oven do the rest: set time, temperature, and oven function



Love2Cook

While containing 150 autocooking programs, colourful 4.3" knob control TFT LCD display with Wi-Fi connectivity enabling remote control and capable of working with Innit



RoastPro Meat Probe

perfection temperature of your meat and make sure it is cooked to you like. Simply by using the sensor you can control the core
The ultimate cooking control gets your meat just the way



AirStream

There are 2 function fans in the oven cavity which operate to create hot air stream and distribute the heat evenly through the cavity.



RoastPro Turnspit

RoastPro Turnspit for all round cooking perfection. It delivers perfectly cooked whole chicken every single time



SuperQuiet

A special cooking function running at a 35 dB noise level.



Power Boost

Getting your food off to a flying start. It reduces the preheating duration by 50%, helping you to save time and energy



Telescopic Rails

Enables you to take heavy trays out safely and effortlessly from the hot oven



DoorSwitch

It provides better vision by turning lighting on when the oven door is open and energy saving by turning off lighting when it is closed and inactive



SteamAssistedCooking

Manual or auto-added moisture pouring water/steam from push&pull water tank elevating the cooking experience to another level



VapClean Plus

By softening the oven dirt with steam, the VapClean Plus function helps take the effort out of cleaning, gently steaming the inside of your oven



SoftClosingDoor

The oven door closes by itself gently and quietly thanks to a special hinge



EasyToClean Enamel



EasyToClean Enamel: the oven cavity is covered with a smooth and strong enamel.



Pyrolytic Cleaning



Pyrolytic Cleaning: the oven runs for 1,5 hours at 480°C to turn all residue to ash.



Catalytic Cleaning



Catalytic Cleaning: the catalytic liners work when the oven is heated to 220°C and residue is oxidized.



VapClean Plus

Steam cleaning programme to soften the oven dirt. The oven generates steam with water from the tank.



VapClean



VapClean: the oven runs at 90-100°C for 20 minutes while there is water boiling in a tray to soften the oven dirt.



ActiveCool

The 4 glass panel door and a forced cooling system ensure the outer surface remains cool, even at pyrolytic temperatures (480°C).



Remove&Wash

Remove&Wash: It allows you to remove and wash the inner oven door glass.





Family Size Cavity



Suitable for big families where 78lt cavity enables cooking bigger portions or several different dishes at different levels.



SoftClosingDoor



The oven door is closed slowly by itself thanks to a special hinge, when it is released just before closed position.



Telescopic Rails



Standard Telescopic Rails

Lets the $\frac{3}{4}$ of the tray pulled out.



Full Telescopic Rails

Lets the tray completely pulled out.



Love2Cook



- 4.3" colourful touch control TFT LCD display
- Wi-Fi Connected Smart Oven
- Remote Control
- Capable of working with Innit
- 150 Autocooking Programs
- Time clock and date
- 5 levels of display brightness
- 3 levels of buzzer tone
- 11 language options



Autocooking Programs



Created by pro-chefs, depending on the control panel, from 12 to 50 and 150 autocooking programs were created for the ultimate oven to dish experience.

Select your dish between many types of food (meat, fish, bread, cakes...) and let the oven do the rest automatically: set the appropriate duration, temperature and oven function.

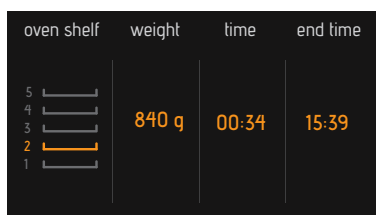



RoastPro Meat Probe

RoastPro Meat Probe: cooking stops automatically when the desired core temperature is reached.



PowerBoost

When the boost function is activated, it reduces the preheating duration by 50%.



DoorSwitch



Oven light is on/off by the help of a mechanical-electrical switch triggered by oven door opening/closing.

It also controls the remote control of the smart built-in ovens.



AirStream Technology

Two Fan Structure There are 2 function fans in the oven cavity which operate to create hot air stream and distribute the heat evenly through the cavity.

Cavity with air canals Thanks to these canals/ holes on the sides of the cavity a horizontal air stream is created.



AirCurtain Technology



When oven door is opened during cooking, oven creates an airflow from control panel to the oven bottom panel, preventing the hot air to reach face of the user.



SteamAddedCooking

Manual or auto-added moisture pouring water/steam from push&pull water tank elevating the cooking experience to another level.

Premium Pyrolytic Control Panels

Full Touch Pyro Timer



Pyrolytic cleaning with two levels for 1:00 hour and 1:30 hours can be used.

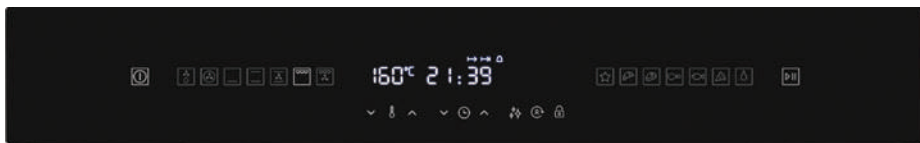

Pyrolytic cleaning with three levels for 1:00 hour, 1:15 hours and 1:30 hours can be used.

SteamBase Oven



Key Features

- ✓ 65L & 75L oven cavity,
- ✓ A special enamel coating for this feature,
- ✓ Easily activated with touch steam icon on the oven knob.
- ✓ Can be applied to pyrolytic self-cleaning ovens.
- ✓ Available with all control panels.

- 1 Pour the water into the chamber
- 2 Select any function with Steam Icon



SteamBase+ Oven



Key Features

- ✓ 65L & 75L oven cavities,
- ✓ Available with FD Digital and FD Visio Touch control panel
- ✓ A special enamel coating for this feature,
- ✓ Easily activated with touch steam icon on the oven control panel.
- ✓ Control the waterflow's timing and amount whenever you want to!

- 1 Pour the water inside the water tank
- 3 Water to reach to bottom of the cavity

- 2 Activate the steam icon by touching

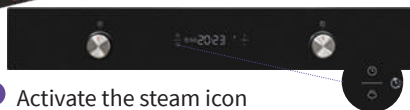



Sharp launches a groundbreaking, multifunctional smart oven series that is set to work with world-first cooking platform, Innit.

Be inspired and get creative in the kitchen with an Sharp's Love2Cook KS-76S50 Smart Oven, which can bring out the chef in you, whatever your cooking ability. Promising to shake up dinner routines, and raise the bar for home cooking.

Cook Smart.

Innit sends preset cooking instructions straight to your Sharp Smart Built-in Oven. Get the cooking guidance you need whether you are an amateur or aspiring chef. Step-by-step videos and easy how-tos help you go from inspiration to cooking with confidence.

Connect.

Effortlessly connect your Sharp Smart Built-In Oven to Innit via Sharp Home Application. After establishing the Wi-Fi connection between your smart oven and the application, you can easily use the remote control feature to have remarkable cooking experiences.

Get Inspired.

Get meal recommendations by creating your Food Profile according to your likes, dislikes, health or allergy concerns and cook times customized for your Sharp Smart Built-in Oven.



SHARP

Home

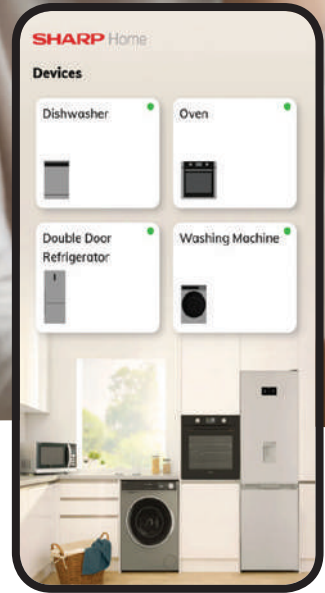

Sharp Home App

Thanks to Sharp Home App, it is now much easier to do daily routine tasks! You can control and monitor the devices and use smart functions. Sharp connected products and Sharp Home app are working together to make life more comfortable.

Remote Control: Sharp Home App connects you to the Sharp products. You can manage

and monitor your smart devices easily anytime from wherever you are.

Notifications: The app sends notifications to you about the program status and device/usage errors. For instance, “The cooking program finished” information invites you to enjoy your meal, and the “The refrigerator door is open” message reminds you to close



Please check the WiFi icon for smart availability for each product.



the door in order to minimize energy losses.
Delay Timer: It helps you to plan your daily routines. The devices will work according to your pre-arranged settings. Set the time and let the app manage the devices.

Recipes: You can discover various recipes from local to fusion cuisine.

Demo Mode: Even if you don't have a Sharp

product, you can still experience Sharp Home App through demo mode. Try and see how the app is designed helpfully!

Visit sharphomeapp.com for more information.

Aesthetic Accessories

Series I

Knobs



Orbis

Series II

Knobs



Onis (PIPO)



Luna



Apex (Mushroom)



Signum

Series I

Handles



Juno



Titan

Series II

Handles



Basic Margo Handle



Metal Margo Handle















Black Margo Handle

Control Panel Designs

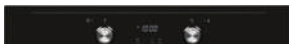
Series I

Control Panels

	Colour TFT Timer			High Smart Ovens
High	Monochrome TFT Timer			High High+ Oven
	Full LED Touch+			High Ovens
	Visio Touch+ Timer			High Ovens
	Visio Touch+ Timer			Mid Pyro 2 Ovens
Mid	Digital Timer			Mid Pyro 1 Ovens
	Touch Timer			Mid Ovens
Entry	Mechanical Timer			Entry Ovens

Series II Control Panels

FD Digital Touch Timer

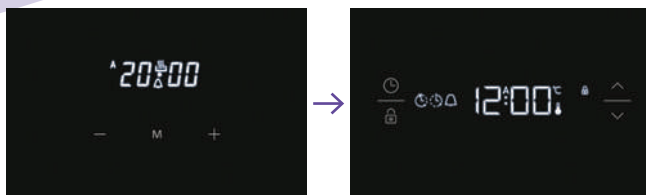

Series I Design

Series II Design

FD Visio Touch Timer

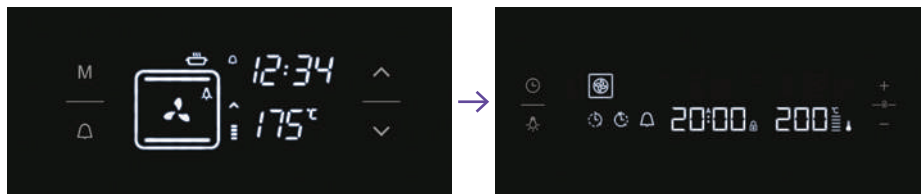

Series I Design

Series II Design

Slim LED Touch Control Panel



09:40

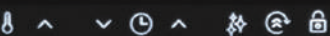

Built-in Ovens

Series II

KS-76S50BNP

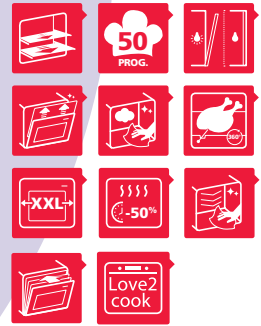

Volume & Cleaning Type: 78lt, Catalytic Cleaning & VapClean

Energy Class: A

Control Panel: Love2Cook TFT Timer

Feature: Wi-Fi Connected & Works with Innit

Handle: Black Margo Handle

Door: Full Inner Glass Door with Plastic Profiles & Removable Inner Glass & SoftClosingDoor

Oven Light: Top + Sides

Rack Type: Wire rack + 1 set of EasyFix Full Telescopic Rails

Other Features: DoorSwitch + PowerBoost

Trays: 1 shallow tray, 1 deep tray, 1 small tray

10 functions:

Ovenlight , Defrost , Fan+Ring , Top+Bottom, Top+Bottom+Fan , Pizza , Grill+Turnspit , DoubleGrill + Turnspit , DoubleGrill+Fan+Turnspit , VapClean



K-71L66BNH

Pyrolytic Cleaning LED Slim Touch Control Panel



Volume & Cleaning Type: 78lt, Pyrolytic

Cooling Type: ActiveCool technology

Energy Class: A

Cleaning Features: 3 level pyrolytic cleaning

Control Panel: LED Slim Touch

Oven Type: Multifunctional Oven

Oven Light: Top

Rack Type: Wire rack + 1 set of standard telescopic rails

Door: Removable Inner Glass + SoftClosingDoor

Trays: 1 shallow tray, 1 deep tray

8 functions:

Defrost, Fan+Ring, Bottom, Top+Bottom, Top+Bottom+Fan, Pizza, Double Grill, Double Grill+ Fan, Pyrolysis

K-71Z68BNM

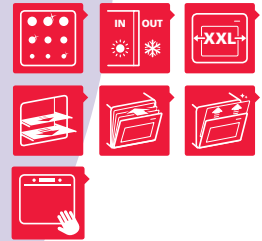

Volume & Cleaning Type: 78lt, Pyrolytic

Cooling Feature: ActiveCool Technology

Energy Class: A

Colour: Black

Control Panel: FD Visio Touch Timer

Knob: Onis (PIPO)

Handle: Basic Margo Handle

Oven Type: Multifunctional Oven

Oven Light: Top

Rack Type: Wire rack + 1 set of EasyFix full telescopic rails

Door: Removable Inner Glass + SoftClosingDoor

Trays: 1 shallow tray, 1 deep tray

10 functions:

Defrost , Turbo , Bottom, Top + Bottom, Top + Bottom + Fan, Pizza, Grill , Grill + Fan, 3D, Pyrolysis

K-61P27BNM



Volume & Cleaning Type: 68lt, Pyrolytic

Cooling Feature: ActiveCool Technology

Oven Type: Fan Assisted Oven

Energy Class: A

Colour: Black

Control Panel: FD Digital Touch Timer

Knob: Onis (PIPO)

Handle: Basic Margo Handle

Oven Light: Top

Rack Type: Wire rack + Removable Inner Glass

Trays: 1 shallow tray, 1 deep tray

6 functions:

Defrost, Top+Bottom, Top+Bottom+Fan, Grill, Double Grill, Pyrolysis

KA-75L64BNH

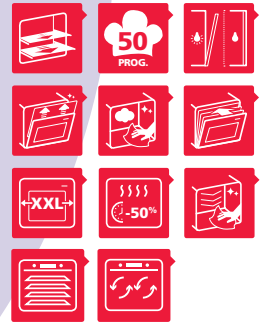

Volume & Cleaning Type: 73lt, Catalytic Cleaning & VapClean

Features: AirStream & AirCurtain & PowerBoost & 11 Autocooking Programs

Energy Class: A

Control Panel: LED Slim Touch Timer

Oven Type: Multifunctional Oven

Oven Light: Top

Rack Type: Wire Rack + 1 set of EasyFix Full Telescopic Rails

Door: Removable Inner Glass & Soft Closing Door & CoolTouch + DoorSwitch

Trays: 2 shallow tray, 1 deep tray , 1 small tray

9 functions:

Defrost, Fan+Ring, Bottom, Top+Bottom, Top+Bottom+Fan, Pizza, Double Grill, Double Grill+ Fan, VapClean

KA-70T50BNH

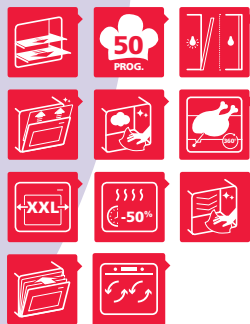

Volume & Cleaning Type: 78lt, Catalytic Cleaning & VapClean

Feature: AirCurtain + PowerBoost

Energy Class: A

Control Panel: Black Monochrome TFT Timer

Handle: Black Margo Handle

Door: Full Inner Glass Door with Plastic Profiles & Removable Inner Glass & SoftClosingDoor

Oven Light: (Top + Sides) + DoorSwitch

Rack Type: Wire rack + 1 set of EasyFix Full Telescopic Rails

Trays: 1 shallow tray, 1 deep tray , 1 small tray

10 functions:

Ovenlight, Defrost, Fan+Ring, Top+Bottom, Top+Bottom+Fan, Pizza, Grill+Turnspit, Double Grill+Turnspit, Double Grill+Fan+Turnspit, VapClean

KA-70Z68BNM

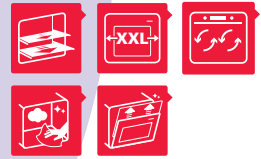

Volume & Cleaning Type: 78lt, Catalytic Cleaning & VapClean

Feature: AirCurtain

Energy Class: A

Colour: Black

Control Panel: FD Visio Touch Timer

Knob: Apex (Mushroom)

Handle: Metal Margo Handle

Door: Full Inner Glass Door with Plastic Profiles + Removable Inner Glass

Oven Type: Multifunctional Oven (Fan + Ring)

Oven Light: Top

Rack Type: Wire rack + 1 set of EasyFix Standard Telescopic Rails

Trays: 1 shallow tray, 1 deep tray, 1 small tray

10 functions:

Defrost , Turbo , Bottom, Top + Bottom, Top + Bottom + Fan, Pizza, Grill , Grill + Fan, 3D, VapClean

K-60P19BNM

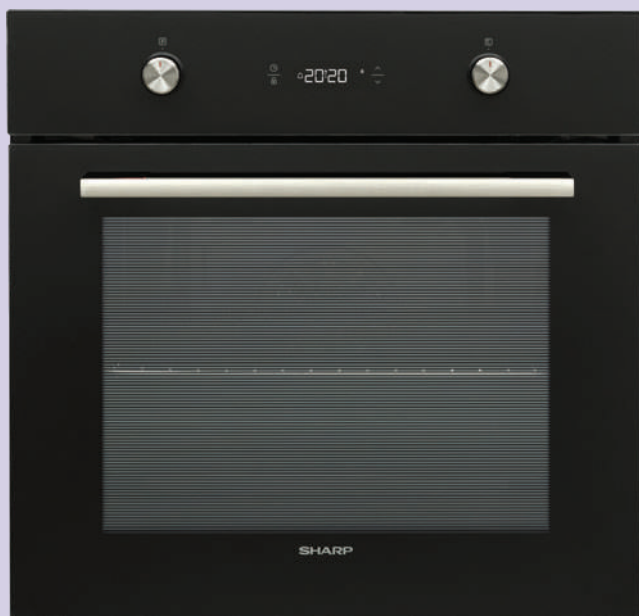

Volume & Oven Type: 69lt, Multifunction

Energy Class: A

Colour: Black

Cleaning Type: Easy to Clean Grey Enamel

Control Panel: FD Digital Touch Timer

Knob: Onis (PIPO)

Handle: Basic Margo Handle

Door: Full Inner Glass Door with Plastic Profiles
& Removable Inner Glass

Oven Light: Top

Rack Type: Wire rack + 1 set EasyFix standard
telescopic rails

Trays: 1 shallow tray, 1 deep tray
1 shallow tray, 1 deep tray

9 functions:

Ovenlight, Defrost, Fan+Ring, Top+Bottom,
Top+Bottom+Fan, Pizza, Grill, Double Grill,
Double Grill+Fan

K-50M22BNL



Volume & Oven Type: 65lt, Fan Assited

Energy Class: A

Colour: Black

Cleaning Type: Easy to Clean Gray Enamel

Control Panel: Mechanical Timer

Knob: Onis (PIPO)

Handle: Basic Margo Handle

Door: Full Inner Glass Door with Plastic Profiles
& Removable Inner Glass

Oven Light: Top

Rack Type: Molded rack

Trays: 1 shallow tray, 1 deep tray

8 functions:

Ovenlight, Defrost, Top+Bottom,
Top+Bottom+Fan, Bottom+Fan, Grill, Double
Grill, Double Grill+Fan

K-60M15BNL



Volume & Oven Type: 72 lt, Static

Energy Class: A

Colour: Black

Cleaning Type: Easy to Clean Gray Enamel

Control Panel: Mechanical Timer

Knob: Onis (PIPO)

Handle: Basic Margo Handle

Door: Full Inner Glass Door with Plastic Profiles

Oven Light: Top

Rack Type: Molded rack

Trays: 1 shallow tray, 1 deep tray

6 functions:

Top, Ovenlight, Top+Bottom, Bottom, Grill,
Double Grill



Built-in Ovens *Series I*

KA-73S56BSS

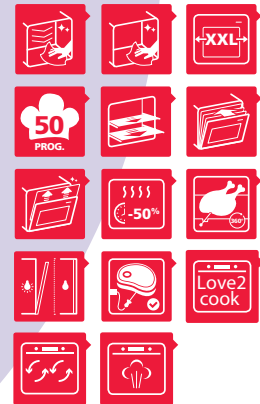

Volume & Cleaning Type: 78lt, Steam Assisted

Features: Air Curtain & Steam Assisted Cooking + PowerBoost

Cleaning Features: VapClean Plus

Energy Class: A

Colour: Black

Control Panel: Colour TFT Timer (11 languages)

Oven Type: Multifunctional oven + 150 Autocooking Programs

Oven Light: Top

Rack Type: Wire rack + 1 set of full telescopic rails

Door: Removable Inner Glass + SoftClosingDoor

Accessories: 1 shallow tray, 1 deep tray , 1 small tray + Pizza set (optional) + Meat Probe

10 functions:

Ovenlight, Defrost, Fan +Ring ,Top+Bottom, Top+Bottom+Fan, Pizza, Grill, Double Grill+Fan, VapClean Plus, Steam Assisted Cooking

K-71F28BM2

K-71F28IM2

K-71F28AM2



Volume & Cleaning Type: 78lt, Pyrolytic

Cooling Feature: ActiveCool Technology

Energy Class: A

Cleaning Features: 2 level Pyrolytic Cleaning

Control Panel: Touch+ Timer

Oven Type: Multifunctional Oven

Oven Light: Top

Rack Type: Wire rack + 1 set of full telescopic rails

Door: Removable Inner Glass + SoftClosingDoor

Trays: 1 shallow tray, 1 deep tray

9 functions:

Defrost, Fan+Ring, Top+Bottom,
Top+Bottom+Fan, Grill, Double Grill, Double
Grill+Fan, Pyrolysis

K-71V28IM2

K-71V28AM2

K-71V28BM2

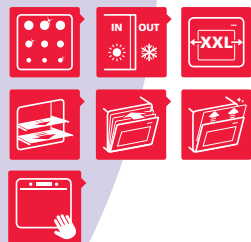

Volume & Cleaning Type: 78lt, Pyrolytic

Cooling Feature: ActiveCool Technology

Energy Class: A

Colour: Black / Antifingerprint Inox / Dark Inox

Control Panel: Touch+ Timer

Oven Type: Multifunctional oven

Oven Light: Top

Rack Type: Wire rack + 1 set of full telescopic rails

Door: Removable Inner Glass + SoftClosingDoor

Trays: 1 shallow tray, 1 deep tray

9 functions:

Defrost, Fan+Ring, Top+Bottom,
Top+Bottom+Fan, Grill, Double Grill, Double
Grill+Fan, Pyrolysis

KA-70S50BSS

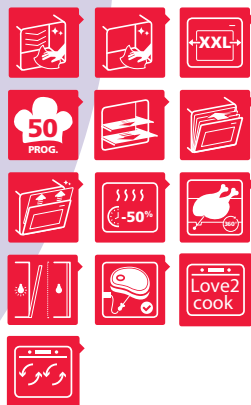

Volume & Cleaning Type: 78lt, Catalytic Cleaning & VapClean

Features: Air Curtain +150 Autocooking Programs

Energy Class: A

Colour: Black

Control Panel: Colour TFT Timer (11 languages)

Oven Type: Multifunctional Oven + PowerBoost

Oven Light: Top + Sides

Rack Type: Wire rack + 1 set of full telescopic rails

Door: Removable Inner Glass + SoftClosingDoor

Accessories: 3 trays (1 shallow, 1 deep, 1 small)
+ Pizza set (optional) + Meat Probe

10 functions:

Ovenlight, Defrost, Turbo*, Top+Bottom, Top+Bottom+Fan, Pizza, Grill+Turnspit, Double Grill+Turnspit, Double Grill+Fan+Turnspit, VapClean

KA-70T50BHH

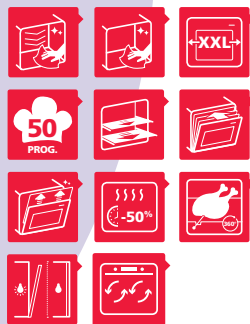
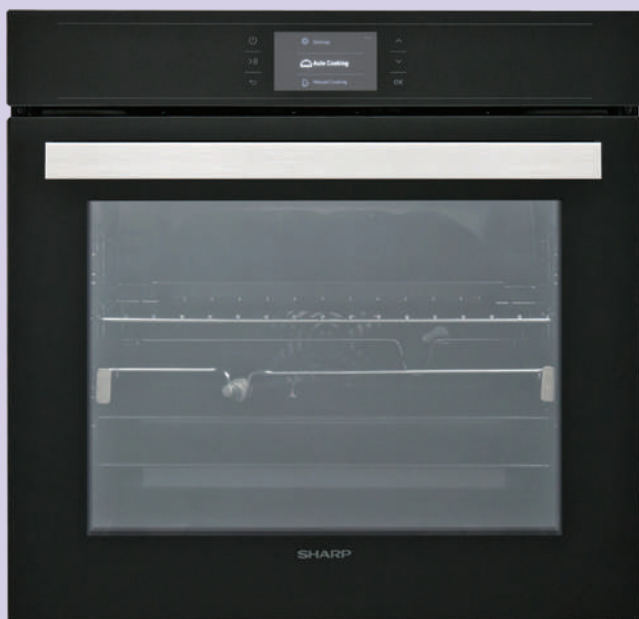

Volume & Cleaning Type: 78lt, Catalytic Cleaning & VapClean

Features: AirCurtain & 50 Autocooking Programs

Energy Class: A

Control Panel: Black Monochrome TFT Timer

Oven Type: Multifunctional Oven + PowerBoost +

Oven Light: (Top + Sides) + DoorSwitch

Rack Type: Wire rack + 1 set of full telescopic rails

Door: Removable Inner Glass + SoftClosingDoor

Trays: 1 shallow tray, 1 deep tray, 1 small tray

10 functions:

Ovenlight, Defrost, Fan+Ring, Top+Bottom, Top+Bottom+Fan, Pizza, Grill+Turnspit, Double Grill+Turnspit, Double Grill+Fan+Turnspit, VapClean

KA-70F19BM2



Volume & Cleaning Type: 78lt, Catalytic

Feature: Air Curtain

Energy Class: A

Colour: Black Glass

Control Panel: Full Touch Control Panel

Oven Type: Multifunctional Oven

Oven Light: Top

Rack Type: Wire rack + Standard Telescopic Rails

Door: Removable Inner Glass

Trays: 1 shallow tray, 1 deep tray

9 functions:

Ovenlight, Defrost, Fan+Ring, Top+Bottom, Top+Bottom+Fan, Pizza, Grill, Double Grill, Double Grill+Fan

KA-70V19BM2

KA-70V19IM2

KA-70V19AM2



Volume & Cleaning Type: 78lt, Catalytic

Feature: Air Curtain

Energy Class: A

Colour: Black / Antifingerprint Inox / Dark Inox

Control Panel: Touch+ Timer

Oven Type: Multifunctional Oven

Oven Light: Top

Rack Type: Wire rack + 1 set of standard telescopic rails

Door: Removable Inner Glass

Trays: 1 shallow tray, 1 deep tray, 1 small tray

9 functions:

Ovenlight, Defrost, Fan+Ring, Top+Bottom, Top+Bottom+Fan, Pizza, Grill, Double Grill, Double Grill+Fan

K-61V28BM1

K-61V28IM1



Volume & Cleaning Type: 69lt, Pyrolytic

Cooling Feature: ActiveCool Technology

Energy Class: A

Colour: Black / Antifingerprint Inox Panel

Control Panel: Touch+ Timer

Oven Type: Multifunctional Oven

Oven Light: Top

Rack Type: Wire rack

Door: Removable Inner Glass

Trays: 1 shallow tray, 1 deep tray

8 functions:

Defrost, Top+Bottom, Top+Bottom+Fan, Grill, Double Grill, Pyrolysis, Double Grill+Fan, Turbo*

K-61D27BM1

K-61D27IM1

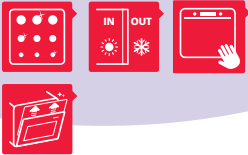

Volume & Oven Type: 69lt, Pyrolytic Fan Assisted

Cooling Feature: ActiveCool Technology

Energy Class: A

Colour: Black / Antifingerprint Inox Panel

Control Panel: Digital Timer / White

Oven Light: Top

Rack Type: Wire Rack

Door: Removable Inner Glass

Trays: 1 shallow tray, 1 deep tray

6 functions:

Defrost, Top+Bottom, Top+Bottom+Fan, Grill, Double Grill, Pyrolysis

K-60V19BQM

K-60V19IQM

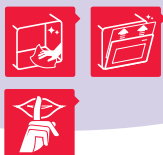

Volume & Oven Type: 69lt, Silent
Multifunctional

Cleaning Type: Catalytic Cleaning

Energy Class: A

Noise Level: 35 dBA

Colour: Black / Antifingerprint Inox Panel

Control Panel: Touch+ Timer

Oven Light: Top

Rack Type: Wire Rack

Door: Removable Inner Glass

Trays: 1 shallow tray, 1 deep tray

9 functions:

Ovenlight / Defrost / Fan+ring / Top+bottom /
Top+bottom+fan / Pizza / Grill / Double Grill /
Doublegrill+fan

K-60D19BM1

K-60D19IM1



Volume & Oven Type: 69lt, Multifunction

Energy Class: A

Colour: Black / Antifingerprint Inox Panel

Cleaning Type: Easy to Clean Gray Enamel

Control Panel: Touch Timer with White Color

Oven Light: Top

Rack Type: Wire rack + 1 set of standard telescopic rails

Door: Removable Inner Glass

Trays: 1 shallow tray, 1 deep tray

9 functions:

Ovenlight / Defrost / Fan+ring / Top+bottom / Top+bottom+fan / Pizza / Grill / Double Grill / Doublegrill+fan

KA-60D22BM1

KA-60D22IM1



Volume & Oven Type: 69lt, Fan Assited

Features: Air Curtain

Energy Class: A

Colour: Black / Antifingerprint Inox Panel

Cleaning Type: Easy to Clean Gray Enamel

Control Panel: Touch Timer

Oven Light: Top

Rack Type: Wire Rack

Door: Removable Inner Glass

Trays: 1 shallow tray, 1 deep tray

8 functions:

Ovenlight, Defrost, Top+Bottom,
Top+Bottom+Fan, Bottom+Fan, Grill, Double
Grill, Double Grill+Fan

K-60D22BM1

K-60D22IM1



Volume & Oven Type: 69lt, Fan Assited

Energy Class: A

Colour: Black / Antifingerprint Inox

Cleaning Type: Easy to Clean Gray Enamel

Control Panel: Touch Timer

Oven Light: Top

Rack Type: Wire Rack

Door: Removable Inner Glass

Trays: 1 shallow tray, 1 deep tray

8 functions:

Ovenlight, Defrost, Top+Bottom,
Top+Bottom+Fan, Bottom+Fan, Grill, Double
Grill, Double Grill+Fan

K-50M22BL2

K-50M22IL2



Volume & Oven Type: 65lt, Fan Assisted

Energy Class: A

Colour: Black / Antifingerprint Inox

Cleaning Type: Easy to Clean Gray Enamel

Control Panel: Mechanical Timer

Oven Light: Top

Rack Type: Molded rack

Trays: 1 shallow tray, 1 deep tray

8 functions:

Ovenlight, Defrost, Top+Bottom,
Top+Bottom+Fan, Bottom+Fan, Grill, Double
Grill, Double Grill+Fan

K-60M15BL2

K-60M15IL2



Volume & Oven Type: 72 lt, Static

Energy Class: A

Colour: Black / Antifingerprint Inox

Cleaning Type: Easy to Clean Gray Enamel

Control Panel: Mechanical Timer

Oven Light: Top

Rack Type: Molded rack

Trays: 1 shallow tray, 1 deep tray

6 functions:

Top, Ovenlight, Top+Bottom, Bottom, Grill,
Double Grill



Built-in Double Ovens

K-90D10BM2-EN



Volume & Cleaning Type: 37lt & 74lt, Catalytic Cleaning

Energy Class: A

Control Panel: Digital Touch Timer

Feature: PureBlack Oven Glass

Handle: Black Margo Handle

Door: Full Inner Glass Door with Plastic Profiles

Oven Light: Top

Rack Type: Wire rack

Other Features: 1 set of EasyFix Full Telescopic Rails

Accessories: 1 shallow tray, 2 chrome wire grid, 1 inner tray grid, 1 grill pan handle set

Functions

Top Oven: Ovenlight, Top+Bottom, Bottom, Top, Grill, Double Grill

Main Oven: Ovenlight, Defrost, Fan+Ring, Top+Bottom, Top+Bottom+Fan, Pizza, Grill, Double Grill, Double Grill+Fan, VapClean

K-90D06BM1-EN



Volume & Cleaning Type: 37lt & 74lt, Easy to Clean Enamel

Energy Class: A

Control Panel: Digital Touch Timer

Knob & Handle: Onis PIPO Knob & Black Margo Handle

Door: Full Inner Glass Door with Plastic Profiles

Oven Light: Top & Main Oven

Feature: Removable Inner Glass

Rack Type: Molded rack

Accessories: 1 shallow tray, 2 chrome wire grid, 1 inner tray grid, 1 grill pan handle set

Functions

Top Oven: OvenLight, Top+Bottom, Bottom, Top, Grill, Double Grill

Main Oven: Defrost / Top+Bottom / Top+Bottom+Fan



Built-in Hobs



Premium Features

Summary

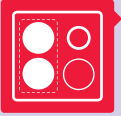

CookBridge

The ultimate in versatility CookBridge provides flexibility for pans of all shapes and sizes. By simply combining two induction zones you can create an extra large zone for big pots and pans



Stop&Go

Freeze time when you need to. Our Stop&Go technology enables you to pause and take that all important call when cooking, then press again to continue



AutoHeatControl

Simple yet effective, Sharp puts the most common cooking tasks at your fingertips, allowing you to boil, fry, melt chocolate and keep your food warm at the touch of a button



EasyToClean Surface

The smooth glass ceramic surface is especially easy to clean



SliderTouch

Intuitive sliding controls allow you to select the power level easily



TimerFunction

When the hob is switched on, an independent timer (1 to 99 minutes) can be programmed for every cooking zone so that they switch off automatically. When the hob is switched off, you also have the possibility to set a minute minder



InductionBoost

Maximum power in seconds for a speed-up heating and a cooking time reduction



Child Lock

Young minds are inquisitive but there's no need to worry with this safety feature that keeps wandering fingers at bay. When it is activated, no control can be changed



Hot surface indicator

After switching off the cooking zone, an "H" will be displayed until the assigned cooking zone temperature is in an uncritical level. It reminds you not to touch a hot cooking zone. You can also use the residual heat for defrosting or maintaining a dish warm



Safety switch off function

If you forget to switch off the hob, it's not a problem. Every cooking zone will be switched off automatically after a define maximum operation time if the heat setting is not modified



Extended2xZone

This extendable cooking zone allows you flexibility to cook with pans of different size perfectly



2xZone

Small to medium size variation, our 2xZone allows true flexibility when it comes to selecting the perfect size for your pans



3xZone

Small to medium size variation, our 3xZone allows true flexibility when it comes to selecting the perfect size for your pans

CookBridge

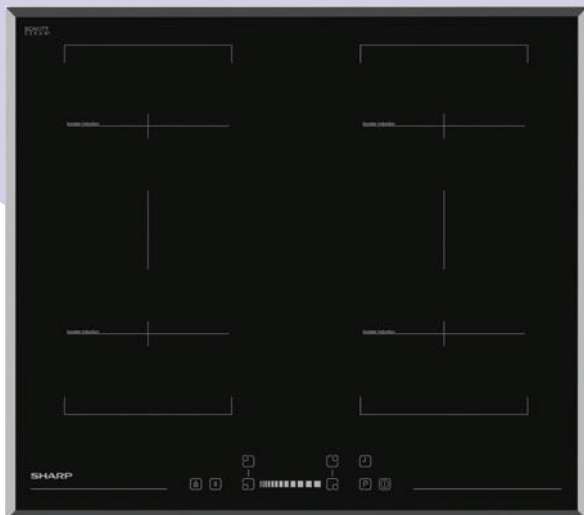

The CookBridge enables you 2 options: to cook 2 dishes separately in different zones or to turn the 2 cooking zones into 1 large zone which automatically adapts to the size and positions of the utensil.

SliderTouch

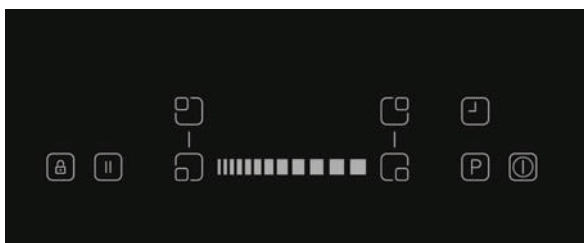

SliderTouch controls allow you direct access to your desired cooking level for each heating zone separately by a simple touch of a finger: temperature is adjusted instantly.



InductionBoost

InductionBoost increases the power of the heating zone to provide extreme heat intensity to the pot.



AutoHeatControl

Convenience

*pre-setting right power, avoiding burning,
standardized cooking experience*

+ Time Saving



Frying

Fixes the cooking zone in frying temperature (160°C)



Keep Warm

Keeps the cooking zone in 50°C



Boiling

Fixes the cooking zone in boiling temperature (100°C)



Chocolate Melting

Keeps the cooking zone in 40°C



Stop&Go

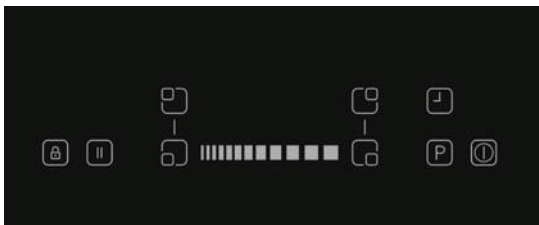

When you press Stop&Go button, the power of all activated heaters is reduced to a keep warm setting. When you touch the button again, the heaters automatically return to the previously selected level.



Separate Timer for Each Zone

When the hob is switched on, an independent timer (1 to 99 minutes) can be programmed for every cooking zone so that they switch off automatically. When the hob is switched off, you also have the possibility to set a minute minder.

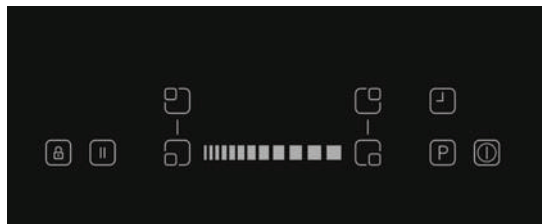

Schott Glass

The whole Sharp hob range is made of Schott CERAN glass ceramic. «Made in Germany» quality.



SCHOTT
CERAN®

Design



Entry

2-side inox frame
No bevel



Mid

No frame
Front bevel



High

No frame
4-side bevel

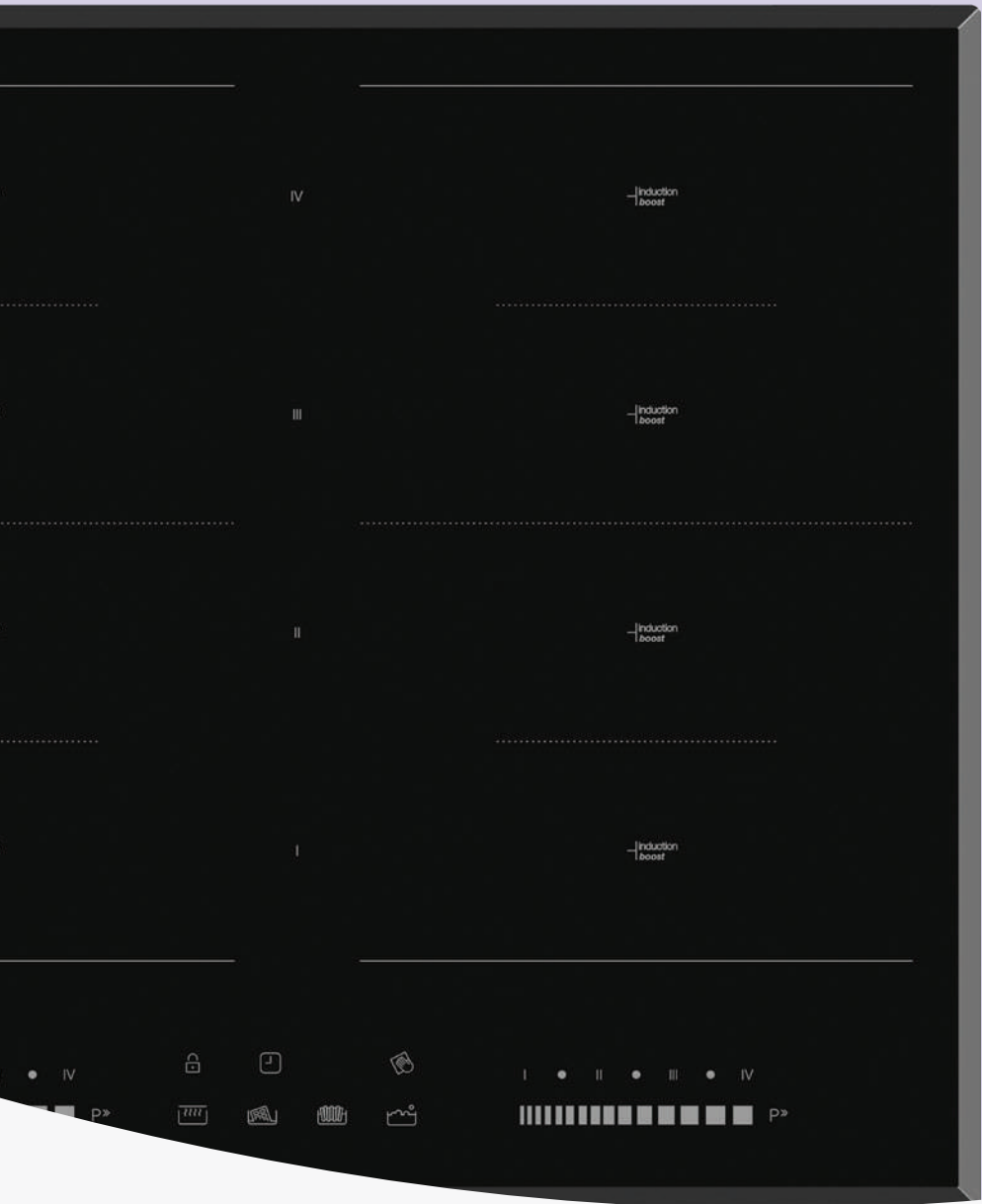

Built-in Hobs

Induction Hobs

KH-6I46CS00

60 cm Flexible Induction Hob

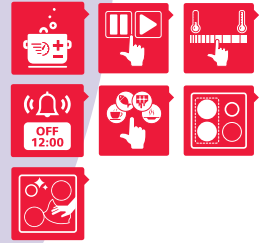

Width & Number of Zones: 60cm, 8 Zones

Colour: Black Colour

Aesthetics: No Frame, 4-Side Bevel

Total Power: 7200 W

24cmx38cm 3600W

Control Type: Multi SliderTouch Control

Feature 1: 2 V-Flex zones (Full Flexible)

Feature 2: AutoSense

Feature 3: 8 Independantly Controllable Timers

Feature 4: Hot Surface Indicator

Feature 5: Key Lock

Feature 6: Stop&Go

Feature 7: AutoHeatControl

Frying

Keep Warm

Boiling

Chocolate Melting

SCHOTT
CERAN®



Frying



Keep Warm



Boiling



Chocolate
Melting

KH-9I40CS00

90 cm Induction Hob with Double Bridge Zone

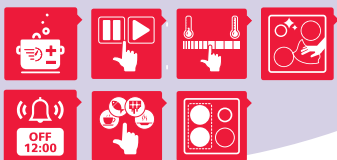

Width & Number of Zones: 90cm, 5 zones

Colour: Black colour

Aesthetics: No frame, 4-side bevel

Total Power: 10800 W

2x16cm 1400W /Boost 1800W

2x16cm 1400W /Boost 1800W

1x25cm 2800W /Boost 3500W

Control Type: MultiSlider Touch Control

Feature 1: Double CookBridge (Flexible Induction)

Feature 2: 5 Independent Timer

Feature 3: Hot Surface Indicator

Feature 4: Key Lock

Feature 5: Stop&Go

Feature 6: AutoHeatControl

Feature 7: AutoHeatControl

Frying

Keep Warm

Boiling

Chocolate Melting

SCHOTT
CERAN®



Frying



Keep Warm



Boiling



Chocolate Melting

KH-9I39CS00

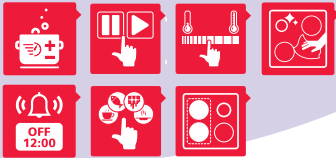

Width & Number of Zones: 90cm, 5 zones

Colour: Black Colour

Aesthetics: No Frame, 4-Side Bevel

Total Power: 10800 W

2x16cm 1400W /Boost 1800W

2x20cm 2100W /Boost 2500W

1x25cm 2800W /Boost 3500W

Control Type: MultiSliderTouch Control

Feature 1: Single CookBridge (Flexible Induction)

Feature 2: 5 Timers

Feature 3: Hot Surface Indicator

Feature 4: Key Lock

Feature 5: Stop&Go

Feature 6: Easy to Clean Surface

Feature 7: AutoHeatControl

Frying

Keep Warm

Boiling

Chocolate Melting

SCHOTT
CERAN®



Frying



Keep Warm



Boiling



Chocolate
Melting

KH-9I26CT00



Width & Number of Zones: 90cm, 5 zones

Colour: Black Colour

Aesthetics: No Frame, 4-Side Bevel

Total Power: 10800 W

2x16cm 1400W /Boost 1800W

2x20cm 2100W /Boost 2500W

1x25cm 2800W /Boost 3500W

Control Type: Front Touch Control

Feature 1: 5 Timers

Feature 2: Hot Surface Indicator

Feature 3: Key Lock

Feature 4: Stop&Go

Feature 5: Easy to Clean Surface

KH-7I19CS00

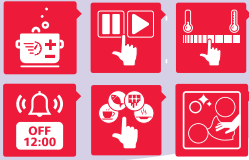

Width & Number of Zones: 60cm, 4 zones

Colour: Black Colour,

Aesthetics: No Frame, 4-Side Bevel

Total Power: 7400 W

3x16cm 1400W /Boost 1800W

1x20cm 2100W /Boost 2500W

Control Type: Slider Touch Control

Feature 1: 4 Timers

Feature 2: Hot Surface Indicator

Feature 3: Key Lock

Feature 4: Stop&Go

Feature 5: AutoHeatControl

Frying

Keep Warm

Boiling

Chocolate Melting

Feature 6: Easy to Clean Surface

SCHOTT
CERAN®



Frying



Keep Warm



Boiling



Chocolate
Melting

KH-7I18CT00



Width & Number of Zones: 78cm, 4 zones
Colour: Black Colour
Aesthetics: No Frame, 4-Side Bevel
Total Power: 7400W
2x16cm 1400W /Boost 1800W
2x20cm 2100W /Boost 2500W
Control Type: Touch Control
Feature 1: 4 Timers
Feature 2: Hot Surface Indicator
Feature 3: Key Lock
Feature 4: Stop&Go
Feature 5: AutoHeatControl
Frying Keep Warm
Boiling Chocolate Melting
Feature 6: Easy to Clean Surface

SCHOTT
CERAN®



Frying



Keep Warm



Boiling



Chocolate Melting

KH-6I19FTPP

Plug & Play Induction Hob / Power Management



Width & Number of Zones: 60 cm, 4 zones

Colour: Black Colour

Aesthetics: 2-Side Frame, No Bevel

Total Power:

2x16cm 1400W / Boost 1800W

2x21cm 2100W / Boost 2500W

Feature 1: InductionBoost, Pan Detection, Timer

Feature 2: Stop&Go , Key Lock

Feature 3: Hot Surface Indicator

Feature 4: Easy to Clean Surface

Plug Options: 13A, 15A, 16A and 32 A plug options

Current(A)	Max Power(W)
13A	2900W
15A	3500W
16A	3600W
32A	7400W

KH-6I38CS00

Double Bridge Induction Hob

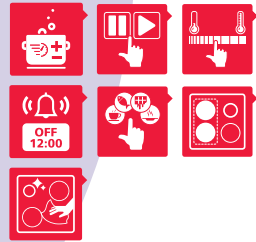

Width & Number of Zones: 60cm, 4 zones

Colour: Black Colour

Aesthetics: No Frame, 4-Side Bevel

Total Power: 7400 W

4x16cm 1400W /Boost 1800W

Control Type: SliderTouch Control,

Feature 1: Double CookBridge (Flexible Induction)

Feature 2: 4 Timers

Feature 3: Hot Surface Indicator

Feature 4: Key Lock

Feature 5: Stop&Go

Feature 6: Easy to Clean Surface

Feature 7: AutoHeatControl

Frying

Keep Warm

Boiling

Chocolate Melting

SCHOTT
CERAN®



Frying



Keep Warm



Boiling



Chocolate
Melting

KH-6I38FS00

Double Bridge Induction Hob

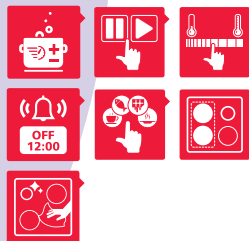
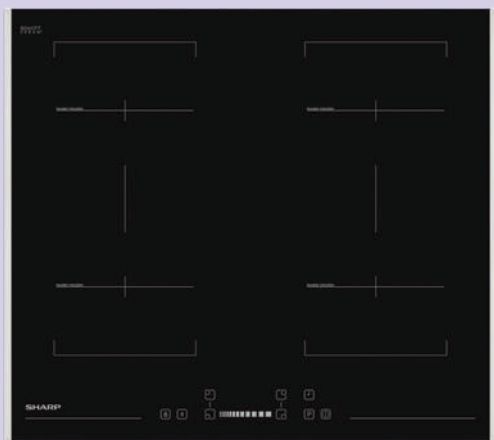

Width & Number of Zones: 60cm, 4 zones

Colour: Black Colour

Aesthetics: 2-Side Frame, No Bevel

Total Power: 7400 W

4x16cm 1400W /Boost 1800W

Control Type: SliderTouch Control,

Feature 1: Double CookBridge (Flexible Induction)

Feature 2: 4 Timers

Feature 3: Hot Surface Indicator

Feature 4: Key Lock

Feature 5: Stop&Go

Feature 6: Easy to Clean Surface

Feature 7: AutoHeatControl

Frying

Keep Warm

Boiling

Chocolate Melting

SCHOTT
CERAN®



Frying



Keep Warm



Boiling



Chocolate
Melting

KH-6I35NS00

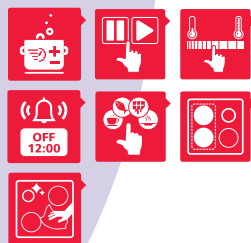
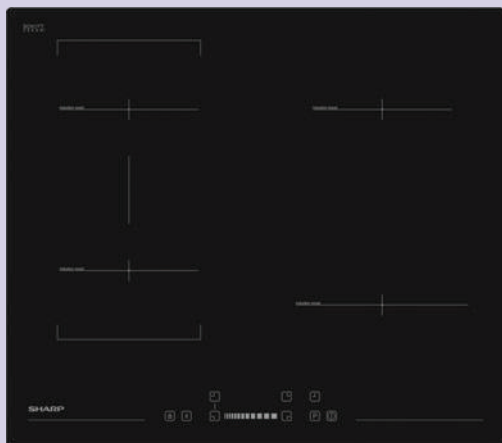

Width & Number of Zones: 60cm, 4 zones

Colour: Black colour

Aesthetics: No Frame, No Bevel

Total Power: 7400 W

3x16cm 1400W /Boost 1800W

1x20cm 2100W /Boost 2500W

CookBridge (35,4x16cm) : 2800W / Boost 3600W

Feature 1: Single CookBridge (Flexible Induction)

Feature 2: 4 Timers

Feature 3: Hot Surface Indicator

Feature 4: Key Lock

Feature 5: Stop&Go

Feature 6: AutoHeatControl

Frying

Keep Warm

Boiling

Chocolate Melting

Feature 7: Easy to Clean Surface

SCHOTT
CERAN®



Frying



Keep Warm



Boiling



Chocolate
Melting

KH-6I27CS00

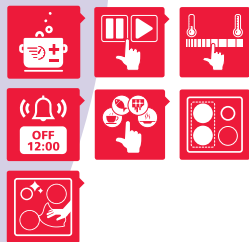
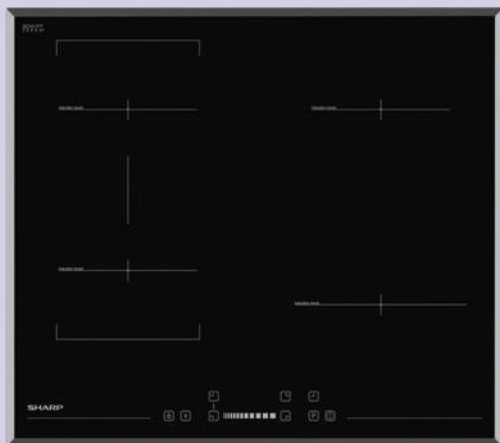

Width & Number of Zones: 60cm, 4 zones

Colour: Black Colour,

Aesthetics: No Frame, 4-Side Bevel

Total Power: 7400 W

3x16cm 1400W /Boost 1800W

1x20cm 2100W /Boost 2500W

CookBridge (35,4x16cm) : 2800W Boost 3600W

Control Type: Slider Touch Control

Feature 1: Single CookBridge (Flexible Induction)

Feature 2: 4 Timers

Feature 3: Hot Surface Indicator

Feature 4: Key Lock

Feature 5: Stop&Go

Feature 6: AutoHeatControl

Frying Keep Warm

Boiling Chocolate Melting

Feature 7: Easy to Clean Surface

SCHOTT
CERAN®



Frying



Keep Warm



Boiling



Chocolate
Melting

KH-6I34BS00

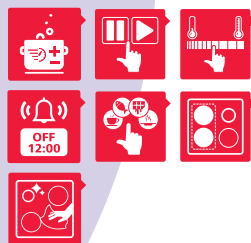
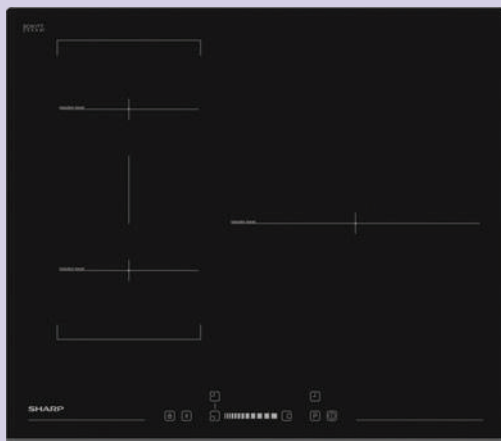

Width & Number of Zones: 60cm, 3 zones

Colour: Black Colour,

Aesthetics: No Frame, Front Bevel

Total Power: 7200 W

2x16cm 1400W /Boost 1800W

1x29cm 2800W /Boost 3500W

CookBridge (35,4x16cm) : 2800W /Boost 3600W

Control Type: Slider Touch Control

Feature 1: Single CookBridge (Flexible Induction)

Feature 2: 3 Timers

Feature 3: Hot Surface Indicator

Feature 4: Key Lock

Feature 6: Stop&Go

Frying

Keep Warm

Boiling

Chocolate Melting

Feature 7: Easy to Clean Surface

SCHOTT
CERAN®



Frying



Keep Warm



Boiling



Chocolate
Melting

KH-6I31BS00

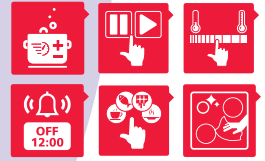

Width & Number of Zones: 60cm, 3 zones

Colour: Black Colour

Aesthetics: No Frame, Front Bevel

Total Power: 7200 W

1x16cm 1400W /Boost 1800W

1x21cm 2100W /Boost 2500W

1x29cm 2800W /Boost 3500W

Control Type: Slider Touch Control

Feature 1: 3 Timers

Feature 2: Hot Surface Indicator

Feature 3: Key Lock

Feature 4: Stop&Go

Feature 5: AutoHeatControl

Frying Keep Warm

Boiling Chocolate Melting

Feature 6: Easy to Clean Surface

SCHOTT
CERAN®



Frying



Keep Warm



Boiling



Chocolate Melting

KH-6I31NT00

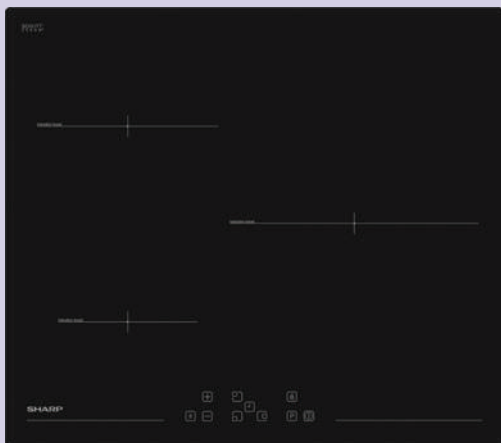

Width & Number of Zones: 60cm, 4 zones

Colour: Black Colour

Aesthetics: Front Bevel

Total Power: 7400 W

1x16cm 1400W /Boost 1800W

1x21cm 2100W /Boost 2500W

1x29cm 2800W /Boost 3500W

Control Type: Touch Control,

Feature 1: 3 Timers

Feature 2: Hot Surface Indicator

Feature 3: Key Lock

Feature 4: Stop&Go

Feature 5: AutoHeatControl

Frying

Keep Warm

Boiling

Chocolate Melting

Feature 6: Easy to Clean Surface

SCHOTT
CERAN®



Frying



Keep Warm



Boiling



Chocolate
Melting

KH-6I19BS00

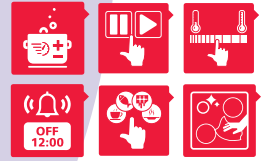

Width & Number of Zones: 60cm, 4 zones

Colour: Black Colour

Aesthetics: Front Bevel

Total Power: 7400 W

2x16cm 1400W /Boost 1800W

2x20cm 2100W /Boost 2500W

Control Type: Slider Touch Control,

Feature 1: 4 Timers

Feature 2: Hot Surface Indicator

Feature 3: Key Lock

Feature 4: Stop&Go

Feature 5: AutoHeatControl

Frying

Keep Warm

Boiling

Chocolate Melting

Feature 6: Easy to Clean Surface

SCHOTT
CERAN®



Frying



Keep Warm



Boiling



Chocolate
Melting

KH-6I19FT00

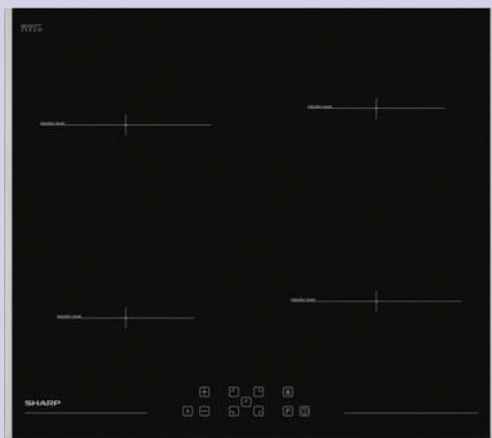

Width & Number of Zones: 60cm, 4 zones

Colour: Black Colour

Aesthetics: 2-Side Inox Frame, No Bevel

Total Power: 7400 W

2x16cm 1400W /Boost 1800W

2x20cm 2100W /Boost 2500W

Control Type: Front Touch Control,

Feature 1: 4 Timers

Feature 2: Hot Surface Indicator

Feature 3: Key Lock

Feature 4: Stop&Go

Feature 5: AutoHeatControl

Frying

Keep Warm

Boiling

Chocolate Melting

Feature 6: Easy to Clean Surface

SCHOTT
CERAN®



Frying



Keep Warm



Boiling



Chocolate
Melting

KH-6I45FT00



Width & Number of Zones: 60cm, 4 zones

Colour: Black Colour

Aesthetics: No Frame, No Bevel

Hob Configuration & Power: 2x160mm, 2x210mm

160mm zones: 1300 W (current→1400/1800)

210mm zones: 1500 W (current→2100/2500)

210mm zone front right: 1700 W (Boost function)

Remark: Boost function is only for 210mm front right zone

Feature 1: Timer

Feature 2: Child lock

Feature 3: Key lock

Feature 4: Smart Pause

KH-3I25NT00

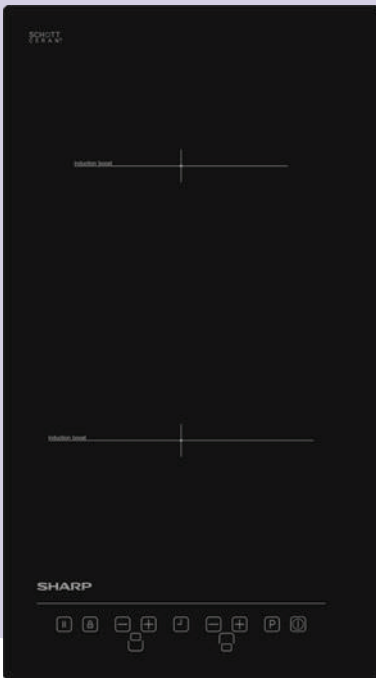

Width & Number of Zones: 30cm, 2 zones

Colour: Black Colour

Aesthetics: No Frame, No Bevel

Total Power: 3600 W

1x16cm 1400W /Boost 1800W

1x21cm 2100W /Boost 2500W

Control Type: Front Touch Control

Feature 1: Timer

Feature 2: Hot Surface Indicator

Feature 3: Key Lock

Feature 4: Stop&Go

SCHOTT
CERAN®

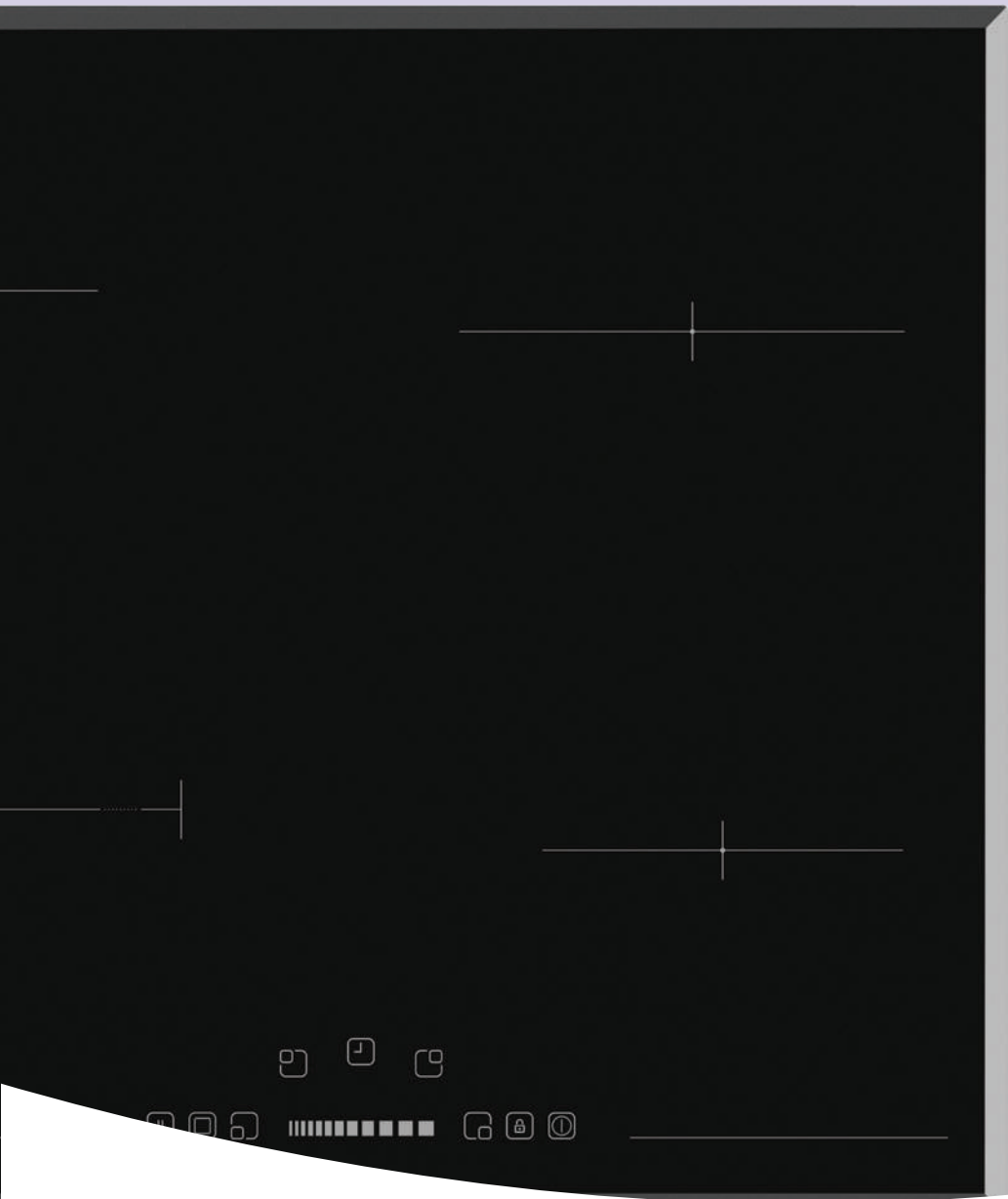

Built-in Hobs *Vitroceramic Hobs*

KH-6V09CS00

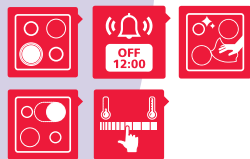

Width & Number of Zones: 60cm, 4 Highlight

Colour: Black Colour

Aesthetics: No Frame, 4-Side Bevel

Total Power: 5900 W

2x14,5cm : 1200W each

1x18cm "2xZone" : 1700W

1x14,5-25,2cm "Extended 2xZone" : 1800W

Control Type: SliderTouch Control

Feature 1: 4 Timers

Feature 2: Hot Surface Indicator

Feature 3: Easy to Clean Surface

KH-6V08BS00

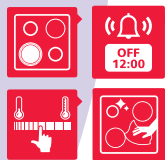

Width & Number of Zones: 60cm, 4 Highlight

Colour: Black Colour

Aesthetics: 2-Side Inox Frame, No Bevel

Total Power: 5900 W

2x14,5cm : 1200W each

1x18cm : 1800W

1x18cm "2xZone" : 1700W

Control Type: Front Slider Control

Feature 1: 4 Timers

Feature 2: Hot Surface Indicator

Feature 3: Easy to Clean Surface

KH-6V13BS00

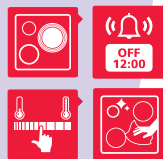
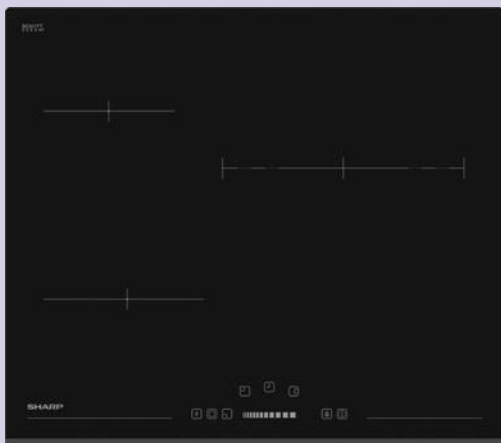

Width & Number of Zones: 60cm, 3 Highlight

Colour: Black Colour

Aesthetics: No Frame, Front Bevel

Total Power: 5700 W

1x14,5cm : 1200W

1x18cm : 1800W

1x29cm "3xZone" : 2700W

Control Type: SliderTouch Control,

Feature 1: 3 Timers

Feature 2: Hot Surface Indicator

Feature 3: Easy to Clean Surface

KH-6V08FT00

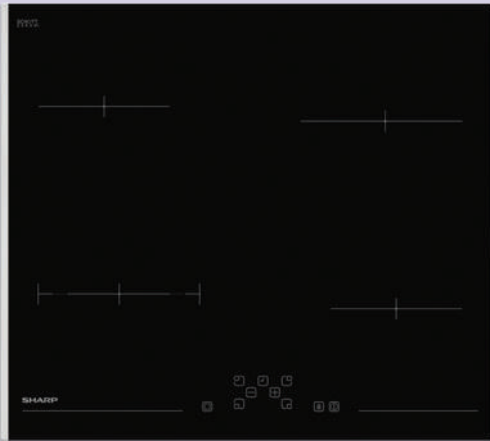

Width & Number of Zones: 60cm, 4 Highlight

Colour: Black Colour

Aesthetics: 2-Side Inox Frame, No Bevel

Total Power: 5900 W

2x14,5cm : 1200W each

1x18cm : 1800W

1x18cm "2xZone" : 1700W

Control Type: Front Touch Control

Feature 1: 4 Timers

Feature 2: Hot Surface Indicator

Feature 3: Easy to Clean Surface

KH-3V19NT00

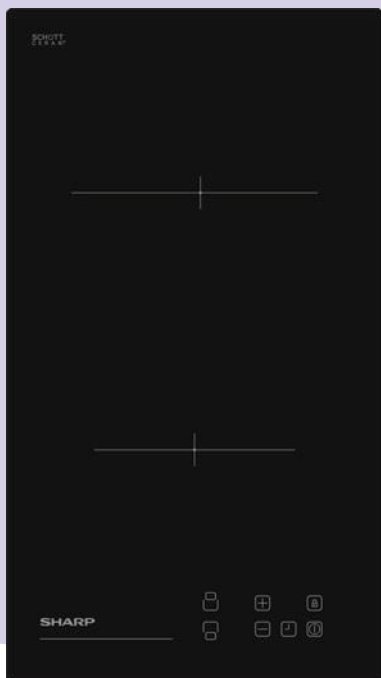

Width & Number of Zones: 30cm, 2 Highlight

Colour: Black Colour

Aesthetics: No Frame, No Bevel

Total Power: 3000W

1x14,5cm : 1200W

1x18cm : 1800W

Control Type: Front Touch Control,

Feature 1: Timer

Feature 2: Hot Surface Indicator

Feature 3: Easy to Clean Surface



Oven-Hob
Poly Sets

K-62V19IM1 (Mid) Poly Oven

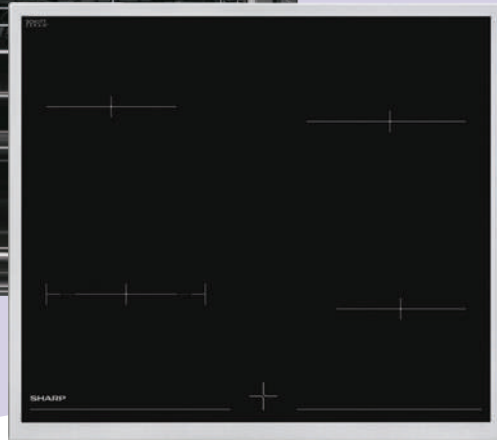

Volume & Cleaning Type: 69lt, Grey Enamel

Hob Type: Combined with Entry Poly Vitro Hob

Energy Class: A

Colour: Antifingerprint Inox Panel

Control Panel: Touch+ Timer

Oven Type: Multifunctional oven

Oven Light: Top

Rack Type: Wire rack

Door: Removable Inner Glass

Trays: 1 shallow tray,1 deep tray

9 functions:

Ovenlight, Defrost, Top+Bottom,
Top+Bottom+Fan, Bottom+Fan, Grill, Double
Grill, Double Grill+Fan, Fan+Ring

K-62V19IM0 (Mid) Poly Oven

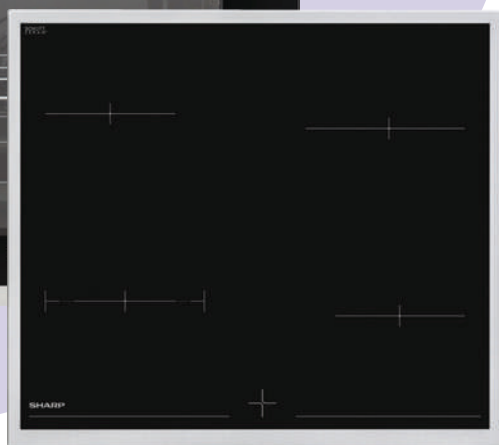

Volume & Cleaning Type: 69lt, Grey Enamel

Hob Type: Combined with Entry Poly Vitro Hob

Feature: Air Curtain

Energy Class: A

Colour: Antifingerprint Inox Panel

Control Panel: Touch+ Timer

Oven Type: Multifunctional Oven

Oven Light: Top

Rack Type: Wire rack

Door: Removable Inner Glass

Trays: 1 shallow tray, 1 deep tray

9 functions:

Ovenlight, Defrost, Top+Bottom, Top+Bottom+Fan, Bottom+Fan, Grill, Double Grill, Double Grill+Fan, Fan+Ring

KA-72D19IM2 (High) Poly Oven



Volume & Cleaning Type: 78lt, Catalytic (Back Panel)

Hob Type: Combined with Entry Poly Induction Hob

Feature: Air Curtain

Energy Class: A

Colour: Antifingerprint Inox Panel

Control Panel: Touch Timer

Oven Type: Multifunctional Oven

Oven Light: Top

Rack Type: Wire rack + 1 set of standard telescopic rails

Door: Removable inner glass

Trays: 1 shallow tray, 1 deep tray, 1 small tray

9 functions:

Ovenlight, Defrost, Top+Bottom, Top+Bottom+Fan, Bottom+Fan, Grill, Double Grill, Double Grill+Fan, Fan+Ring

Entry Poly Vitroceramic Hob

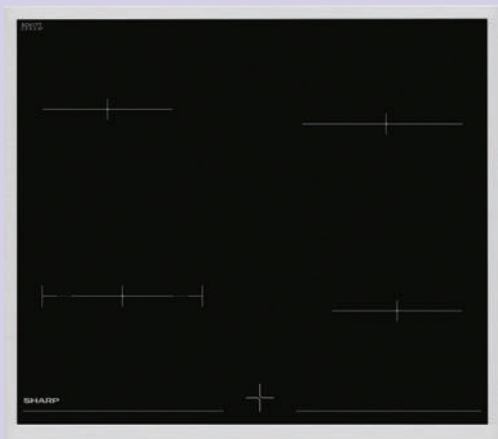

Width & Number of Zones: 60cm, 4 Highlight

Oven Combination: Combined with Entry / Mid Poly Oven

Colour: Black Colour

Aesthetics: 4-Side Inox Frame, No Bevel

Total Power: 5900W

2x14,5cm : 1200W each

1x18cm : 1800W

1x18cm "2xZone" : 1700W

Control Type: Hob Control from the knobs of Oven

Feature 1: 4 Timers

Feature 2: Hot Surface Indicator

Feature 3: Easy to Clean Surface

Mid Vitroceramic Hob

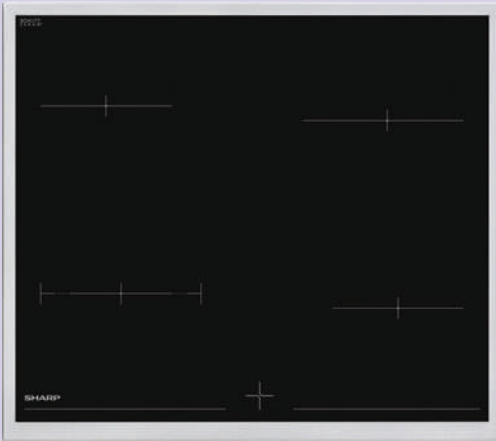

Width & Number of Zones: 60cm, 4 Highlight

Oven Combination: Combined with Entry / Mid Poly Oven

Colour: Black Colour

Aesthetics: 4-Side Inox Frame, No Bevel

Total Power: 5900 W

2x14,5cm : 1200W each

1x18cm "2xZone" : 1700W

1x14,5-25,2cm "Extended 2xZone" : 1800W

Control Type: Hob Control through Knobs on Oven

Feature 1: Hot Surface Indicator

Feature 2: Easy to Clean Surface

Poly Induction Hob



Width & Number of Zones: 60cm, 4 zones

Oven Combination: Combined with High Poly Oven

Colour: Black colour

Aesthetic: 4-Side Inox Frame, No Bevel

Total Power: 7400 W

2x16cm 1400W / Boost 1800W

2x20cm 2100W / Boost 2500W

Control Type: Hob Control through Knobs on Oven

Feature 1: Hot Surface Indicator,

Feature 2: 4 Timers

Feature 3: Key Lock

Feature 4: Stop&Go



Hoods

KL-61TTBLM

60 cm T-Type



Width & Hood Type: 60 cm, T Type

Colour: Black Colour

Airflow of motor max: 700 m3/h

Noise Level 3 : 62 dB (Speed Level 3)

Noise Level Boost: 70 dB (Boost)

Control Type: Touch on Glass

Feature 1: Timer/Boost

Feature 2: 2 x LED Light

Energy Class: A



KL-91TTBLM

90 cm T-Type



Width & Hood Type: 90 cm, T Type

Colour: Black Colour

Airflow of motor max: 725 m³/h

Noise Level 3: 62 dB (Speed Level 3)

Noise Level Boost: 70 dB (Boost)

Control Type: Touch on Glass

Feature 1: Timer/Boost

Feature 2: 2 x LED Light

Energy Class: A

KL-61TTILM

60 cm T-Type



Width & Hood Type: 60 cm, T Type

Colour: Inox Colour

Airflow of motor max: 700 m³/h

Noise Level 3: 62 dB (Speed Level 3)

Noise Level Boost: 70 dB (Boost)

Control Type: Touch on Glass

Feature 1: Timer/Boost

Feature 2: 2 x LED Light

Energy Class: A

KL-91TTILM

90 cm T-Type



Width & Hood Type: 90 cm, T Type

Colour: Inox Colour

Airflow of motor max: 725m³/h

Noise Level 3: 62 dB (Speed Level 3)

Noise Level Boost: 70 dB (Boost)

Control Type: Touch on Glass

Feature 1: Timer/Boost

Feature 2: 2 x LED Light

Energy Class: A

KL-61VMBLL-EU

60 cm Vertical

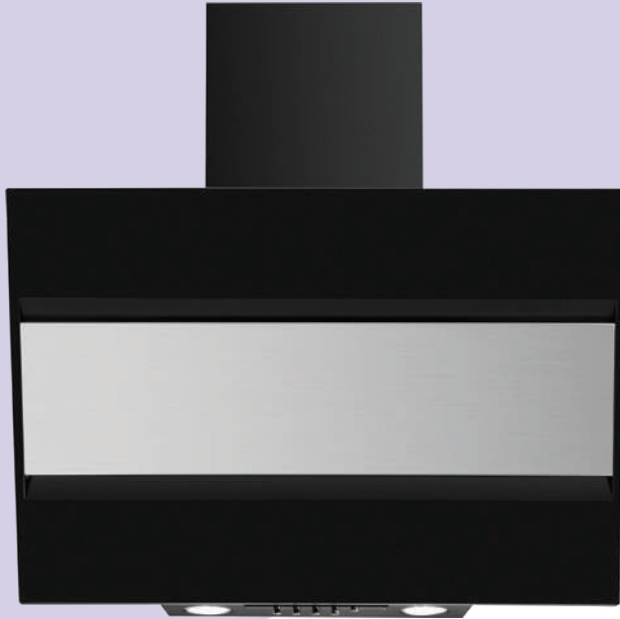

Width & Hood Type: 60cm, Vertical

Colour: Black Colour

Airflow of motor max: 440 m3/h

Noise Level 3: 68 dB (Speed Level 3)

Control Type: Mechanical buttons

Feature 1: 2 x LED Light

Energy Class: C



KL-61VTBLM

60 cm Vertical



Width & Hood Type: 60cm, Vertical

Colour: Black Colour

Airflow of motor max: 760 m3/h

Noise Level 3: 65dB (Speed Level 3)

Noise Level Boost: 71 dB (Boost)

Control Type: Touch on Glass

Feature 1: Timer/Boost

Feature 2: 2 x Movable LED Spot Lights

Energy Class: A

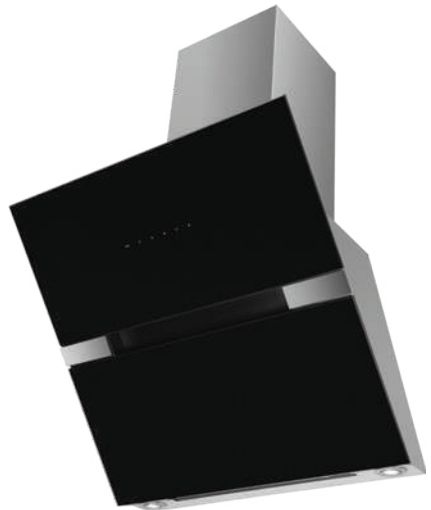

KL-81VTIHH/ KL-81VTAHH

80 cm Vertical



Width & Hood Type: 80cm, Vertical

Colour: Inox Add-on + Inox Body/ Dark Inox Add-on +Dark Inox Body

Airflow of motor max: 705 m3/h

Noise Level 3: 63dB (Speed Level 3)

Noise Level Boost: 70dB (Boost)

Control Type: Touch Control

Feature 1: Timer/Boost

Feature 2: 2 x Movable LED Spot Lights

Energy Class: A+

KL-91VBMH

90 cm Vertical



Width & Hood Type: 90cm, Vertical

Colour: Black Glass, Inox Body

Airflow of motor max: 780 m3/h

Noise Level 3: 65dB (Speed Level 3)

Noise Level Boost: 70dB (Boost)

Control Type: Touch on glass

Feature 1: Timer/Boost

Feature 2: 2 x Movable LED Spot Lights

Energy Class: A

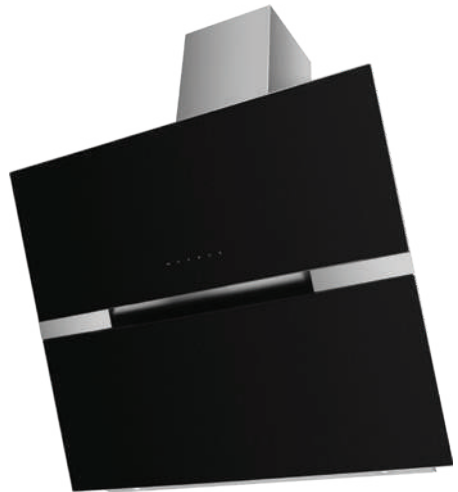

KL-91VWMH

90 cm Vertical

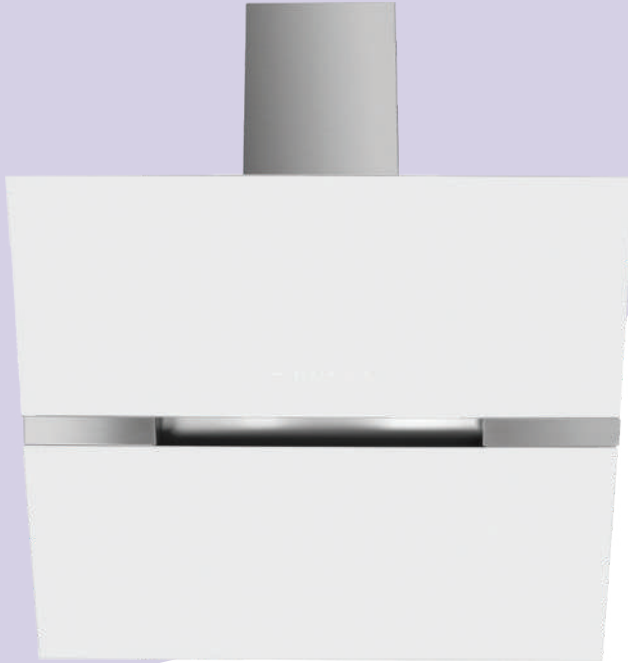

Width & Hood Type: 90cm, Vertical

Colour: White Glass, Inox Body

Airflow of motor max: 780 m3/h

Noise Level 3: 65dB (Speed Level 3)

Noise Level Boost: 70dB (Boost)

Control Type: Touch on Glass

Feature 1: Timer

Feature 2: 2 x Movable LED Spot Lights

Energy Class: A



KL-62BTBMH

60 cm Built-in



Width & Hood Type: 60cm, Built-in

Colour: Black

Airflow of motor max (Boost): 680 m³/h

Noise Level 3: 62dB (Speed Level 3)

Noise Level Boost: 69dB (Boost)

Control Type: Touch Control + Remote

Feature 1: Led Stripe

Feature 2: Timer

Energy Class: A



KL-630MILL

60 cm Built-under



Width & Hood Type: 60cm, Built-Under

Colour: Inox

Airflow of motor max (Boost): 180 m³/h

Noise Level 3: 63 dB (Speed Level 3)

Control Type: Mechanical Rotary

Feature 1: 2 x Movable LED Spot Lights

Energy Class: D





Built-in Dishwashers

Premium Features

Summary



AutoDoor

This technology opens the door at the end of the washcycle to assist the drying process, saving energy.



DualProWash

Helps tackle the dirtiest of pans in the bottom, while taking care of your delicate glasses in the top.



EcoBox

This green innovation recycles the final rinsing water to use in the next wash, reducing water consumption.



EcoWash

Our machines come as standard with half-load Eco-Wash technology, helping to save time, energy and money.



Express 50'

Delivering top washing quality in just 50', this program is the ultimate in efficient dishwashing.



Easy Tray

This ingenious little tray allows you to load and unload all your cutlery while also saving space in the machine.



Hygiene

A special filter and a range of hygiene programs help Sharp dishwashers fight harmful bacteria.



IntelliWash

Intelligent sensor technology measures the soil level to auto-optimize cleaning performance.



QuickWash

Cleaning dishes in a 4 place setting capacity dishwasher in 14 minutes.



SteamWash

Making light work of stubborn dishes, Sharp SteamWash cleans baked-on food in a flash.



SuperQuiet

Whisper quiet, this dishwasher can wash in near silence with only 39 dBA sound level.



AquaStop

The flood busting Aquastop hose shuts off the water supply in the event of a leak, limiting damage to your home.



Foldable Lower Racks

Pots and pans can be washed with ease thanks to these foldable lower rack wires.



Foldable Upper & Lower

No need to struggle to get everything in, our machines have adjustable racks to fit in all your dishes, glasses, pots and pans.



10yr Motor Warranty

Our Advanced Inverter Motor delivers superior efficiency and quieter operation, all backed by a 10yr parts warranty.



EcoWash

Provides the independent usage of upper and lower baskets within load options, saves energy and decrease water consumption.



ExtraDry

Provides extra drying with turbo fan for 10-20 minutes (depends on the selected program).



ExtraRinse

Adds an extra rinse step to achieve more hygienic washing. Program duration is increased 5-10 minutes and water consumption is increased 3-4 liter according to the selected program.



ExtraSilent

With less motor speed and more washing time it provides extra silent wash.



ExtraFast

Decreases program duration while increasing water temperature and pressure to ensure higher washing quality in a shorter duration.



ExtraHygiene

Increases water temperature at final rinse step in order to eliminate bacteria and provides maximum hygiene.



EnergySave

A technology that makes the drying process more efficient. Auto Door opens the door of the dishwasher during the drying process automatically and by this way the hot air goes out of the dishwasher by itself.



Hygiene Program



Our special Hygiene programme ensures maximum hygiene with high temperature washing. The special hygiene programme that eliminates **99.9999%** of all bacteria is tested and approved by International German Test Institute of VDE. For further protection, all Sharp dishwashers come fitted as standard with an advanced Antibacterial Filter, helping to protect the family.



AntiBacterial Filter

Red antibacterial filter helps to provide hygiene in order to protect family. Special treatment helps reduce bacterial growth, odours and mould in the filter.



SteamWash Program

In the most appropriate moment the heater increases the water temperature up to around 70°C. Steam is created inside and softens up the soil from pots and pans to fragile glasses for about ten minutes. Dishes are gently sanitized at the same time. After this treatment the dirt is quickly and easily removed. High temperature and directly applied steam ensure perfect hygiene and gentle cleaning for dishes. Steam wash is more hygienic, healthier and clean perfectly every kind of soil.

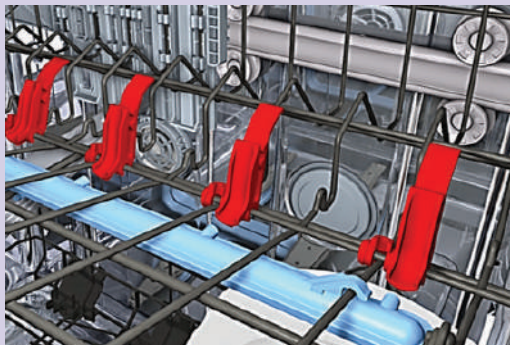

AquaGlide

AquaGlide provides deep precision multidirectional targeted cleaning with pin-point accuracy. The spray can be directed upward for effective wash of glasses and baby bottles or downward to achieve extra strength wash in the dishes below.

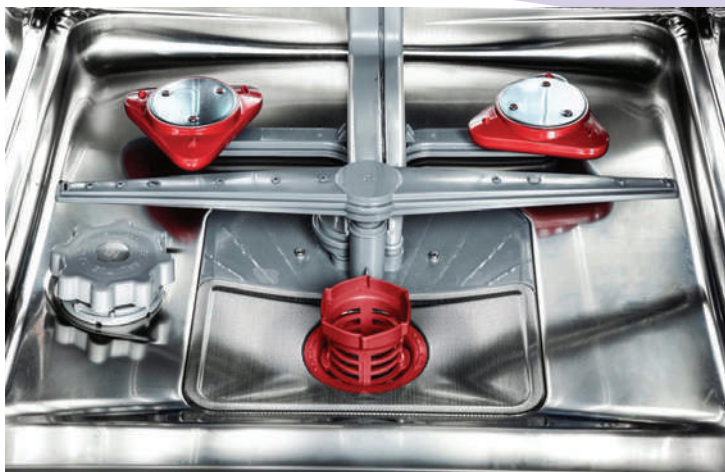

WaterBlade

WaterBlade technology delivers a truly immersive powerful clean with two additional spray arms that can work both together with the main spray arm or individually.



Advanced Inverter Motor

Superior efficiency, reduced noise levels and a longer lifetime backed by a **10 year motor warranty** are all delivered with our **Advanced Inverter Motor** making doing the laundry a pleasure rather than a chore.

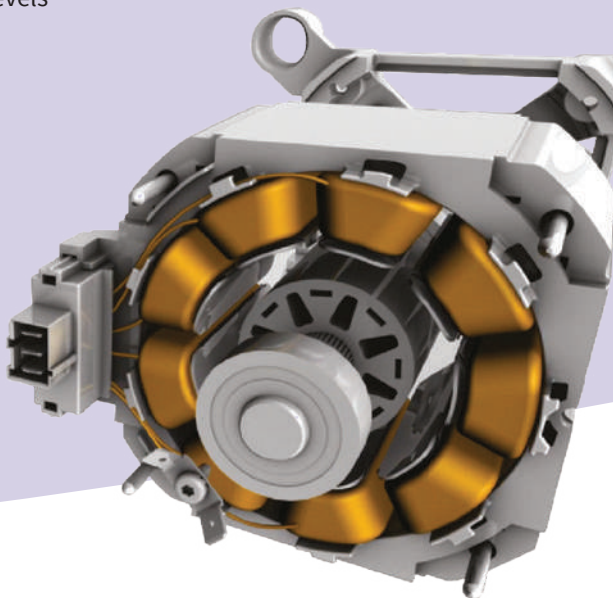

Lower energy consumption



Increased reliability



Reduced noise



Longer lifetime



Lower water consumption



10 year Warranty Conditions

- ✓ 10 year warranty on the Advanced Inverter Motor
- ✓ Customer warranty registration within 30 days of purchase
- ✓ Terms and conditions apply
- ✓ Claims due to customer misuse are excluded

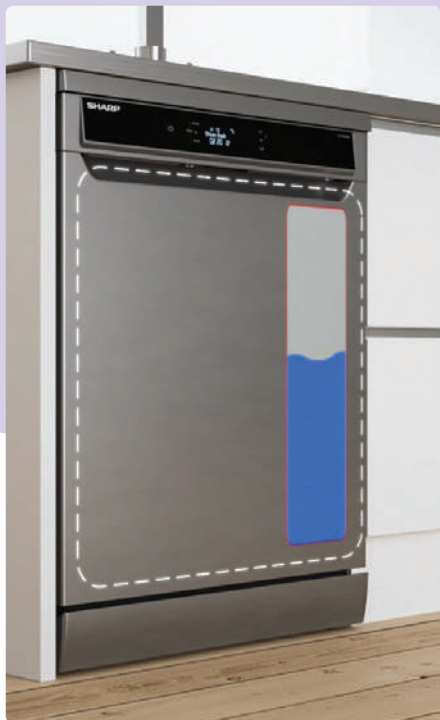

EcoBox

EcoBox technology delivers the Worlds Lowest Water Consumption for 14 place settings with just 5.4 liters of water use.

The working principle of EcoBox is based on getting the last clean cycle rinse water, filtering it to avoid any particles and saving it in an isolated box to use in the first cycle of the next wash.



AutoDoor

AutoDoor is a technology that increases drying efficiency by opening the door of the dishwasher at the end of the cycle to release hot air.”

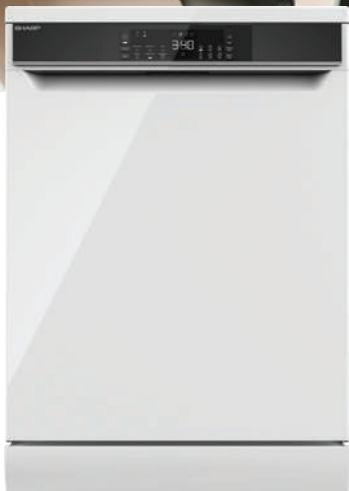

Dual Pro Wash

By using Advanced Inverter Motor technology on the circulation pump, Dual ProWash Dishwashers can tackle the dirtiest of pans in the bottom, whilst taking care of your delicate glasses in the top basket. Variable pump pressure helps to minimise noise levels, helping to maintain peace and quiet in the kitchen.



IntelliWash

IntelliWash uses smart technology to intelligently measure the levels of turbidity in the water, providing maximum performance by applying the optimum washing temperature and time according to the amount of soil.

Turbidity



Water Temperature



Program Time



Wash Performance





39dBA Sharp SuperQuiet *Dishwasher*

Whisper-quiet, our Super Quiet dishwashers can operate at a barely audible 39dBA.

Circulation pump Advanced Inverter Motor technology, a specially designed cabinet and advanced sound insulation allow our dishwashers to perform without making a noise.

Drying Systems

2 different types of drying systems on dishwashers;



Active Drying

Better drying performance with the help of the big size and condensation channels places inside of the drying unit. It improves the drying efficiency up to %10 better than standard drying.

Turbo Drying

Best drying performance with the help of electrical fan motor at the end of the condensation unit. It helps the moist air to escape with the %18-19 better drying efficiency.

* The values above are the values obtained under laboratory conditions and with the same algorithm



AntiBacterial Filter

of your Sharp Dishwasher



Clean dishes and utensils are important to family health. Over time, bacteria can build up from previous cycles.



All SHARP dishwashers come fitted as standard with an advanced Antibacterial Filter, helping to protect the family and ensuring maximum hygiene. Antibacterial Filter effectively reduces bacterial growth on the filter (%99,9*).



Antibacterial Filter keeps your dishwasher clean and helps to reduce odours left behind from residues.

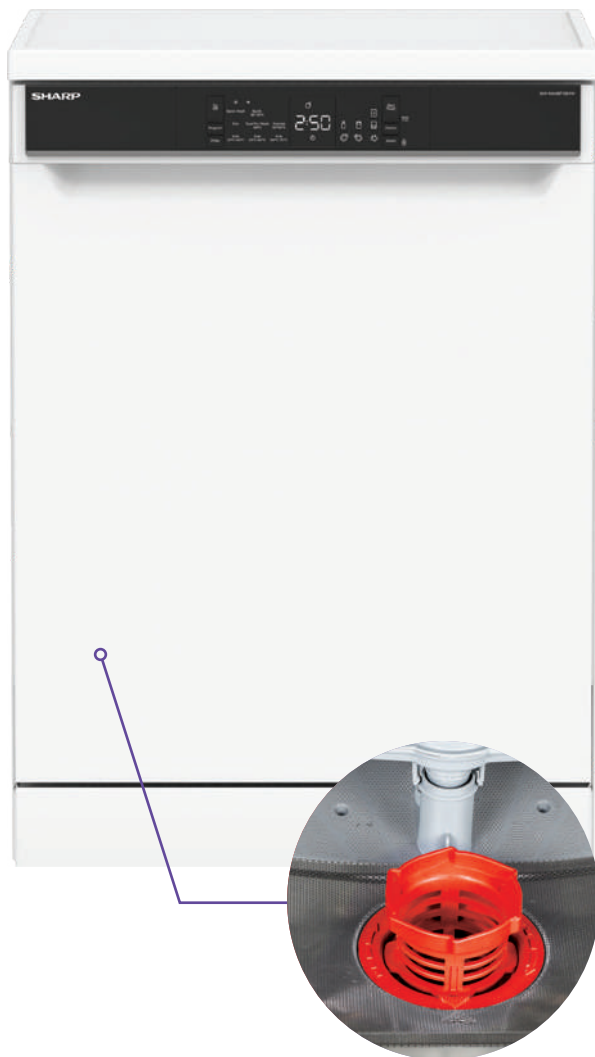

*According to accredited test laboratory report, filter eliminates the specific bacteria (Staphylococcus aureus, Escherichia coli).

Antibacterial filter contains biocidal active substance as zinc pyrithione (CAS No: 13463-41-7).

Basket Options



Universal Cutlery Basket



Sliding Cutlery Basket



Fixed Cutlery Basket

3rd Rack Options



Easy Tray



Eco Tray



Built-in
60 cm Range

QW-NI13I49EX



<i>Capacity</i>	13 PS
<i>Program Number</i>	4 programmes
<i>Cabinet Type</i>	60cm
<i>Energy Label</i>	E
<i>Water Consumption</i>	12 liters
<i>Antibacterial Filter</i>	Yes
<i>Sound Level (dBA)</i>	49 dBA
<i>Drying System</i>	Active Drying
<i>Number of Rack</i>	2 racks
<i>Overflow & Leakage Protection</i>	Yes
<i>Delay Timer</i>	Yes (3-6-9 hr)

<i>Half Load Option</i>	YES (1 Mode)
<i>Express 50</i>	YES

QW-NI14I47EX



<i>Capacity</i>	13 PS
<i>Program Number</i>	5 programmes
<i>Cabinet Type</i>	60cm
<i>Energy Label</i>	E
<i>Water Consumption</i>	12 liters
<i>Antibacterial Filter</i>	Yes
<i>Sound Level (dBA)</i>	47 dBA
<i>Drying System</i>	Active Drying
<i>Number of Rack</i>	2 racks
<i>Overflow & Leakage Protection</i>	Yes
<i>Delay Timer</i>	Yes (3-6-9 hr)

<i>Half Load Option</i>	YES (1 Mode)
<i>Express 50</i>	YES

QW-NI1EI45EX



<i>Capacity</i>	15 PS
<i>Program Number</i>	6 programmes
<i>Cabinet Type</i>	60cm
<i>Energy Label</i>	E
<i>Water Consumption</i>	9 liters
<i>Antibacterial Filter</i>	Yes
<i>Sound Level (dBA)</i>	45 dBA
<i>Drying System</i>	Turbo Drying
<i>Number of Rack</i>	3 racks
<i>Overflow & Leakage Protection</i>	Yes
<i>Delay Timer</i>	Yes (1-2-3-...-19hr)

<i>Display</i>	White LED
<i>Half Load Option</i>	YES (1 Mode)
<i>Express 50</i>	YES
<i>HygieneWash</i>	YES

QW-NI22I45EX



<i>Capacity</i>	15 PS
<i>Program Number</i>	8 programmes
<i>Cabinet Type</i>	60cm
<i>Energy Label</i>	E
<i>Water Consumption</i>	9 liters
<i>Antibacterial Filter</i>	Yes
<i>Sound Level (dBA)</i>	45 dBA
<i>Drying System</i>	Turbo Drying
<i>Number of Rack</i>	3 racks (Easy Tray)
<i>Overflow & Leakage Protection</i>	Yes
<i>Delay Timer</i>	Yes (1-2-3-...-19hr)

<i>Display</i>	White LED
<i>Half Load Option</i>	YES (3 Modes)
<i>Interior LED lightning</i>	YES
<i>Express 50</i>	YES

QW-NI27I47DX



<i>Capacity</i>	15 PS
<i>Program Number</i>	7 programmes
<i>Cabinet Type</i>	60cm
<i>Energy Label</i>	D
<i>Water Consumption</i>	9 liters
<i>Antibacterial Filter</i>	Yes
<i>Sound Level (dBA)</i>	47 dBA
<i>Drying System</i>	Turbo Drying
<i>Number of Rack</i>	3 racks (Easy Tray)
<i>Overflow & Leakage Protection</i>	Yes
<i>Delay Timer</i>	Yes (1-2-3-...-19hr)

<i>Display</i>	White LED
<i>ExtraSilent & ExtraDry</i>	YES
<i>Half Load Option</i>	YES (3 Modes)
<i>IntelliWash</i>	YES
<i>Interior LED lightning</i>	YES
<i>Express 50</i>	YES
<i>DualPro Wash</i>	YES
<i>Steam Wash</i>	YES
<i>Advanced Inverter Type</i>	YES

QW-NI54I44DX



**NEW
PRODUCT**

<i>Capacity</i>	15 PS
<i>Program Number</i>	9 programmes
<i>Cabinet Type</i>	60cm
<i>Energy Label</i>	D
<i>Water Consumption</i>	9 liters
<i>Antibacterial Filter</i>	Yes
<i>Sound Level (dBA)</i>	44 dBA
<i>Drying System</i>	Turbo Drying
<i>Number of Rack</i>	3 racks (Easy Tray)
<i>Overflow & Leakage Protection</i>	Yes
<i>Delay Timer</i>	Yes (1-2-3-...-19hr)

<i>Display</i>	White LED
<i>ExtraSilent & ExtraDry</i>	YES
<i>Half Load Option</i>	YES (3 Modes)
<i>IntelliWash</i>	YES
<i>DualPro Wash</i>	YES
<i>Interior LED lightning</i>	YES
<i>QuickWash</i>	YES
<i>Express 50</i>	YES
<i>AutoDoor</i>	YES
<i>HygieneWash</i>	YES
<i>Advanced Inverter Type</i>	YES



Built-in
45 cm Range

QW-NS12I49EX



<i>Capacity</i>	10 PS
<i>Program Number</i>	3 programmes
<i>Cabinet Type</i>	45cm
<i>Energy Label</i>	E
<i>Water Consumption</i>	11 liters
<i>Antibacterial Filter</i>	Yes
<i>Sound Level (dBA)</i>	49 dBA
<i>Drying System</i>	Active Drying
<i>Number of Rack</i>	2 racks
<i>Overflow & Leakage Protection</i>	Yes
<i>Delay Timer</i>	Yes (3-6-9 hr)

<i>Half Load Option</i>	YES (1 Mode)
<i>Express 50</i>	YES

QW-NS14I49EX



**NEW
PRODUCT**

<i>Capacity</i>	10 PS	<i>Half Load Option</i>	YES (1 Mode)
<i>Program Number</i>	5 programmes	<i>Express 50</i>	YES
<i>Cabinet Type</i>	45cm		
<i>Energy Label</i>	E		
<i>Water Consumption</i>	11 liters		
<i>Antibacterial Filter</i>	Yes		
<i>Sound Level (dBA)</i>	49 dBA		
<i>Drying System</i>	Active Drying		
<i>Number of Rack</i>	2 racks		
<i>Overflow & Leakage Protection</i>	Yes		
<i>Delay Timer</i>	Yes (3-6-9 hr)		

QW-NS1GI47EX



<i>Capacity</i>	10 PS
<i>Program Number</i>	8 programmes
<i>Cabinet Type</i>	45cm
<i>Energy Label</i>	E
<i>Water Consumption</i>	9 liters
<i>Antibacterial Filter</i>	Yes
<i>Sound Level (dBA)</i>	47 dBA
<i>Drying System</i>	Turbo Drying
<i>Number of Rack</i>	3 racks (Easy Tray)
<i>Overflow & Leakage Protection</i>	Yes
<i>Delay Timer</i>	Yes (1-2-3-...-19hr)

<i>Display</i>	White LED
<i>Half Load Option</i>	YES (1 Mode)
<i>Express 50</i>	YES
<i>HygieneWash</i>	YES

SHARP



Semi-integrated
60 cm Range

QW-NA24S42DI

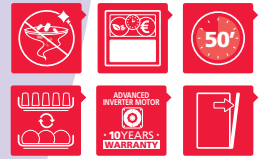

<i>Capacity</i>	15 PS
<i>Program Number</i>	8 programmes
<i>Cabinet Type</i>	60cm
<i>Energy Label</i>	D
<i>Water Consumption</i>	9 liters
<i>Antibacterial Filter</i>	YES
<i>Sound Level (dBA)</i>	42 dBA
<i>Drying System</i>	Turbo Drying
<i>Number of Rack</i>	3 racks (Easy Tray)
<i>Overflow & Leakage Protection</i>	YES
<i>Delay Timer</i>	Yes (1-2-3-...-24hr)

<i>Display</i>	White LED
<i>Half Load Option</i>	YES (3 Modes)
<i>IntelliWash</i>	YES
<i>DualPro Wash</i>	YES
<i>QuickWash</i>	YES
<i>Express 50</i>	YES
<i>AutoDoor</i>	YES
<i>Advanced Inverter Type</i>	YES



Semi-integrated
45 cm Range

QW-NS23S47EI



<i>Capacity</i>	10 PS
<i>Program Number</i>	8 programmes
<i>Cabinet Type</i>	60cm
<i>Energy Label</i>	E
<i>Water Consumption</i>	9 liters
<i>Antibacterial Filter</i>	YES
<i>Sound Level (dBA)</i>	47 dBA
<i>Drying System</i>	Active Drying
<i>Number of Rack</i>	2 racks
<i>Overflow & Leakage Protection</i>	YES
<i>Delay Timer</i>	Yes (1-2-3-...-24hr)

<i>Display</i>	White LED
<i>Half Load Option</i>	YES (3 Modes)
<i>IntelliWash</i>	YES
<i>Express 50</i>	YES



Built-in Washing Machines

Premium Features

Summary



ThermoJet

An eco-champion, ThermoJet by Sharp delivers ultra low energy and water use with fast washing times.



DoubleJet

Twin nozzle technology fires water and detergent to the center of the drum, decreasing energy and water use.



WaveCabinet

Special Wave design on the cabinet provides greater stability, lowering vibration and noise.



AquaBall

Standard across the Sharp range, AquaBall is a special valve mounted between the tub and drain pump which prevents detergent waste, significantly reducing laundry costs.



AllergySmart

Endorsed by Allergy UK, Allergy Smart program is designed to combat commonly found allergens and bacteria.



Aquastop

The flood busting Aquastop hose shuts off the water supply in the event of a leak, limiting damage to your home.



StainTypeSelection

By tackling up to 22 different types of common stains, this technology helps ensure perfect washing results.



BubbleDrum

The specially design drum pattern helps look after delicate clothes even at higher spin speeds.



Advanced Inverter Motor

Superior efficiency, reduced noise levels and a longer lifetime are all delivered with our Advanced Inverter Motor.



EcoLogic

Sharp machines come as standard with half-load Eco-Logic technology, helping to save time, energy and money.



NightProgram

Helping you get a good night sleep, this clever program delays the last spin by up to 10 hours.



Memories

Having found your ideal wash settings Memories lets you save it at the push of the button for the next time you need it.



39 dBA Most Silent Wash

Operating at near whisper quiet levels, this record breaking SuperQuiet dishwasher gets on with your dishes without making a noise about it.



AntiBacterial Material

Sharp helps to safeguard you & your family. Specially coated material on our washing machines is designed to offer protection from harmful bacteria.



Connectivity

Wifi connected SHARP Smart Washing Machines allow remote control operation and programmeme monitoring via a handy app.



IntelliDos

The Load and Dosage Sensor calculates the wash load and automatically adjusts the time and required detergent.



Drum Cleaning

Say goodbye to those strange laundry smells. This high temperature wash will kill bacteria and leave you drum smelling fresh and looking clean.



Eco Timer

Off peak energy tariffs make things cheaper to run. The Eco Timer lets you tell the machine exactly when you want it to be active saving you on energy bills.



Finish Time

Don't let the laundry dictate your day, set a time you want it to finish and the machine will start with that end time in mind, meaning it fits into your timetable, not the other way round.



Allergy Smart

Special Algorithm provides complete hygiene %99,9
Reduce common allergens and bacteria

Allergens

House Dust Mite
Cat allergen
Dog allergen
Live House Dust Mite
Pollen
Fungi

Bacterias

Escherichia coli
Enterococcus faecalis
Staphylococcus aureus
Staphylococcus saprop



Awarded «Seal of Approval» by Allergy UK, which is a reputable foundation that had been established in order to support approximately 21 million allergy patients in England.



Advanced Inverter Motor

Superior efficiency, reduced noise levels and a longer lifetime backed by a **10 year motor warranty** are all delivered with our **Advanced Inverter Motor** making doing the laundry a pleasure rather than a chore.

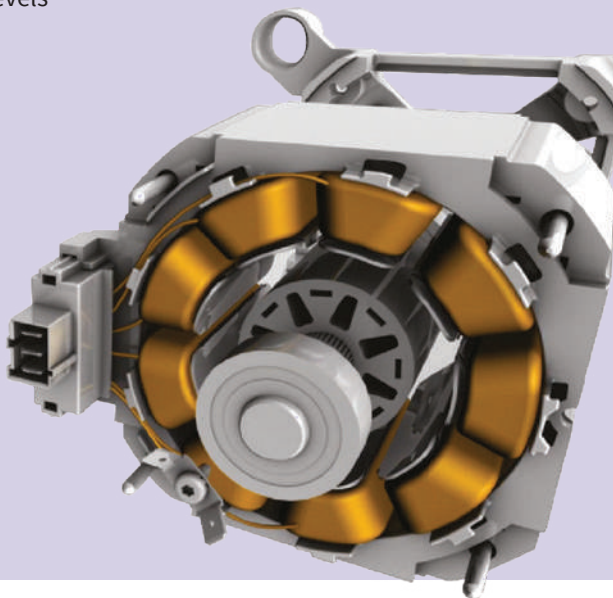

- ✓ Customer warranty registration within 30 days of purchase
- ✓ Terms and conditions apply



Lower energy consumption



Increased reliability



Reduced noise



10 YEARS WARRANTY

Longer lifetime



Lower water consumption



Eco Logic



Available on all Sharp Washing Machines, a sophisticated eco-logic system detects when the machine is half-loaded, so energy consumption can be automatically reduced by up to 50% and water consumption and programme durations are decreased, saving time, energy and money.



Aquaball



Standard across the Sharp range, Aquaball is a special valve mounted between the tub and drain pump which prevents detergent waste, significantly reducing laundry costs.

Without it about **30%** of powder goes directly to pump.

With Aquaball installed almost **100%** of powder remains in tub.



Steam Function

of your Sharp Washing Machine



Hygienic!



Refresh!



Gentle Cleaning!



For which programs can we use Steam option?

✓ If the model has, Steam option can be active in all programs.

What is the algorithm of Steam option?

✓ There is a steam session at the end of program.

✓ After Steam selection, there is 26 minutes program duration increasing. In this process, steam is obtained intermittently by activating the heater. Heater is active for the 4.5 minutes.

✓ There is no change in the washing temperature. There is only temperature increasing at the end of the program.

Applicable for T Series washing machine models



Steam generation with existing heater

How can we obtain more hygienic laundry with Steam?

✓ Steam offers more hygienic washing and reduction of bacteria with the high temperature. Usage of Steam with Allergy Smart program will increase this hygienic effect.

What's more with Steam?

✓ In addition to the being hygienic, Steam also provides easy ironing laundry. Moreover, it is refreshing.



Washing Machines

Built-in

ES-NIB7141WD



<i>Capacity</i>	7 kg (49 Liter)
<i>Spin Speed</i>	1400 rpm
<i>Cabinet Type</i>	Standard
<i>Energy Label</i>	D
<i>Fast Program</i>	15 min. rapid wash
<i>Program Number</i>	15 programs
<i>Anti-Allergy</i>	Allergy Smart Prg.
<i>Delay Timer</i>	Up to 23 hours
<i>Others - 1</i>	Automatic Overflow Protection
<i>Others - 2</i>	Ecologic System

<i>Button 1</i>	Easy Ironing
<i>Button 2</i>	Steam
<i>Button 3</i>	Temperature
<i>Button 4</i>	Spin Speed
<i>Button 5</i>	Delay Timer
<i>Display</i>	White LED
<i>Door Dia.</i>	Big Door – 47 cm
<i>Wave Cabinet</i>	YES
<i>Buzzer</i>	YES
<i>Liquid Det. Apparatus</i>	YES
<i>Motor Type</i>	Universal
<i>Steam</i>	YES

ES-NIB8141WD



<i>Capacity</i>	8 kg (51 Liter)
<i>Spin Speed</i>	1400 rpm
<i>Cabinet Type</i>	Standard
<i>Energy Label</i>	D
<i>Fast Program</i>	15 min. rapid wash
<i>Program Number</i>	15 programs
<i>Anti-Allergy</i>	Allergy Smart Prg.
<i>Delay Timer</i>	Up to 23 hours
<i>Others - 1</i>	Automatic Overflow Protection
<i>Others - 2</i>	Ecologic System

<i>Button 1</i>	Easy Ironing
<i>Button 2</i>	Steam
<i>Button 3</i>	Temperature
<i>Button 4</i>	Spin Speed
<i>Button 5</i>	Delay Timer
<i>Display</i>	White LED
<i>Door Dia.</i>	Big Door - 47 cm
<i>Wave Cabinet</i>	YES
<i>Buzzer</i>	YES
<i>Liquid Det. Apparatus</i>	YES
<i>Motor Type</i>	Universal
<i>Steam</i>	YES

ES-NIB714BWC



Capacity	7 kg (49 Liter)
Spin Speed	1400 rpm
Cabinet Type	Standard
Energy Label	C
Fast Program	15 min. rapid wash
Program Number	15 programs
Anti-Allergy	Allergy Smart Prg.
Delay Timer	Up to 23 hours
Others - 1	Automatic Overflow Protection
Others - 2	Ecologic System

Button 1	Easy Ironing
Button 2	Steam
Button 3	Temperature
Button 4	Spin Speed
Button 5	Delay Timer
Display	White LED
Door Dia.	Big Door – 47 cm
Wave Cabinet	YES
Buzzer	YES
Liquid Det. Apparatus	YES
Motor Type	AIM
Steam	YES

ES-NIB814BWB



<i>Capacity</i>	8 kg (51 Liter)
<i>Spin Speed</i>	1400 rpm
<i>Cabinet Type</i>	Standard
<i>Energy Label</i>	B
<i>Fast Program</i>	15 min. rapid wash
<i>Program Number</i>	15 programs
<i>Anti-Allergy</i>	Allergy Smart Prg.
<i>Delay Timer</i>	Up to 23 hours
<i>Others - 1</i>	Automatic Overflow Protection
<i>Others - 2</i>	Ecologic System

<i>Button 1</i>	Easy Ironing
<i>Button 2</i>	Steam
<i>Button 3</i>	Temperature
<i>Button 4</i>	Spin Speed
<i>Button 5</i>	Delay Timer
<i>Display</i>	White LED
<i>Door Dia.</i>	Big Door - 47 cm
<i>Wave Cabinet</i>	YES
<i>Buzzer</i>	YES
<i>Liquid Det. Apparatus</i>	YES
<i>Motor Type</i>	AIM
<i>Steam</i>	YES

SHARP

Be Original.