

Home Appliances

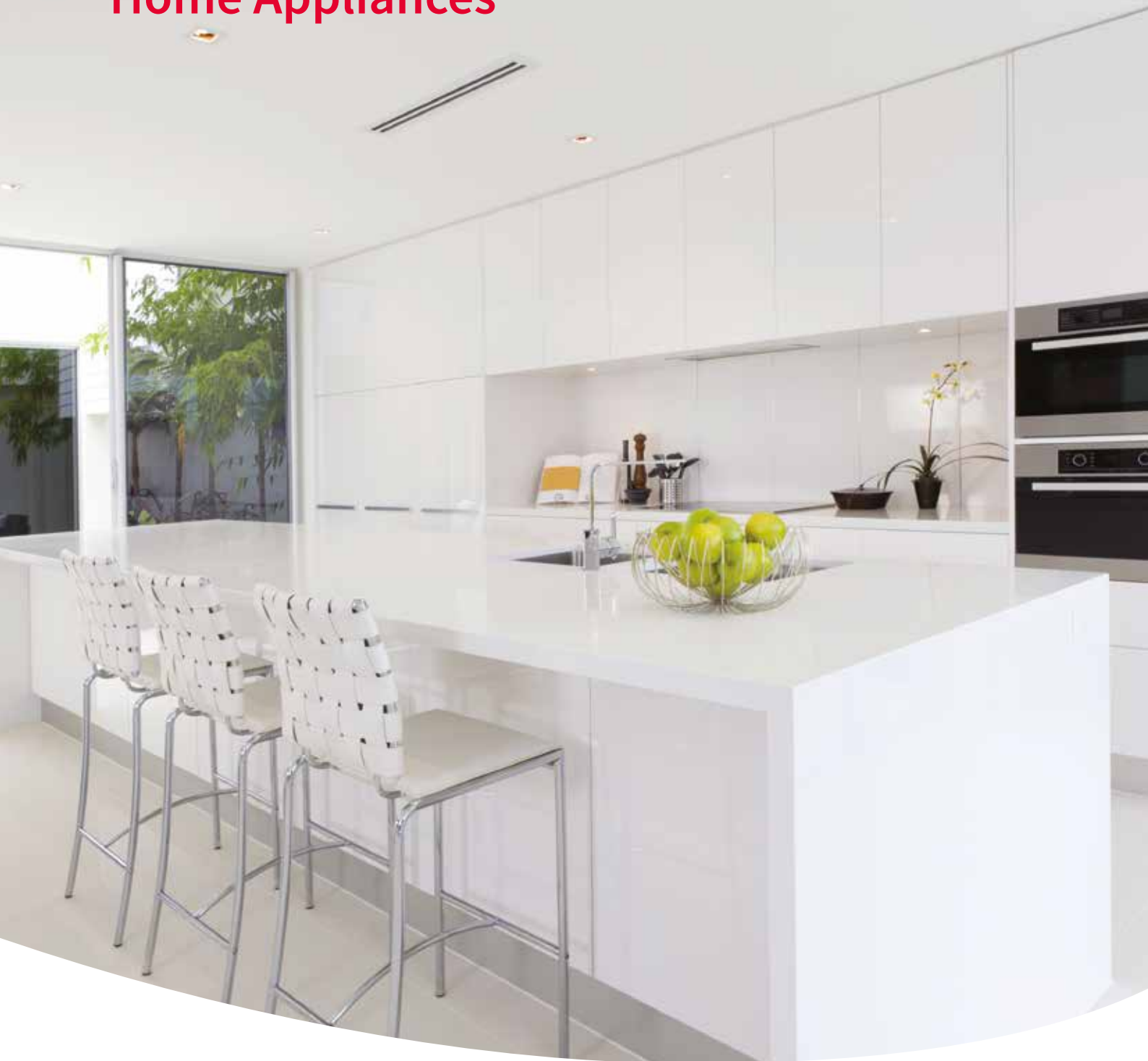

Built-in
2018 Range

SHARP
Be Original.

BUILT-IN RANGE

With Sharp, it's easy to find the perfect product match for every home. Made to complement and enhance the overall design of a kitchen, our built-in cooking, cooling and dishwasher ranges come in a wider variety of sizes and styles, enabling us to provide personalized support for more lifestyles and household routines. Whatever their design, size or capacity, all our built-in products ensure an exceptional standard of energy efficiency as well as discreet and ultra-quiet operation.

Sharp Original Technology

Our pledge to "Be Original." has inspired us to diversify and challenge the norm with products that can make real differences to life at home. Offering a technology feature for every need and every occasion, our products lighten the load, enabling everyday household tasks to be completed in minutes.

Whilst our built-in refrigeration is designed to maximize storage space with innovative shelving, our ovens and hobs provide a whole host of time-saving features, allowing cooks in a hurry to prepare dishes at the touch of a control.

For the post-meal clean up, we also offer faster, self-cleaning oven features, automatic steam sensors for our wall mounted cooker hoods, and 14 minute dishwasher cycles to sprint through the washing up.



MAXIMIZE EFFICIENCY
AND STORAGE SPACE
WITH OUR BUILT-IN
FRIDGE/FREEZER RANGE



Key Features / Fridge



OdourNeutral

No odour transfer between the fridge and freezer compartments



Gentle AirFlow

Advanced air distribution control helps prevent food from drying

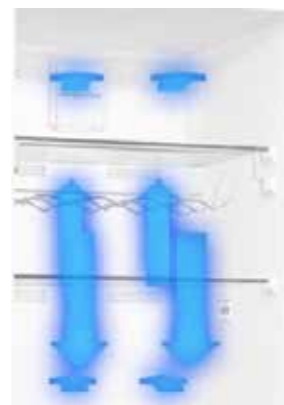

Dual Control

Electronic control where you can adjust the temperature of your fridge and freezer compartments independently. Consumer can control the fridge and freezer compartments separately



E-filter technology

E-filter technology helps to remove ethylene gas (a bio-product released naturally from fresh foods) and unpleasant odors from the crisper. In this way, food stays fresh for a longer time.



Key Features / Fridge



Fruit&VegZone

Ideal for storing fruit and vegetables keeping them fresh and crisp



Opti Fresh

Allows adjustment of humidity levels to help preserve fruit and vegetables



AdaptiLift

Easily adjust the position of the door trays to suit your needs



TwinLED

Brighter compartment and better food visibility



SJ-L1300E00X / SJ-L2300E00X / SJ-L2300E01X Fridge



MODEL NAME		
Energy Class		A+ / A++
Volume Total (net)	lt	300
Volume Refrigerator Total (net)	lt	300
Volume Freezer (net)	lt	-
Noise Emission	dB(A)	39
Product dimensions (WxDxH)	mm	540x545x1770
Cooling Type		Direct Cooling
Wine Rack		•
Adapti Lift		•
Sliding Hinge		Optional
Odour Free		•
Control Type		Electronic
Opti Fresh		•
Fruit&Veg Zone		•

*All models include Door on Door hinge by default.

SJ-S1197E00X / SJ-S2197E00X / SJ-S2197E01X Fridge



MODEL NAME		
Energy Class		A+ / A++
Volume Total (net)	lt	197
Volume Refrigerator Total (net)	lt	-
Volume Freezer (net)	lt	197
Noise Emission	dB(A)	41
Product dimensions (WxDxH)	mm	540x545x1770
Cooling Type		No frost
Wine Rack		•
Adapti Lift		-
Sliding Hinge		Optional
Odour Free		•
Control Type		Electronic
Opti Fresh		-
Fruit&Veg Zone		-

*All models include Door on Door hinge by default.

SJ-B1237M00X / SJ-B2237M01X Fridge



MODEL NAME		
Energy Class		A+ / A++
Volume Total (net)	lt	243
Volume Refrigerator Total (net)	lt	180
Volume Freezer (net)	lt	63
Noise Emission	dB(A)	41
Product dimensions (WxDxH)	mm	540x545x1770
Cooling Type		No frost
Wine Rack		•
Adapti Lift		•
Sliding Hinge		Optional
Odour Free		•
Control Type		Mechanic
Opti Fresh		•
Fruit&Veg Zone		•

*All models include Door on Door hinge by default.

SJ-B1243M00X / SJ-B1243M01X Fridge



MODEL NAME		
Energy Class		A+
Volume Total (net)	lt	251
Volume Refrigerator Total (net)	lt	181
Volume Freezer (net)	lt	70
Noise Emission	dB(A)	38
Product dimensions (WxDxH)	mm	540x545x1770
Cooling Type		Static
Wine Rack		•
Adapti Lift		•
Sliding Hinge		Optional
Odour Free		•
Control Type		Mechanic
Opti Fresh		•
Fruit&Veg Zone		•

*All models include Door on Door hinge by default.

SJ-B1227M00X Fridge



MODEL NAME		
Energy Class		A+
Volume Total (net)	lt	233
Volume Refrigerator Total (net)	lt	147
Volume Freezer (net)	lt	86
Noise Emission	dB(A)	43
Product dimensions (WxDxH)	mm	540x545x1770
Cooling Type		No frost
Wine Rack		•
Adapti Lift		•
Sliding Hinge		-
Odour Free		•
Control Type		Mechanic
Opti Fresh		•
Fruit&Veg Zone		•

*All models include Door on Door hinge by default.

SJ-T1214M0X / SJ-T2214M0X / SJ-T2214M1X Fridge



MODEL NAME		
Energy Class		A+ / A++
Volume Total (net)	lt	214
Volume Refrigerator Total (net)	lt	176
Volume Freezer (net)	lt	38
Noise Emission	dB(A)	40
Product dimensions (WxDxH)	mm	540x545x1445
Cooling Type		Direct Cooling
Wine Rack		•
Adapti Lift		-
Sliding Hinge		Optional
Odour Free		-
Control Type		Mechanic
Opti Fresh		-
Fruit&Veg Zone		•

*All models include Door on Door hinge by default.

SJ-L1192M0X Fridge



MODEL NAME

Energy Class		A+
Volume Total (net)	lt	192
Volume Refrigerator Total (net)	lt	175
Volume Freezer (net)	lt	17
Noise Emission	dB(A)	42
Product dimensions (WxDxH)	mm	540x545x1225
Cooling Type		Direct Cooling
Wine Rack		•
Adapti Lift		-
Sliding Hinge		-
Odour Free		-
Control Type		Mechanic
Opti Fresh		-
Fruit&Veg Zone		•

*All models include Door on Door hinge by default.

SJ-L2204M0X Fridge



MODEL NAME

Energy Class		A++
Volume Total (net)	lt	204
Volume Refrigerator Total (net)	lt	204
Volume Freezer (net)	lt	-
Noise Emission	dB(A)	39
Product dimensions (WxDxH)	mm	540x545x1225
Cooling Type		Direct Cooling
Wine Rack		•
Adapti Lift		•
Sliding Hinge		-
Odour Free		-
Control Type		Mechanic
Opti Fresh		-
Fruit&Veg Zone		•

*All models include Door on Door hinge by default.

SJ-L2160M0X Fridge



MODEL NAME

Energy Class		A++
Volume Total (net)	lt	160
Volume Refrigerator Total (net)	lt	160
Volume Freezer (net)	lt	-
Noise Emission	dB(A)	41
Product dimensions (WxDxH)	mm	540x545x1020
Cooling Type		Direct Cooling
Wine Rack		-
Adapti Lift		-
Sliding Hinge		-
Odour Free		-
Control Type		Mechanic
Opti Fresh		-
Fruit&Veg Zone		•

*All models include Door on Door hinge by default.

SJ-L1134M0X / SJ-L2134M0X / SJ-L2134M1X Fridge



MODEL NAME

Energy Class		A+ / A++
Volume Total (net)	lt	134
Volume Refrigerator Total (net)	lt	134
Volume Freezer (net)	lt	-
Noise Emission	dB(A)	39
Product dimensions (WxDxH)	mm	540x545x875
Cooling Type		Direct Cooling
Wine Rack		-
Adapti Lift		-
Sliding Hinge		Optional
Odour Free		-
Control Type		Mechanic
Opti Fresh		-
Fruit&Veg Zone		•

*All models include Door on Door hinge by default.

SJ-S1099M0X / SJ-S1099M1X Fridge



MODEL NAME		
Energy Class		A+
Volume Total (net)	lt	99
Volume Refrigerator Total (net)	lt	-
Volume Freezer (net)	lt	99
Noise Emission	dB(A)	39
Product dimensions (WxDxH)	mm	540x545x875
Cooling Type		Direct Cooling
Wine Rack		-
Adapti Lift		-
Sliding Hinge		Optional
Odour Free		-
Control Type		Mechanic
Opti Fresh		-
Fruit&Veg Zone		-

*All models include Door on Door hinge by default.

SJ-L1123M1X / SJ-L2123M1X Fridge



MODEL NAME		
Energy Class		A+ / A++
Volume Total (net)	lt	123
Volume Refrigerator Total (net)	lt	106
Volume Freezer (net)	lt	17
Noise Emission	dB(A)	41
Product dimensions (WxDxH)	mm	540x545x875
Cooling Type		Direct Cooling
Wine Rack		-
Adapti Lift		-
Sliding Hinge		Optional
Odour Free		-
Control Type		Mechanic
Opti Fresh		-
Fruit&Veg Zone		-

*All models include Door on Door hinge by default.

Installation / Fridge



SJ-L1123M1X / SJ-L2123M1X
 SJ-S1099M0X / SJ-S1099M1X
 SJ-L1134M0X
 SJ-L2134M0X / SJ-L2134M1X

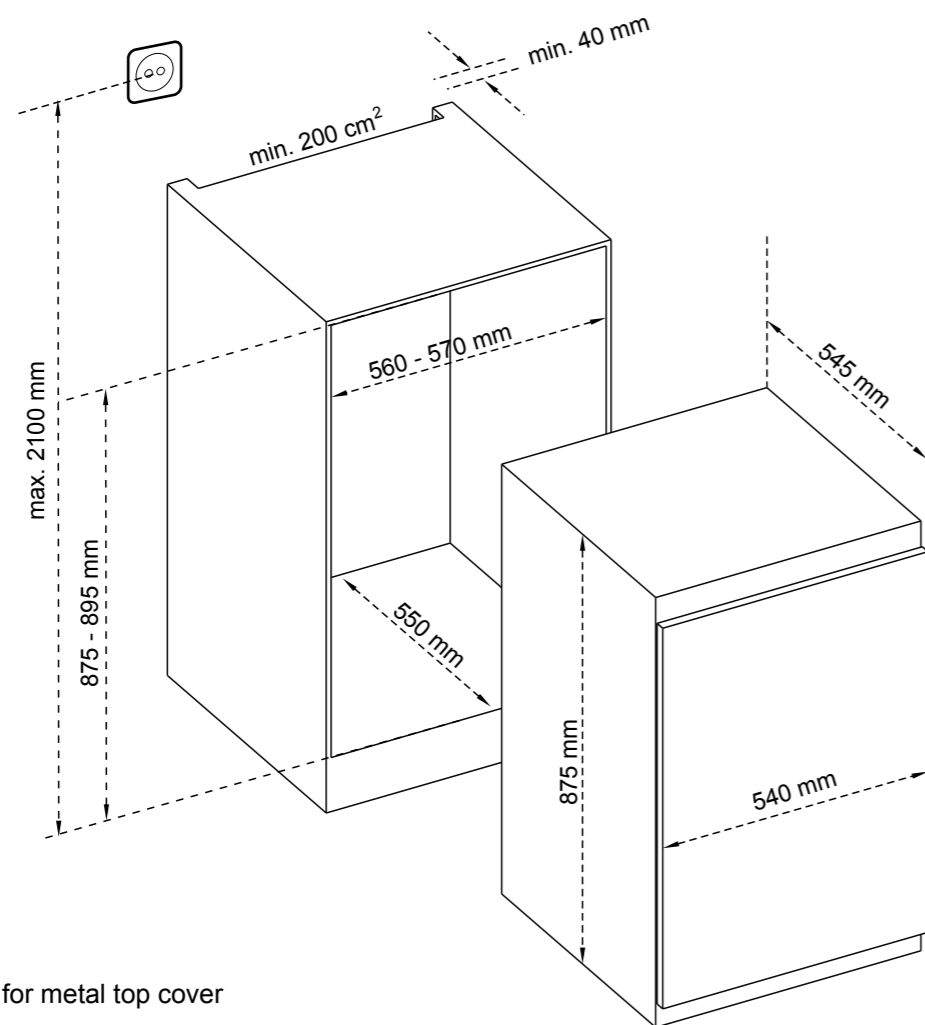

* 875 - 883 for metal top cover

Installation / Fridge



SJ-L2160M0X

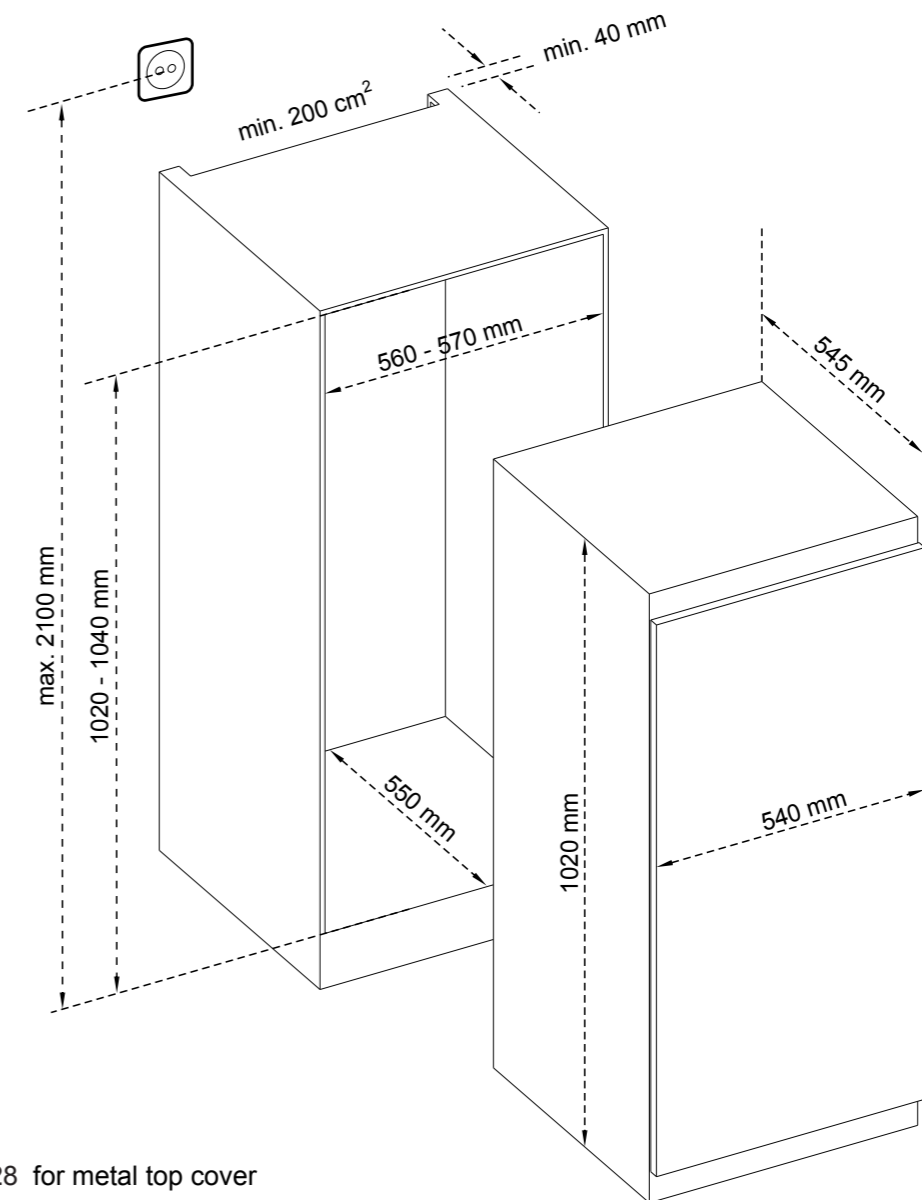

* 1020 - 1028 for metal top cover

Installation / Fridge



SJ-L1192M0X
SJ-L2204M0X

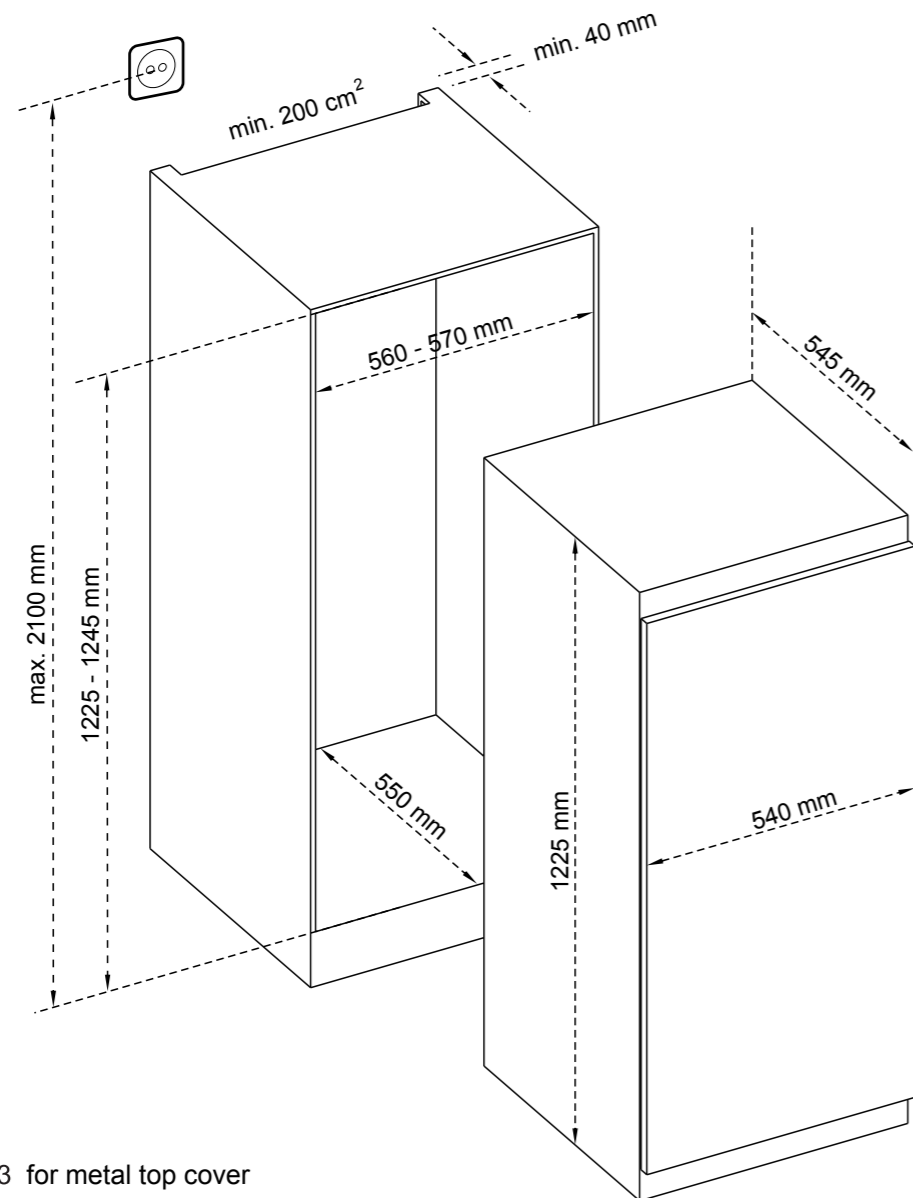

* 1225 - 1233 for metal top cover

Installation / Fridge



SJ-S1197E00X
SJ-S2197E00X / SJ-S1197E01X
SJ-L1300E00X
SJ-L2300E00X / SJ-L2300E01X

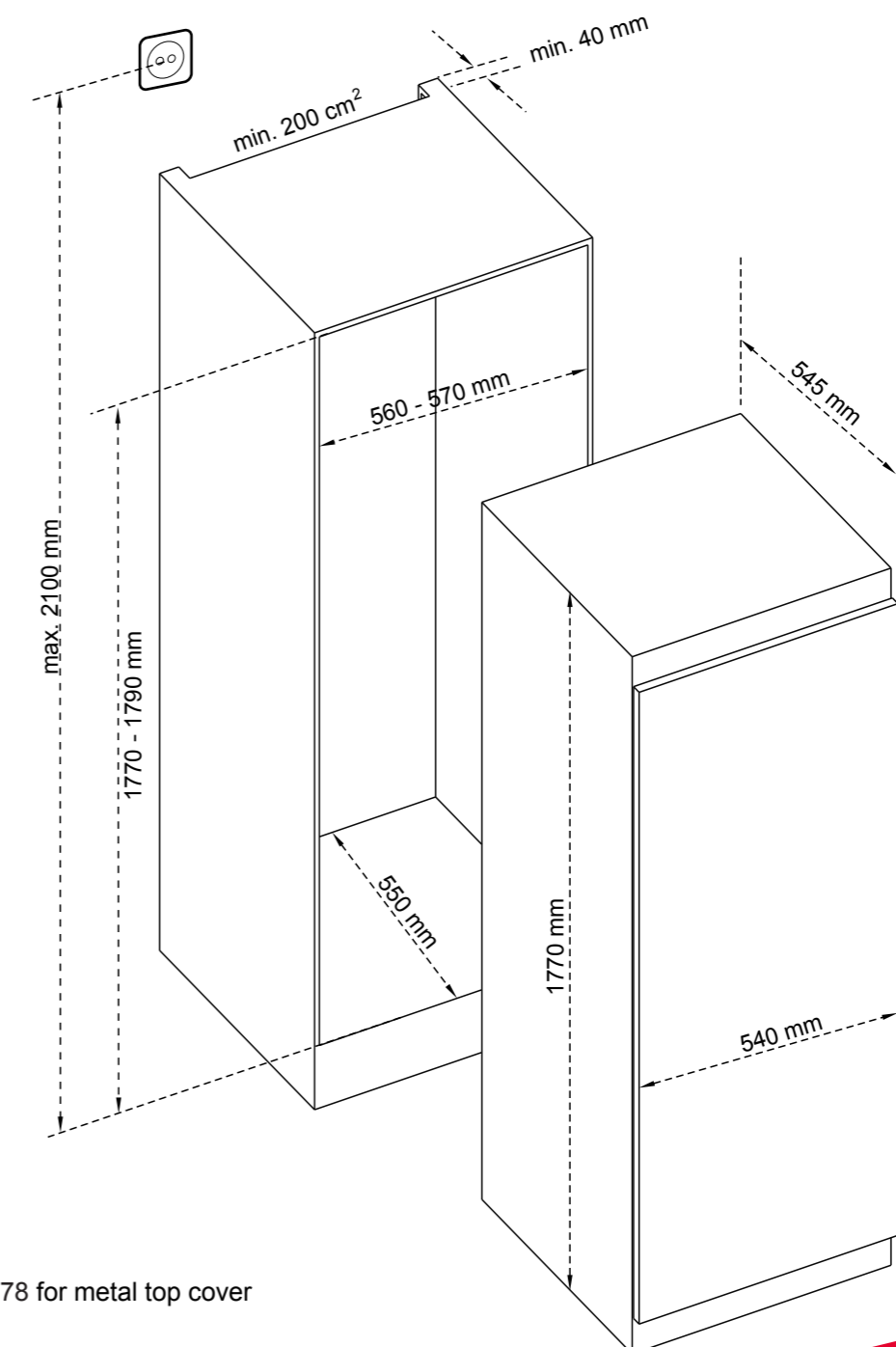

* 1770 - 1778 for metal top cover

Installation / Fridge



SJ-T1214M0X
SJ-T2214M0X / SJ-T2214M1X

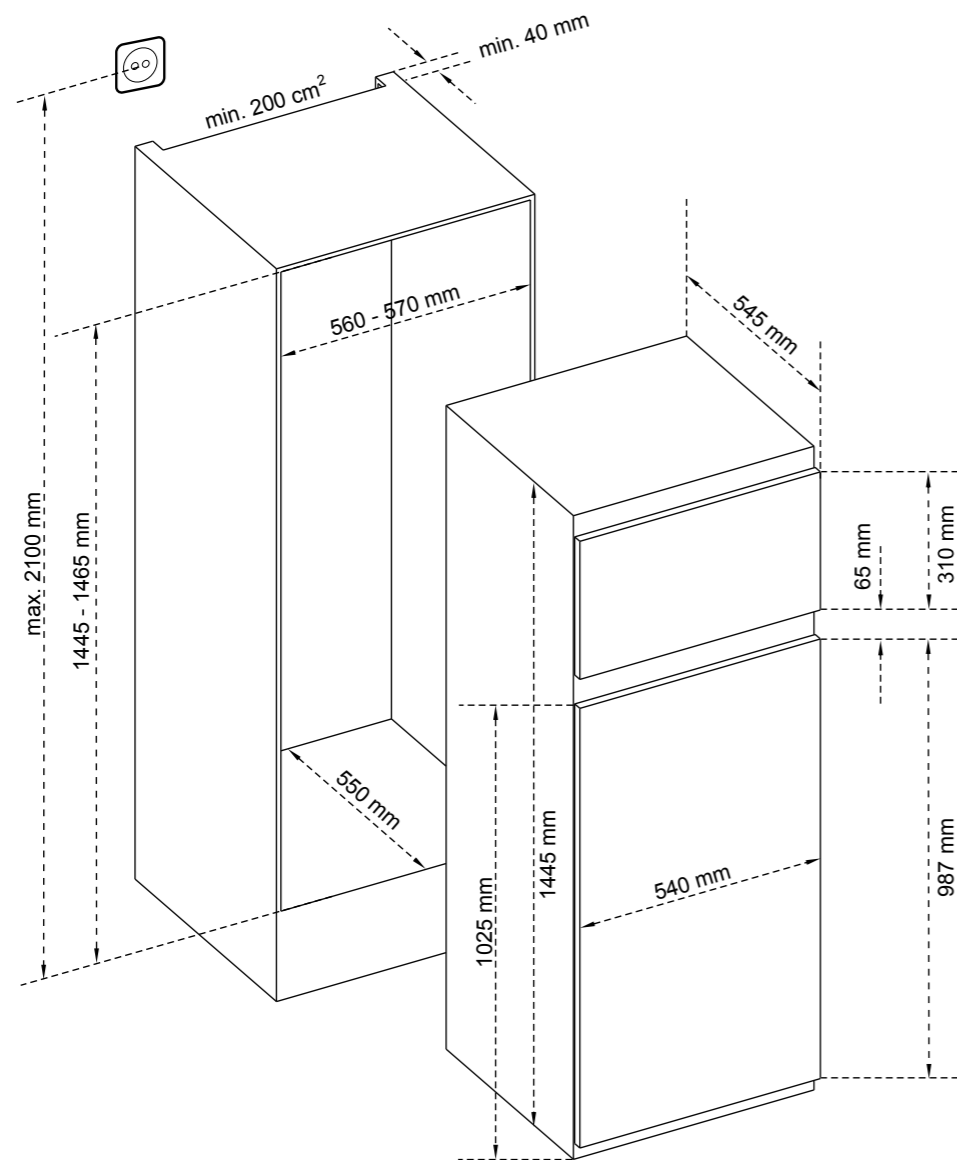

* 1445-1453 for metal top cover

Installation / Fridge



SJ-B1227M00X

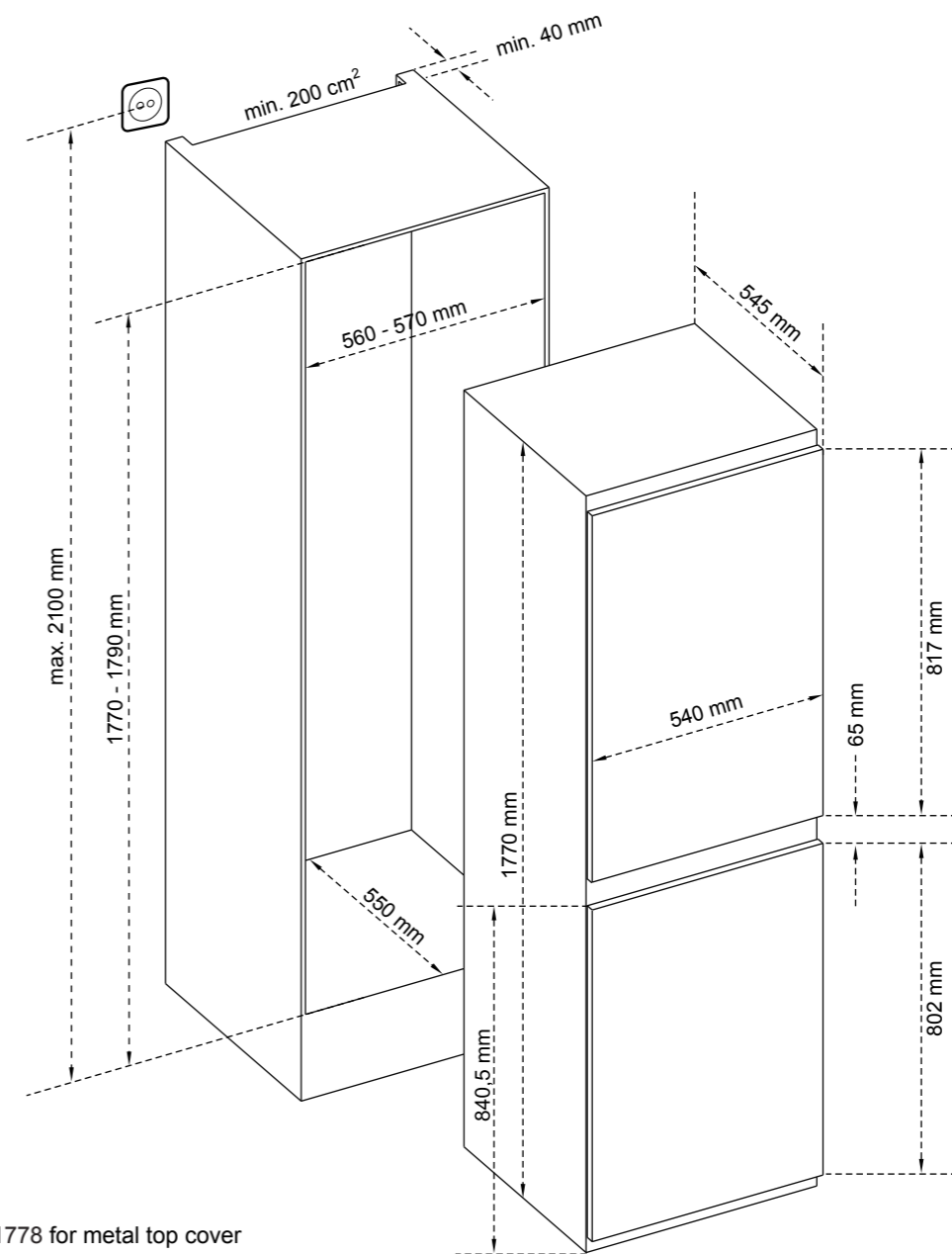

* 1770 - 1778 for metal top cover

Installation / Fridge



SJ-B1243M00X / SJ-B1243M01X
SJ-B1237M00X / SJ-B2237M01X

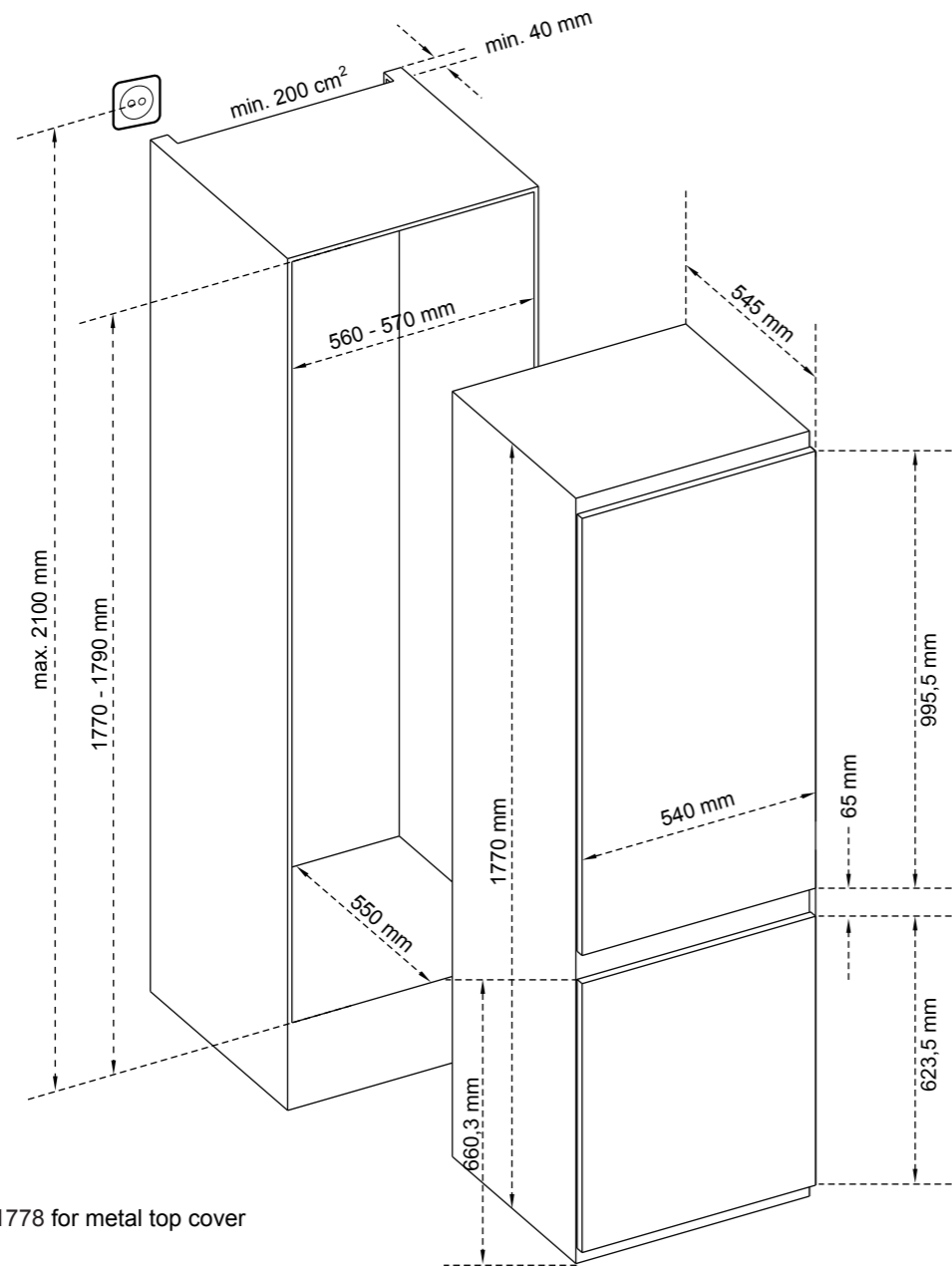

* 1770 - 1778 for metal top cover





DISCOVER PROFESSIONAL
STYLE COOKING SUPPORT
WITH OUR RANGE
OF **OVENS**

Key Features / Oven



EasyToClean Enamel

The smooth enamel interior helps make cleaning your oven easier



Catalytic Cleaning

It is easy to clean and time saving; the catalytic liners work when the oven is heated to 220°C and residue is oxidised



Pyrolytic Cleaning

Our Pyrolytic ovens mean no more scrubbing, keeping your oven sparkling clean. Self-cleaning process is set at 480°C that turns all residue to ash which can be easily removable from the oven



Key Features / Oven



ActiveCool

ActiveCool technology keeps the door temperature safe even when self-cleaning. The 4 glass panel door ensures the outer surface remains cool, even at pyrolytic temperatures (480°C)



VapClean

By softening the oven dirt with steam, the VapClean function helps take the effort out of cleaning, gently steaming the inside of your oven



Remove&Wash

Taking the hassle out of keeping your oven clean, our removable inner glass oven door makes it incredibly easy to wash even in a dishwasher



Key Features / Oven



Family Size Cavity

The bigger the better. The large cavity makes it suitable to cook for a large family



50/150 Autocooking Programs

Created by pro-chefs, 150 Built-in programs create the ultimate oven to dish experience. We have created this to make your life easier; simply press a program and let the oven do the rest: set time, temperature, and oven function



ColourLCD

4.3" Love2Cook Colour LCD Display; 5 levels of display brightness; 3 levels of buzzer tone; 11 language options



Key Features / Oven



RoastPro Meat Probe

The ultimate cooking control gets your meat just the way you like. Simply by using the sensor you can control the core temperature of your meat and make sure it is cooked to perfection

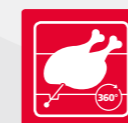

RoastPro Turnspit

RoastPro Turnspit for all round cooking perfection. It delivers perfectly cooked whole chicken every single time



PowerBoost

Getting your food off to a flying start. It reduces the preheating duration by 50%, helping you to save time and energy



Key Features / Oven



Telescopic Rails

Enables you to take heavy trays out safely and effortlessly from the hot oven



SoftClosingDoor

The oven door closes by itself gently and quietly thanks to a special hinge



DoorSwitch

It provides better vision by turning lighting on when the oven door is open and energy saving by turning off lighting when it is closed and inactive



Key Features / Oven



SteamAddedCooking

Manual or auto added moisture (thanks to a water tank with push-pull mechanism and to a steam generator)



VapClean Plus

Steam cleaning programme to soften the oven dirt. The oven generates steam with water from the tank



Antifingerprint

Enables you to take heavy trays out safely and effortlessly from the hot oven



KS-73S56BSS BI Oven



Key Features

- 78 lt, Steam Assisted Built-in Oven
- Steam Assisted cooking
- VapClean Plus
- Energy Class: A
- Black
- Colour TFT Timer (11 languages)
- Multifunctional oven + 150 Autocooking Programs
- Oven Light (top)
- 10 Functions: Ovenlight, Defrost, Turbo, Top+Bottom, Top+Bottom+Fan, Pizza, Grill+Turnspit, Double Grill+Turnspit, Double Grill+Fan+Turnspit, VapClean Plus
- Wire rack + 1 set of full telescopic rails
- Removable inner glass
- SoftClosingDoor + PowerBoost
- 1 Shallow tray, 1 Deep tray, 1 Small tray + Pizza set (optional) + Meat Probe



KS-70S50BSS / KS-70S50ISS / KS-70S50ASS BI Oven



Key Features

- 78 lt, Built-in Oven
- Catalytic Cleaning & VapClean
- Energy Class: A
- Black / Inox (Antifingerprint) / Dark Inox
- Colour TFT Timer (11 languages)
- Multifunctional oven + 150 Autocooking Programs
- Oven Light (top + sides) + DoorSwitch
- 10 Functions: Ovenlight, Defrost, Turbo, Top+Bottom, Top+Bottom+Fan, Pizza, Grill+Turnspit, Double Grill+Turnspit, Double Grill+Fan+Turnspit, VapClean
- Wire rack + 1 set of standard telescopic rails
- Removable inner glass
- SoftClosingDoor + PowerBoost
- 1 Shallow tray, 1 Deep tray, 1 Small tray + Pizza set (optional) + Meat Probe

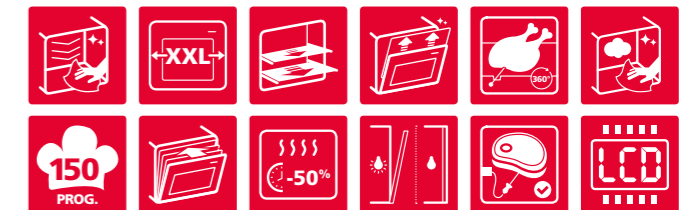

K-71V28IM2 / K-71V28AM2 / K-71V28BM2 BI Oven



Key Features

- 78 lt, Pyrolytic Built-in Oven
- ActiveCool technology
- Energy Class: A
- Inox (Antifingerprint) / Dark Inox / Black
- Touch + Timer
- Multifunctional oven (fan+ring)
- Oven Light (top)
- 8 Functions: Defrost, Top+Bottom, Top+Bottom+Fan, Grill, Double Grill, Pyrolysis, Double Grill+Fan, Turbo
- Wire rack + 1 set of full telescopic rails
- Removable inner glass + SoftClosingDoor
- 1 Shallow tray, 1 Deep tray



K-70V19BM2 / K-70V19IM2 / K-70V19AM2 BI Oven



Key Features

- 78 lt, Catalytic (back panel)
- Energy Class: A
- Black / Inox (Antifingerprint) / Dark Inox
- Touch + Timer
- Multifunctional oven (fan+ring)
- Oven Light (top)
- 9 Functions: Ovenlight, Defrost, Top+Bottom, Top+Bottom+Fan, Bottom+Fan, Grill, Double Grill, Double Grill+Fan, Fan+Ring
- Wire rack + 1 set of standard telescopic rails
- Removable inner glass
- 1 Shallow tray, 1 Deep tray, 1 Small tray



K-70V51IM2 BI Oven



Key Features

- 78 lt, Catalytic (back panel)
- Energy Class: A
- Inox (Antifingerprint)
- Touch + Timer
- Multifunctional oven (fan+ring)
- Oven Light (top)
- 10 Functions: Ovenlight, Defrost, Top+Bottom, Top+Bottom+Fan, Bottom+Fan, Grill, Double Grill, Double Grill+Fan, Fan+Grill VapClean
- Wire rack + 1 set of standard telescopic rails
- Removable inner glass
- 1 Shallow tray, 1 Deep tray, 1 Small tray

KS-70T50BHH BI Oven



Key Features

- 78 lt, Built In Oven
- Catalytic Cleaning & VapClean
- Energy Class: A
- Black Monochrome TFT Timer
- Multifunctional oven + 50 Autocooking Programs
- Oven Light (top + sides) + DoorSwitch
- 10 Functions: Ovenlight, Defrost, Turbo, Top+Bottom, Top+Bottom+Fan, Pizza, Grill+Turnspit, Double Grill+Turnspit, Double Grill+Fan+Turnspit, VapClean
- Wire rack + 1 set of full telescopic rails
- Removable inner glass
- SoftClosingDoor + PowerBoost
- 1 Shallow tray, 1 Deep tray, 1 Small tray



K-70F19BM2 BI Oven



Key Features

- 78 lt, Grey enamel
- Catalytic Panel
- Energy Class: A
- Black panel
- Full touch & slim control panel
- Multifunctional oven
- Oven Light (top)
- 9 Functions: Ovenlight, Defrost, Top+Bottom, Top+Bottom+Fan, Bottom+Fan, Grill, Double Grill, Double Grill+Fan+Ring
- Wire rack + 1 set of standard telescopic rails
- Removable inner glass
- 1 Shallow tray, 1 Deep tray



K-61D27BM1 / K-61D27IM1 BI Oven



Key Features

- 68 lt, Pyrolytic Built-in Oven
- ActiveCool technology
- Energy Class: A
- Black / Inox (Antifingerprint)
- Digital Timer
- Fan Assisted oven
- Oven Light (top)
- 6 Functions: Defrost, Top+Bottom, Top+Bottom+Fan, Grill, Double Grill, Pyrolysis
- Wire rack
- Removable inner glass
- 1 Shallow tray, 1 Deep tray

K-60V19BQM / K-60V19IQM BI Oven



Key Features

- 69 lt, Silent Built-in Oven
- Catalytic Cleaning
- Energy Class: A
- Noise level: 35 dB(A)
- Black / Inox (Antifingerprint)
- Touch + Timer
- Multifunctional oven
- Oven Light (top)
- 9 Functions: Ovenlight, Defrost, Top+Bottom, Top+Bottom+Fan, Bottom+Fan, Grill, Double Grill, Double Grill+Fan, Fan+Ring
- Wire rack
- Removable inner glass
- 1 Shallow tray, 1 Deep tray

K-61V28BM1 / K-61V28IM1 BI Oven



Key Features

- 68 lt, Pyrolytic Built-in Oven
- ActiveCool technology
- Energy Class: A
- Black / Inox (Antifingerprint)
- Touch + Timer
- Multifunctional oven (fan+ring)
- Oven Light (top)
- 8 Functions: Defrost, Top+Bottom, Top+Bottom+Fan, Grill, Double Grill, Pyrolysis, Double Grill+Fan, Turbo
- Wire rack
- Removable inner glass
- 1 Shallow tray, 1 Deep tray

K-70F19BQM BI Oven



Key Features

- 78 lt, Silent Built-in Oven
- Catalytic Cleaning
- Energy Class: A
- Black panel
- Full touch & slim control panel
- Multifunctional oven with PowerBoost
- Oven Light (top)
- 9 Functions: Ovenlight, Defrost, Top+Bottom, Top+Bottom+Fan, Bottom+Fan, Grill, Double Grill, Double Grill+Fan, Fan+Ring
- Wire rack + Standard Telescopic Rails
- Removable inner glass
- 1 Shallow tray, 1 Deep tray

K-60D22BM1 / K-60D22IM1 BI Oven



Key Features

- 69 lt, Fan Assisted Built-in Oven
- Energy Class: A
- Black / Inox (Antifingerprint)
- Easy to Clean Grey Enamel
- Touch Timer
- Fan Assisted oven
- Oven Light (top)
- 8 Functions: Ovenlight, Defrost, Top+Bottom, Top+Bottom+Fan, Bottom+Fan, Grill, Double Grill, Double Grill+Fan
- Wire rack
- Removable inner glass
- 1 Shallow tray, 1 Deep tray

K-50M15BL2 / K-50M15IL2 BI Oven



Key Features

- 64 lt, Static Built-in Oven
- Energy Class: A
- Black / Inox (Antifingerprint)
- Easy to Clean Grey Enamel
- Mechanical Timer
- Oven Light (top)
- 6 Functions: Top, Ovenlight, Top+Bottom, Bottom, Grill, Double Grill
- Molded rack
- 1 Shallow tray, 1 Deep tray



K-50M22BL2 / K-50M22IL2 BI Oven



Key Features

- 65 lt, Fan Assisted Built-in Oven
- Energy Class: A
- Black / Inox (Antifingerprint)
- Easy to Clean Grey Enamel
- Mechanical Timer
- Fan Assisted
- Oven Light (top)
- 8 Functions: Ovenlight, Defrost, Top+Bottom, Top+Bottom+Fan, Bottom+Fan, Grill, Double Grill, Double Grill+Fan
- Molded rack
- 1 Shallow tray, 1 Deep tray

Accessories / Oven

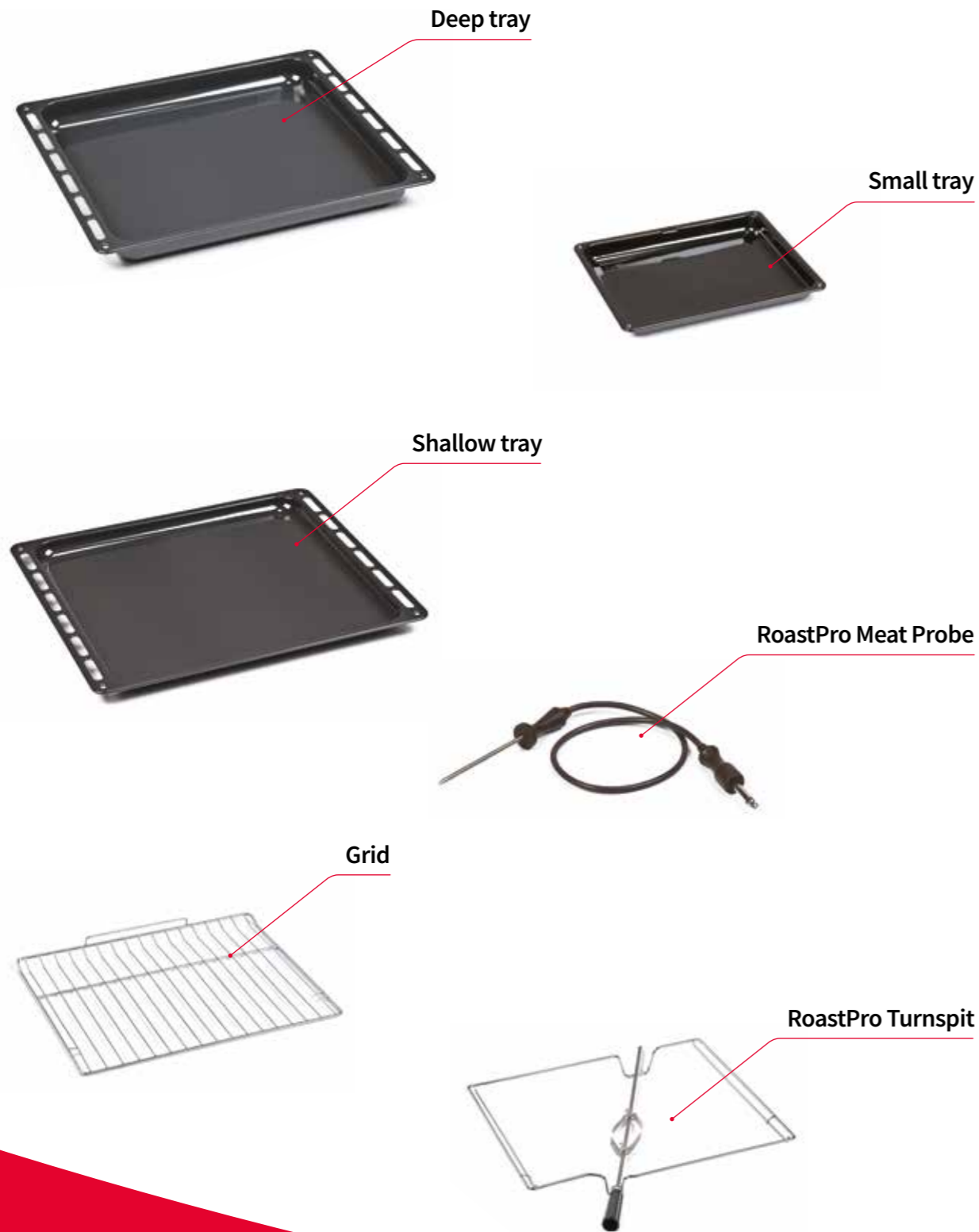

Installation / Oven



60 cm BI Oven

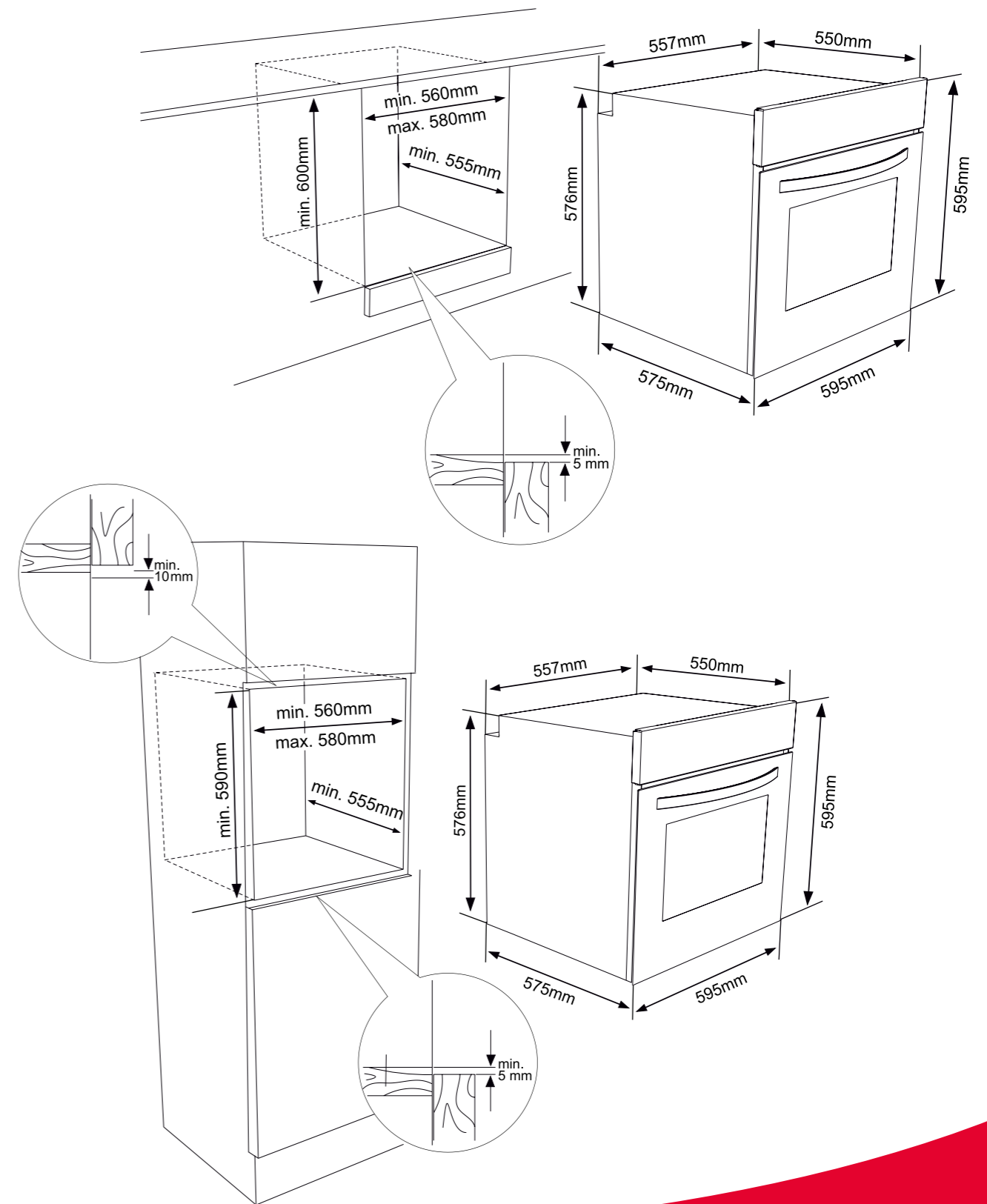

COOKS CAN ENJOY
MORE POWER AT THEIR
FINGERTIPS WITH OUR
RANGE OF ULTRA-FAST
AND EFFICIENT **HOB**S



Key Features / Hob



CookBridge

The ultimate in versatility CookBridge provides flexibility for pans of all shapes and sizes. By simply combining two induction zones you can create an extra large zone for big pots and pans



SliderTouch

Intuitive sliding controls allow you to select the power level easily

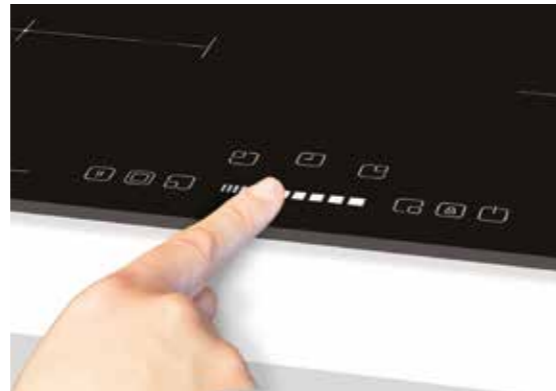

Induction Boost

Maximum power in seconds for a speed-up heating and a cooking time reduction



Key Features / Hob



AutoHeatControl

Simple yet effective, Sharp puts the most common cooking tasks at your fingertips, allowing you to boil, fry, melt chocolate and keep your food warm at the touch of a button

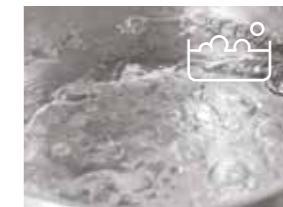

Stop&Go

Freeze time when you need to. Our Stop&Go technology allows you to pause and take that all important call when cooking, then press again to continue

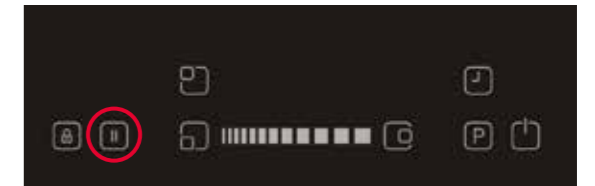

Timer Function

When the hob is switched on, an independent timer (1 to 99 minutes) can be programmed for every cooking zone so that they switch off automatically. When the hob is switched off, you also have the possibility to set a minute minder



Key Features / Hob



Extended2xZone

This extendable cooking zone allows you flexibility to cook with pans of different size perfectly



3xZone

Small to large size variation, our 3xZone allows true flexibility when it comes to selecting the perfect size for your pans



2xZone

Small to medium size variation, our 2xZone allows true flexibility when it comes to selecting the perfect size for your pans



EasyToClean Surface

The smooth glass ceramic surface is especially easy to clean



KH-9I26CT00 BI Induction Hob



Key Features

- 90 cm, 5 zones
- Black colour
- No frame, 4-side bevel
- 2x16cm 1400W / Boost 1800W
- 2x20cm 2100W / Boost 2500W
- 1x25cm 2800W / Boost 3500W
- Total power: 10800W
- Front Touch Control, 5 Timers
- Hot Surface Indicator
- Key Lock
- Stop&Go

SCHOTT
CERAN®

KH-7I19CS00 BI Induction Hob



Key Features

- 78 cm, 4 zones
- Black colour
- No frame, 4 side bevel
- 2x16cm 1400W / Boost 1800W
- 2x20cm 2100W / Boost 2500W
- Total power: 10800W
- SliderTouch Control, 4 Timers
- Hot Surface Indicator
- Key Lock
- Stop&Go
- AutoHeatControl

SCHOTT
CERAN®

KH-6I27CS00 BI Induction Hob

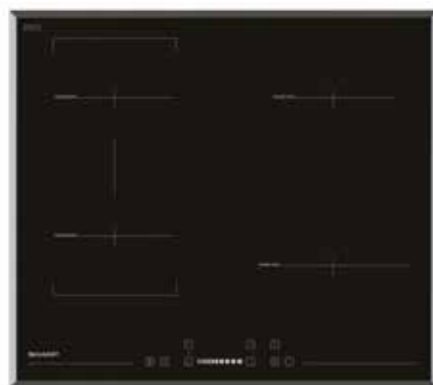

Key Features

- 60 cm, 4 zones
- Black colour
- No frame, 4-side bevel
- 3x16cm 1400W / Boost 1800W
- 1x21cm 2100W / Boost 2500W
- CookBridge (35,4x16cm): 2800W / Boost 3600W
- Total power: 7400W
- SliderTouch Control, 4 Timers
- Hot Surface Indicator
- Key Lock
- Stop&Go
- AutoHeatControl

SCHOTT
CERAN®

KH-7I18CT00 BI Induction Hob

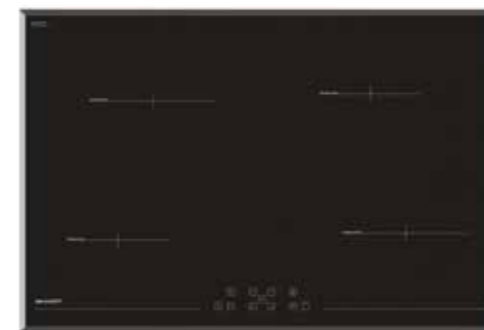

Key Features

- 78 cm, 4 zones
- Black colour
- No frame, 4 side bevel
- 2x16cm 1400W / Boost 1800W
- 2x20cm 2100W / Boost 2500W
- Total power: 7400W
- Touch Control, 4 Timers
- Hot Surface Indicator
- Key Lock
- Stop&Go
- AutoHeatControl

SCHOTT
CERAN®

KH-6I34BS00 BI Induction Hob



Key Features

- 60 cm, 3 zones
- Black colour
- No frame, front bevel
- 2x16cm 1400W / Boost 1800W
1x29cm 2800W / Boost 3500W
- CookBridge (35,4x16cm) 2800W / Boost 3600W
- Total power: 7200W
- SliderTouch Control, 3 Timers
- Hot Surface Indicator
- Key Lock
- Stop&Go
- AutoHeatControl

SCHOTT
CERAN®

KH-6I19BS00 BI Induction Hob

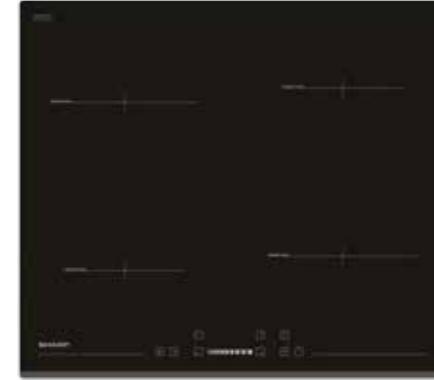

Key Features

- 60 cm, 4 zones
- Black colour
- No frame, front bevel
- 2x16cm 1400W / Boost 1800W
2x21cm 2100W / Boost 2500W
- Total power: 7400W
- SliderTouch Control, 4 Timers
- Hot Surface Indicator
- Key Lock
- Stop&Go
- AutoHeatControl

SCHOTT
CERAN®

KH-6I31BS00 BI Induction Hob



Key Features

- 60 cm, 3 zones
- Black colour
- No frame, front bevel
- 1x16cm 1400W / Boost 1800W
1x21cm 2100W / Boost 2500W
1x29cm 2800W / Boost 3500W
- Total power: 7200W
- SliderTouch Control, 3 Timers
- Hot Surface Indicator
- Key Lock
- Stop&Go
- AutoHeatControl

SCHOTT
CERAN®

KH-6I19FT00 BI Induction Hob

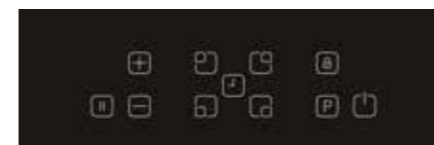
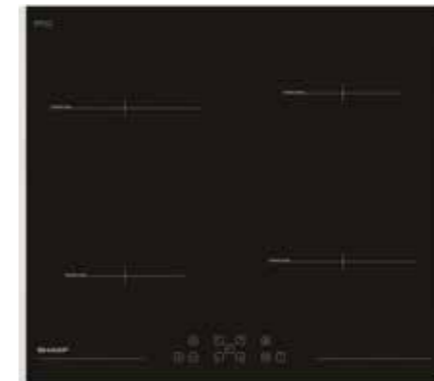

Key Features

- 60 cm, 4 zones
- Black colour
- 2-side inox frame, no bevel
- 2x16cm 1400W / Boost 1800W
2x21cm 2100W / Boost 2500W
- Total power: 7400W
- Front Touch Control, 4 Timers
- Hot Surface Indicator
- Key Lock
- Stop&Go
- AutoHeatControl

SCHOTT
CERAN®

Installation / Induction Hob



New generation 60 cm Induction Hob

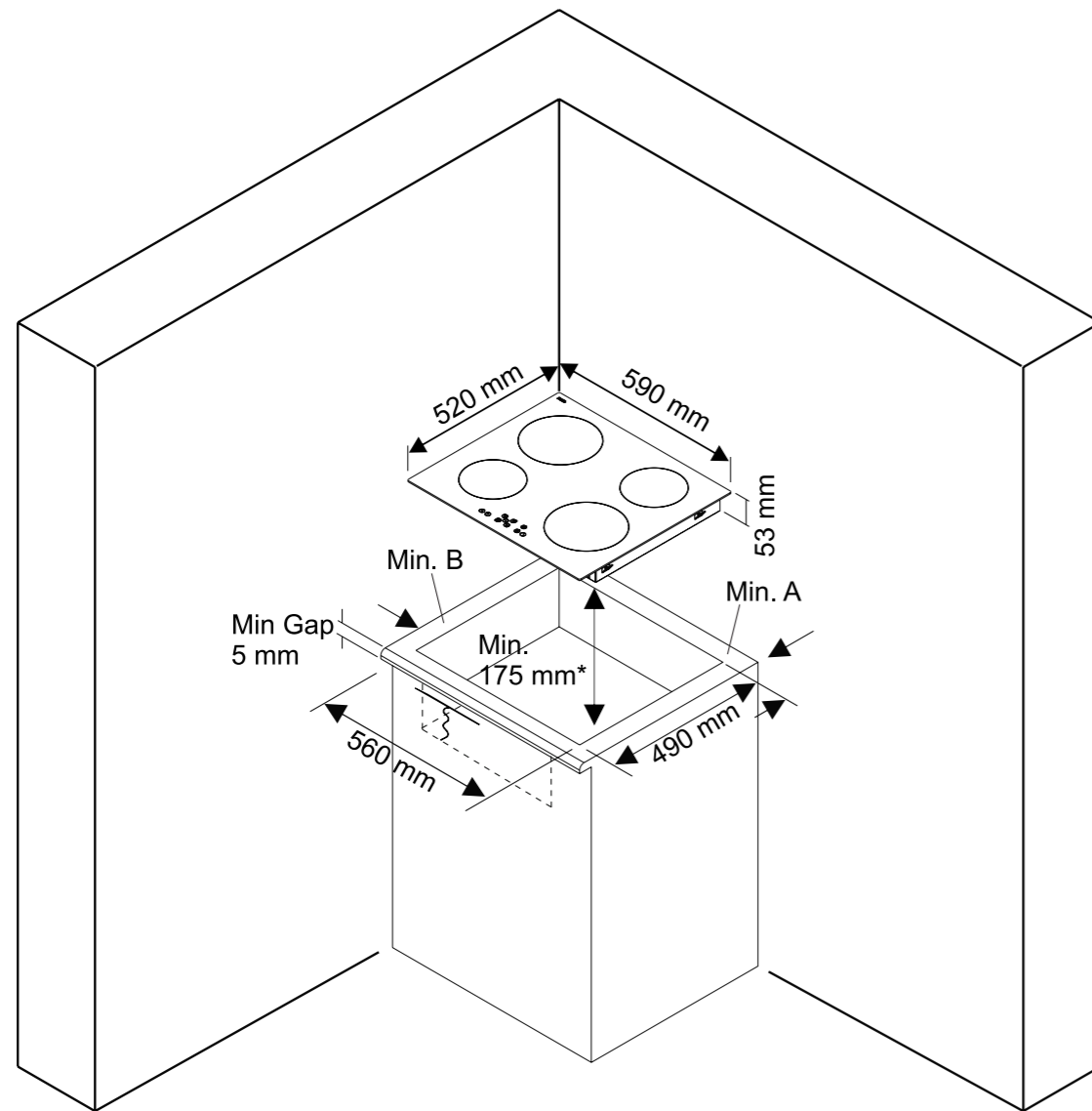

Neighbourhood walls	A mm	B mm
Wood	40	40
Concrete or ceramic tiled	25	25

*In the case of installation over Built-in oven, distance should be min. 10 mm.

Installation / Induction Hob



New generation 78 cm Induction Hob

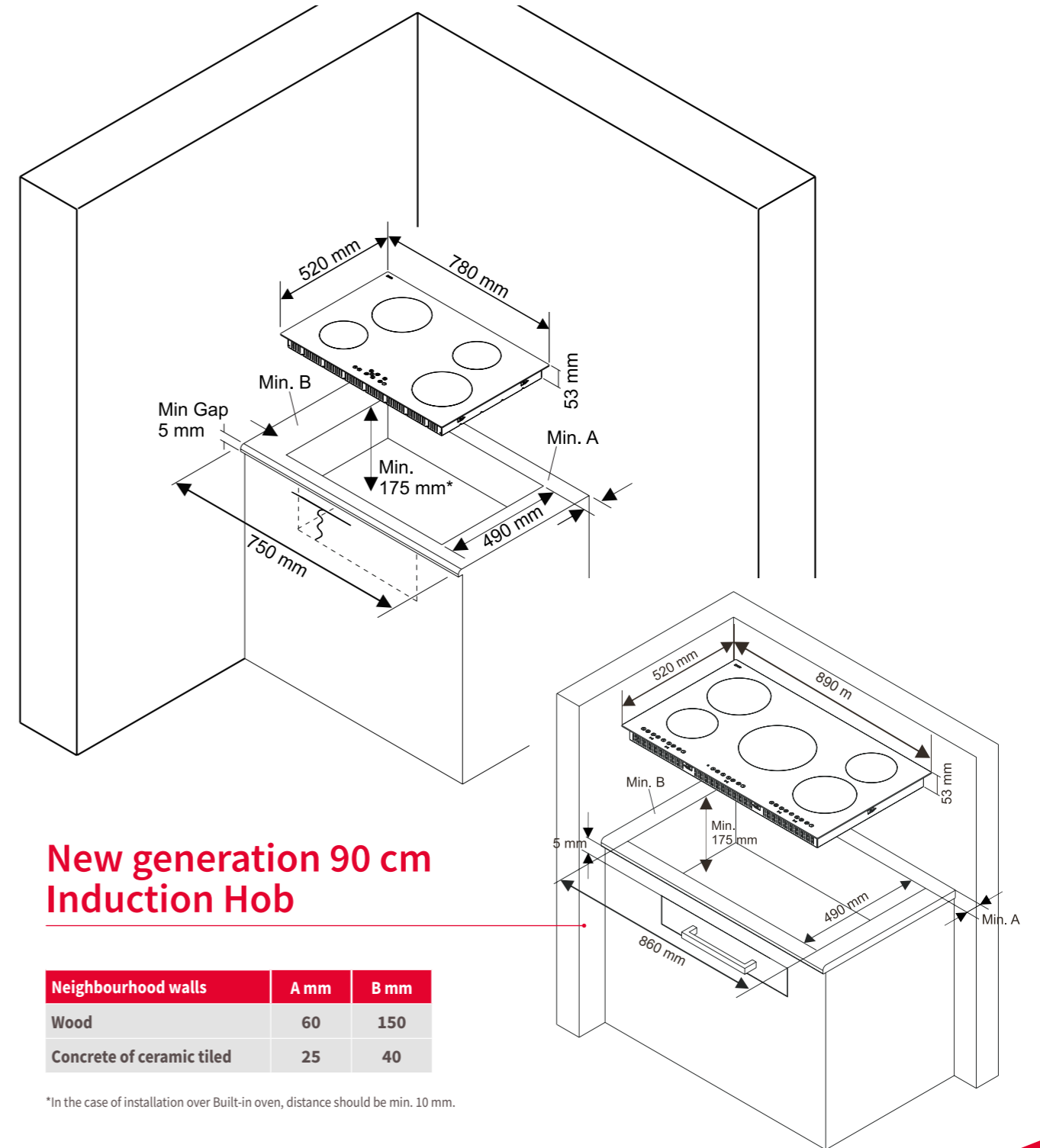

New generation 90 cm Induction Hob

Neighbourhood walls	A mm	B mm
Wood	60	150
Concrete or ceramic tiled	25	40

*In the case of installation over Built-in oven, distance should be min. 10 mm.

KH-6V09CS00 BI Vitroceramic Hob



Key Features

- 60 cm, 4 zones
- Black colour
- No frame, 4-side bevel
- 2x14,5cm 1200W
- 1x18cm "2xZone" 1700W
- 1x14,5-25,2cm "Extended 2xZone" 1800W
- Total power: 5900W
- Slider Touch Control, 4 Timers
- Hot Surface Indicator

SCHOTT
CERAN®

KH-6V13BS00 BI Vitroceramic Hob

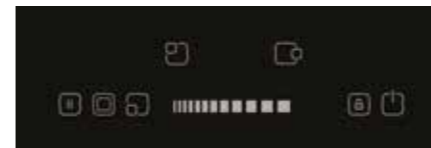

Key Features

- 60 cm, 3 zones
- Black colour
- No frame, front bevel
- 1x14,5cm 1200W
- 1x18cm 1800W
- 1x27cm "3xZone" 2700W
- Total power: 5700 W
- Slider Touch Control, 3 Timers
- Hot Surface Indicator

SCHOTT
CERAN®

KH-6V08BS00 BI Vitroceramic Hob

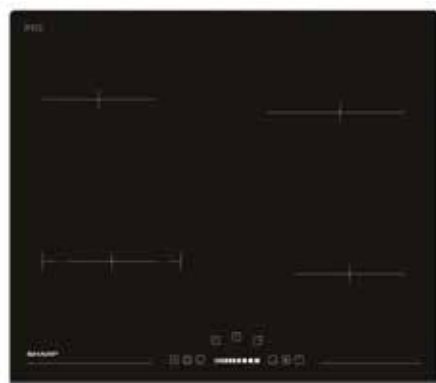

Key Features

- 60 cm, 4 zones
- Black colour
- No frame, front bevel
- 2x14,5cm 1200W
- 1x18cm 1800W
- 1x18cm "2xZone" 1700W
- Total power: 5900W
- Front Touch Control, 4 Timers
- Hot Surface Indicator

SCHOTT
CERAN®

KH-6V08FT00 BI Vitroceramic Hob



Key Features

- 60 cm, 4 zones
- Black colour
- 2-side inox frame, no bevel
- 2x14,5cm 1200W
- 1x18cm 1800W
- 1x18cm "2xZone" 1700W
- Total power: 5900W
- Front Touch Control, 4 Timers
- Hot Surface Indicator

SCHOTT
CERAN®

Installation / Induction Vitroceramic Hob



60 cm Induction Vitroceramic Hob with Front Triangular Touch Control

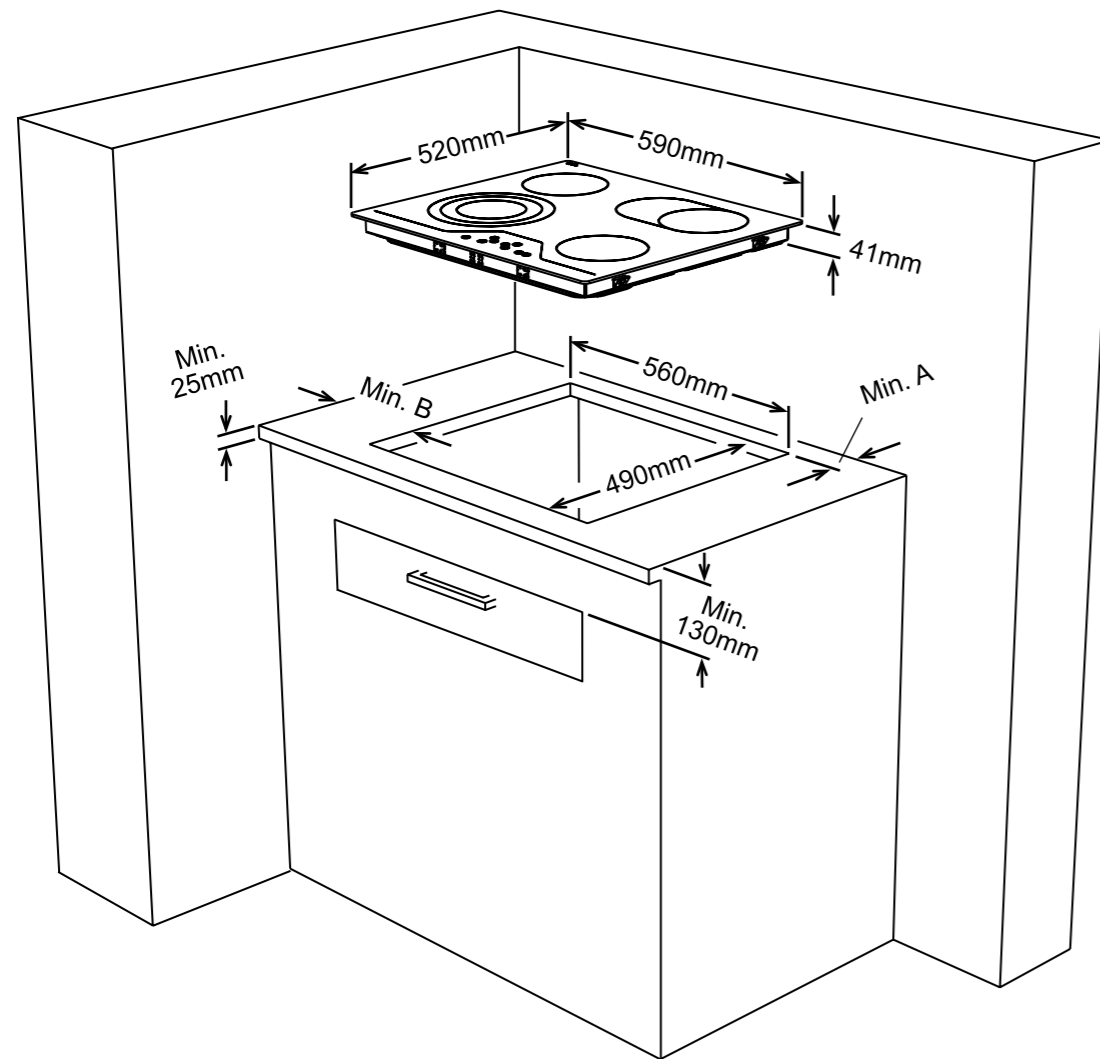

Neighbourhood walls	A mm	B mm
Combustible	60	150
Non-combustible	25	40



K-72D19IM2 & KH-6I19FT00 BI Polyvalent Set



Key Features

- 78 lt, Built-in Oven
- Catalytic cleaning
- Energy Class: A
- Inox (Antifingerprint)
- Touch Timer
- Multifunctional oven (fan+ring)
- Oven Light (top)
- 9 Functions: Ovenlight, Defrost, Top+Bottom, Top+Bottom+Fan, Bottom+Fan, Grill, Double Grill, Double Grill+Fan, Fan+Ring
- Wire rack + 1 set of standard telescopic rails
- Removable inner glass
- 1 Shallow tray, 1 Deep tray, 1 Small tray

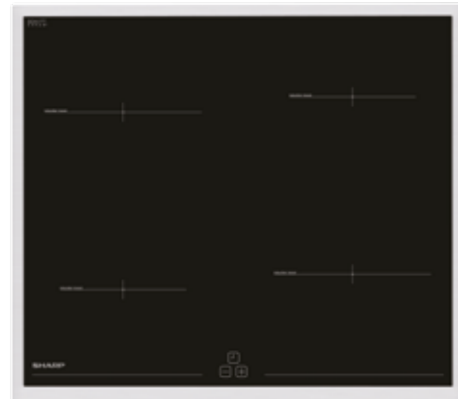

Key Features

- 60 cm, 4 zones
- Black colour
- Full inox frame, no bevel
- 2x16cm 1400W /Boost 1800W
- 2x20cm 2100W /Boost 2500W
- Total power: 7400 W
- Hob Control on oven
- Hot Surface Indicator, 4 Timers
- Key Lock
- Stop&Go

SCHOTT
CERAN®

K-62V19IM1 & KH-6V05FT00 BI Polyvalent Set



Key Features

- 69 lt, Built-in Oven
- Energy Class: A
- Inox (Antifingerprint)
- EasytoClean enamel
- Touch + Timer
- Multifunctional oven (fan+ring)
- Oven Light (top)
- 9 Functions: Ovenlight, Defrost, Top+Bottom, Top+Bottom+Fan, Bottom+Fan, Grill, Double Grill, Double Grill+Fan, Fan+Ring
- Wire rack
- Removable inner glass
- 1 Shallow tray, 1 Deep tray

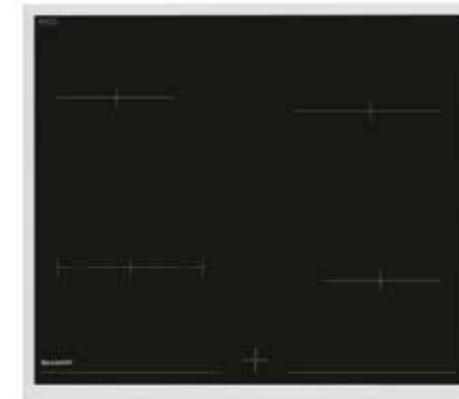

Key Features

- 60 cm, 4 zones
- Black colour
- Full inox frame, no bevel
- 2x14,5cm 1200 W
- 1x18cm 1800W
- 1x18cm "2xZone" 1700W
- Total power: 5900 W
- Hob Control on oven, 4 Timers
- Hot Surface Indicator

SCHOTT
CERAN®

K-52M15IL2 + KH-6V05FT00 BI Polyvalent Set



Key Features

- 64 lt, Built-in Oven
- Energy Class: A
- Black / Inox (Antifingerprint)
- Easy to Clean Grey Enamel
- Static oven
- Oven Light (top)
- 6 Functions: Top, Ovenlight, Top+Bottom, Bottom, Grill, Double Grill
- Molded rack
- 1 Shallow tray, 1 Deep tray

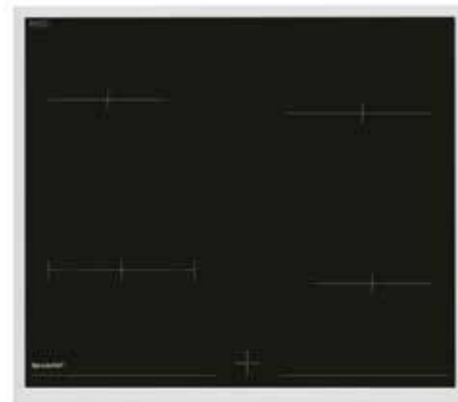

Key Features

- 60 cm, 4 zones
- Black colour
- Full inox frame, no bevel
- 2x14,5cm 1200 W
- 1x18cm 1800W
- 1x18cm "2xZone" 1700W
- Total power: 5900 W
- Hob Control on oven, 4 Timers
- Hot Surface Indicator

SCHOTT
CERAN®

Installation / BI Polyvalent Set

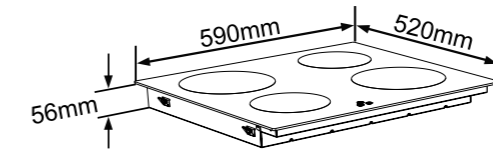

Induction Hob and BI Oven

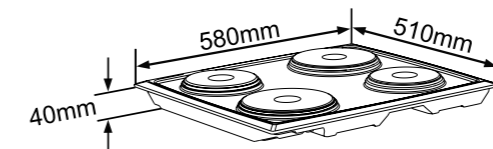

Electric Hob and BI Oven

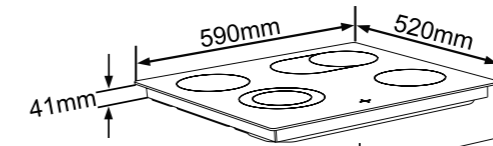

Vitroceramic Hob and BI Oven

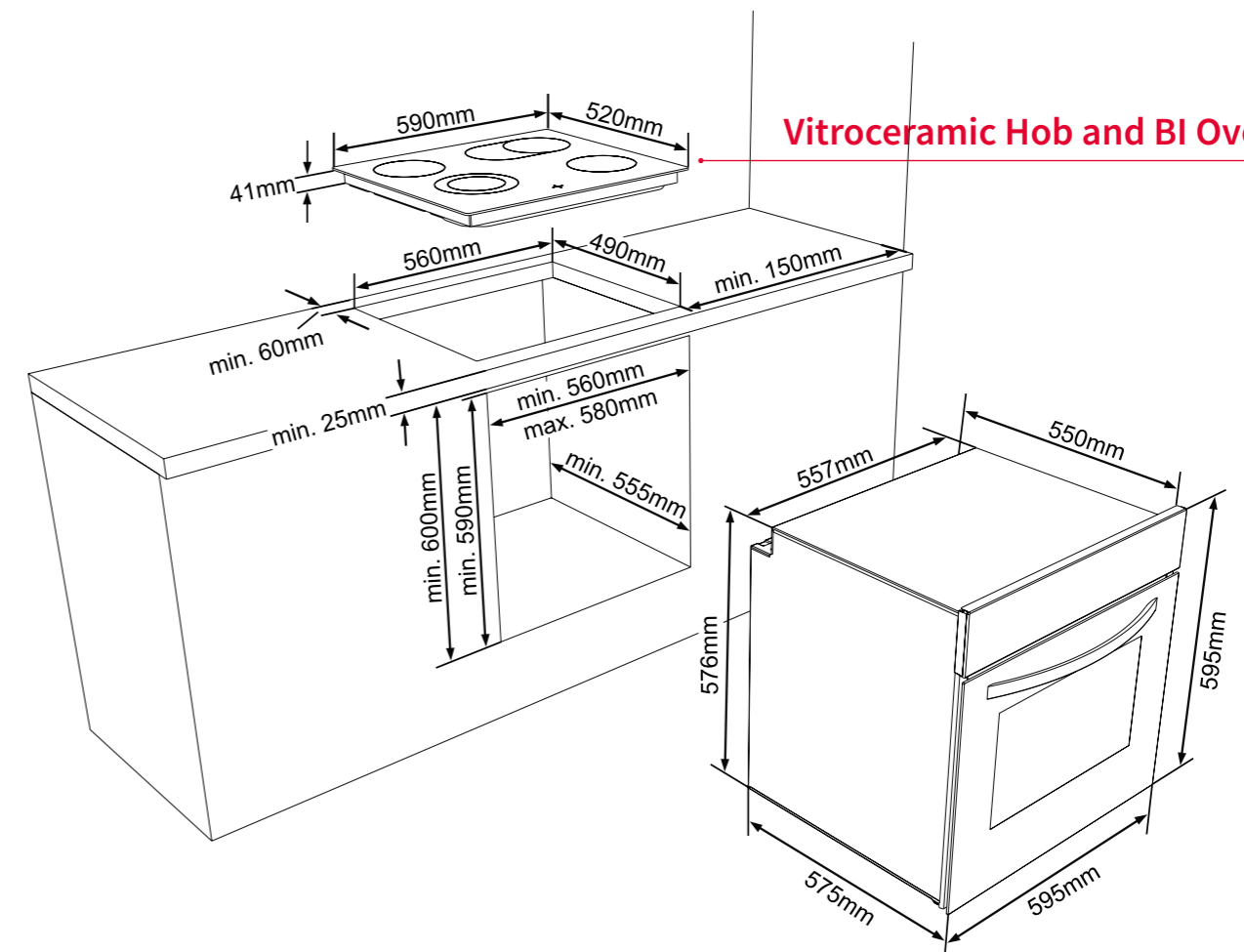



OUR **WALL-MOUNTED
COOKER** HOODS KEEP
THE AIR COOL, CLEAN
AND STEAM-FREE
IN EVERY KITCHEN

Key Features / Hood



Boost Mode

For a short period of time, this intensive mode boosts extraction (by switching the hood to maximum speed) to cope with operations like searing or boiling that generate large



Delay15

Banishing those lingering smells, the handy delay timer powers off after 15 minutes leaving the kitchen fresh



MotionSensor

The sensor turns the hood LED light on automatically when it detects any movement at any time of the day or the night, as long as this feature is activated



NightSensor

The sensor turns the hood LED light on automatically when it detects any movement during the night (7pm - 7am)



SteamSensor

The sensor turns the hood on and off automatically, depending on the steam detection

Key Features / Hood



FilterCleaning

The filter light indicates that the grease filter has to be cleaned



WashableFilter

It allows you to wash the removable grease filter, even letting you wash it in the dishwasher

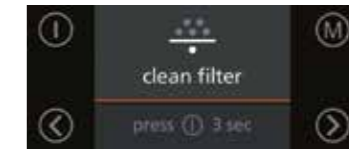

LED Light

The energy efficient LED lights provide a natural and bright lighting that illuminates the hob perfectly. It means you can always see what you are cooking

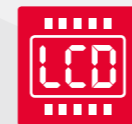

ColourLCD

2.3" colourful animated TFT LCD display. 11 language options

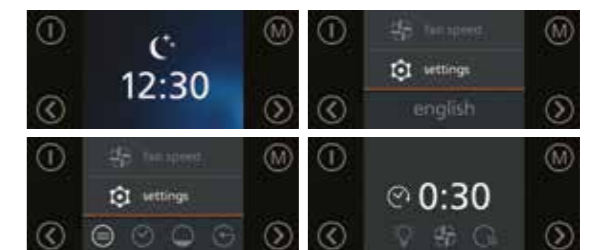

Non Return Valve

This part ensures the filtered air to return back in to the cooker hood. The valve only opens one direction. It allows air to flow from the kitchen to the outside and prevents cold air from flowing inward



KL-612TBSS BI Hood



Key Features

- Wall mounted, 60 cm
- Operating mode: extraction or recirculation
- Inox front cover & Black colored decorative glass
- Airflow (EN 61591): 570/680 (boost) m³/h
- 4+1 Speed
- Touch control on glass - 2.3" colourful TFT display
- 4W LED light (incl. back light)
- Timer & automatic turn off in 15 min (Delay15)
- Filter cleaning signal, NightSensor, SteamSensor
- Dishwasher safe, multi deck aluminum cassette filter
- Non return valve
- Energy Class: A
- Noise level (EN 60704): 62,4 dB(A) re1pW

KL-910TBMH BI Hood



Key Features

- 90 cm Wall Mounted Hood
- Operating mode: extraction or recirculation
- Inox front cover & Black colored decorative glass
- Airflow (EN 61591): 495/693 (boost) m³/h
- 4+1 Speed
- Touch control on glass
- LED light
- Timer & automatic turn off in 15 min (Delay15)
- Filter cleaning signal
- Dishwasher safe, multi deck aluminum cassette filter
- Non return valve
- Energy Class: B
- Noise level (EN 60704): 63,5 dB(A) re1pW

KL-611TBMH BI Hood



Key Features

- Wall mounted, 60 cm
- Operating mode: extraction or recirculation
- Inox front cover & Black colored decorative glass
- Airflow (EN 61591): 548/724 (boost) m³/h
- 4+1 Speed
- Touch control on glass
- 4W LED light (incl. back light)
- Timer & automatic turn off in 15 min (Delay15)
- Filter cleaning signal, MotionSensor
- Dishwasher safe, multi deck aluminum cassette filter
- Non return valve
- Energy Class: A
- Noise level (EN 60704): 65,6 dB(A) re1pW

KL-610TBLM BI Hood



Key Features

- Wall mounted, 60 cm
- Operating mode: extraction or recirculation
- Inox front cover & Black colored decorative glass
- Airflow (EN 61591): 495/693 (boost) m³/h
- 4+1 Speed
- Touch control on glass
- LED light
- Timer & automatic turn off in 15 min (Delay15)
- Filter cleaning signal
- Dishwasher safe, multi deck aluminum cassette filter
- Non return valve
- Energy Class: B
- Noise level (EN 60704): 63,5 dB(A) re1pW

Installation / BI Hood



KL-612TBSS

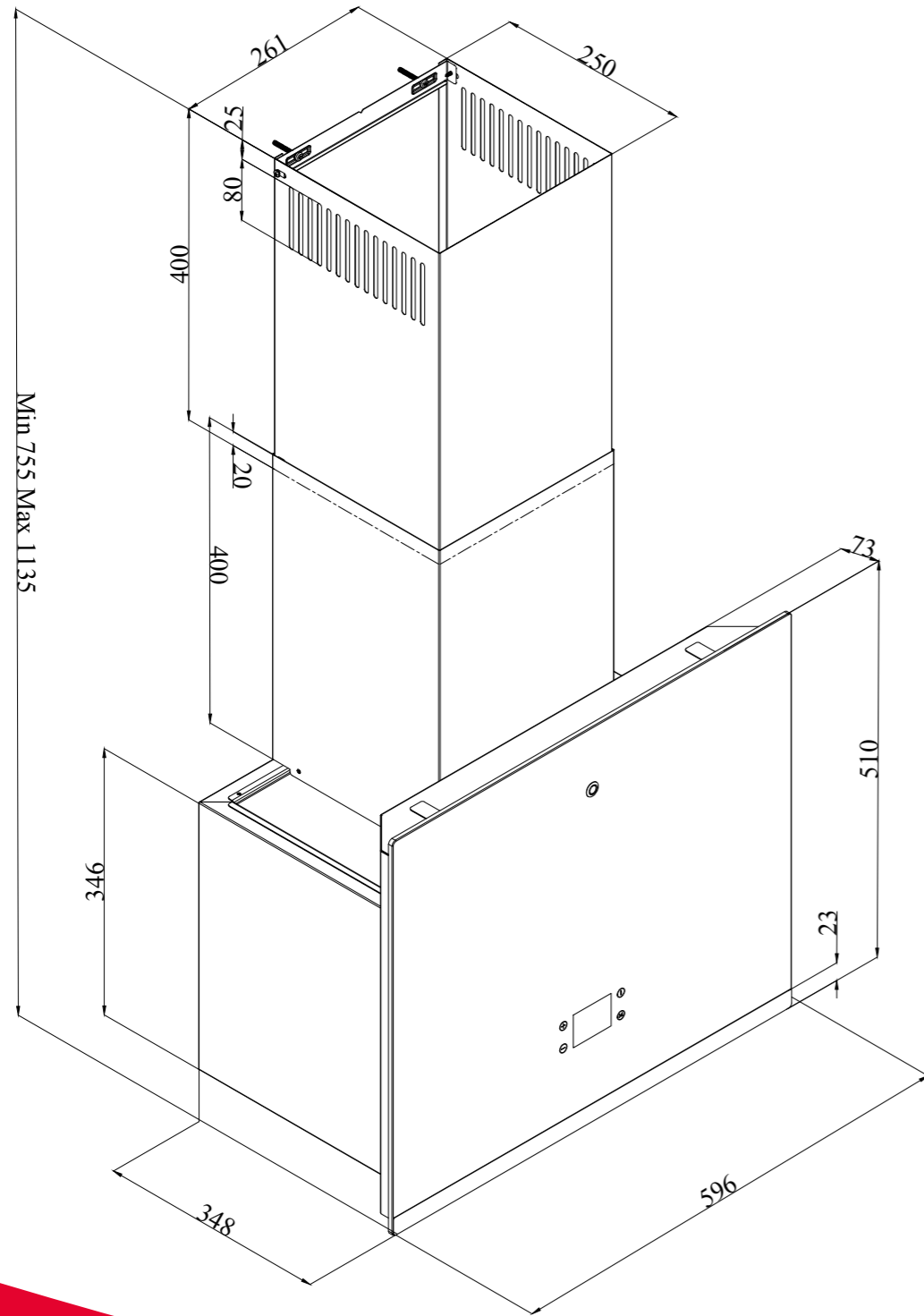

Installation / BI Hood



KL-611TBMH

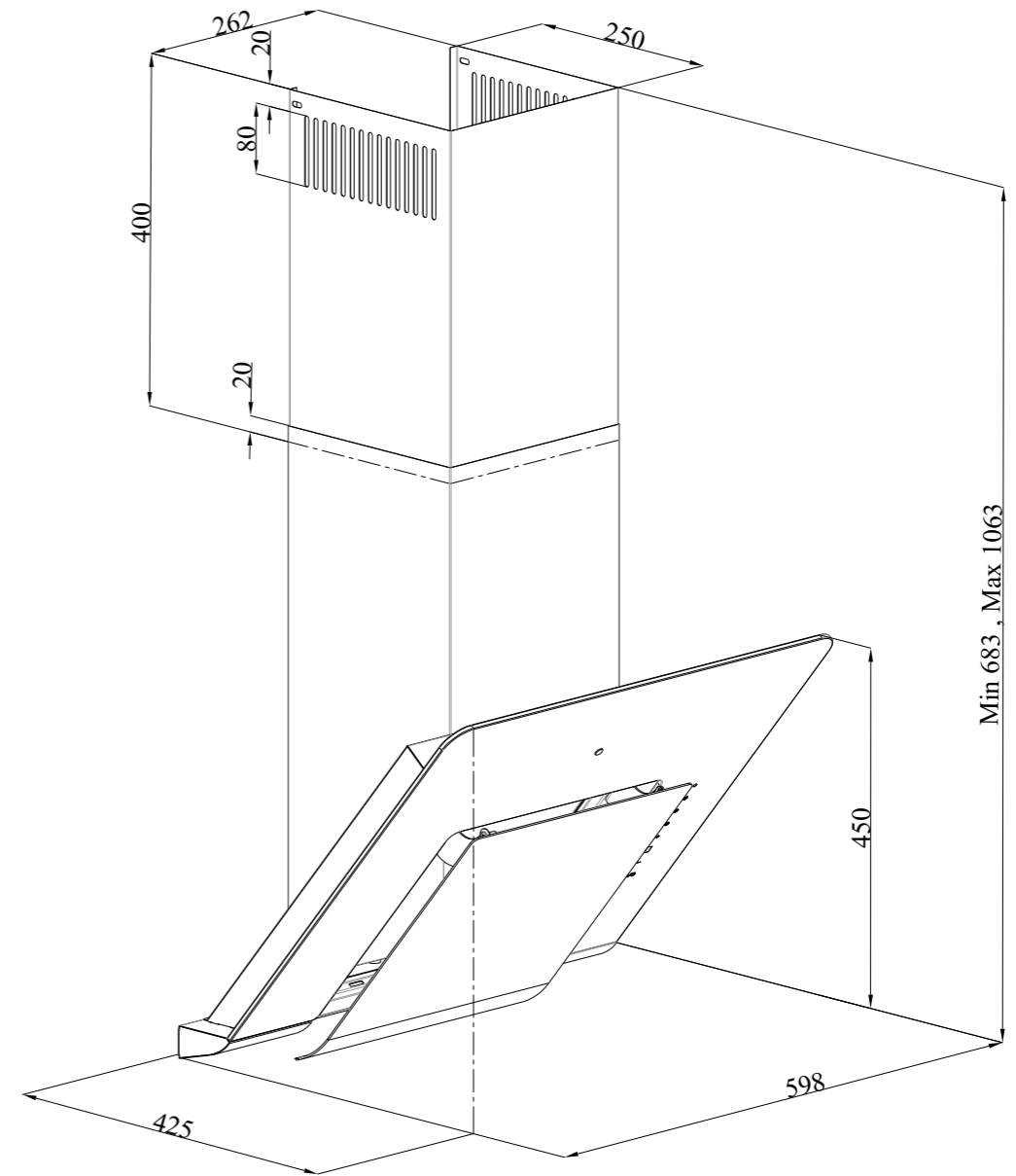

Installation / BI Hood



KL-910TBMH / KL-610TBLM

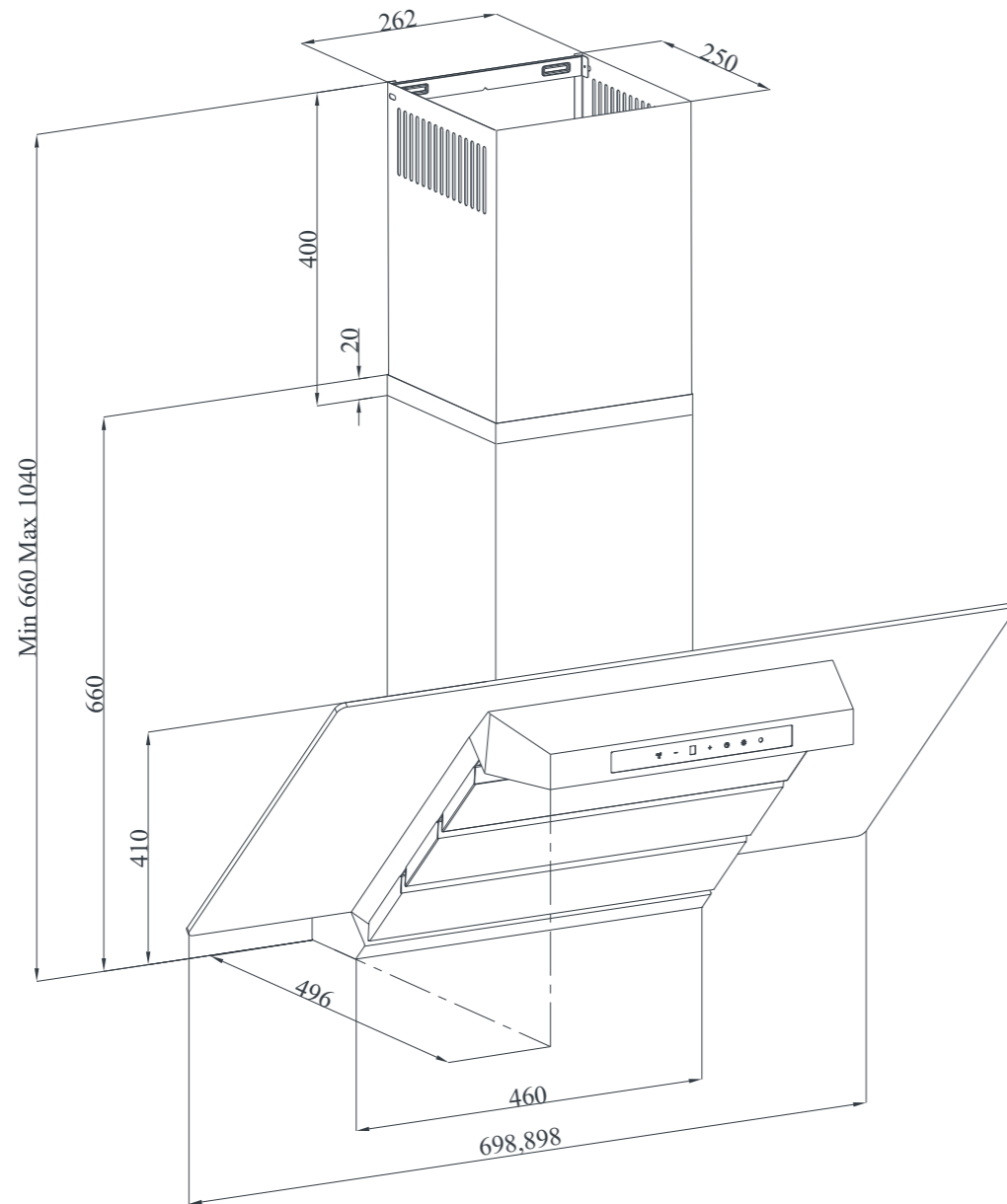

DISCOVER
THE FASTEST
DISHWASHING
CYCLES TO DATE
WITH OUR RANGE
OF **BUILT-IN
DISHWASHERS**



Key Features / Dishwasher



AquaGlide

AquaGlide provides deep precision multidirectional targeted cleaning with pin-point accuracy. The spray can be directed upward for effective wash of glasses and baby bottles or downward to achieve extra strength wash in the dishes below



WaterBlade

WaterBlade technology delivers a truly immersive powerful clean with two additional spray arms that can work both together with the main spray arm or individually



AutoDoor

This technology opens the door at the end of the wash cycle to assist the drying process, saving energy



QuickWash

Providing super-fast washing, this program can clean 4 place settings in just 14 minutes



Key Features / Dishwasher



Express 50'

Delivering top washing quality in just 50', this program is the ultimate in efficient dishwashing



Hygiene

A special filter and a range of hygiene programs help Sharp dishwashers fight harmful bacteria



Advanced Inverter Motor

Our Advanced Inverter Motor delivers superior efficiency and quieter operation, all backed by a 10yr parts warranty



DualProWash

Helps tackle the dirtiest of pans in the bottom, while taking care of your delicate glasses in the top



Key Features / Dishwasher



EcoWash

Provides the independent usage of upper and lower baskets within load options, saves energy and decrease water consumption



IntelliWash

Intelligent sensor technology measures the soil level to auto-optimize cleaning performance

TURBIDITY

WATER TEMPERATURE

PROGRAM TIME

WASH PERFORMANCE



I-LED

Don't get left in the dark, I-LED keeps you updated letting you know when the wash ends



Accessories / Dishwasher



StemSafe



Anti-Bacterial Filter



Upper Basket Height Adjustment Mechanism



Universal Cutlery Basket



Sliding Cutlery Basket



Fixed Cutlery Basket



Dishwasher
Built-in Slimline 45 cm

QW-GS53I443X BI Dishwasher Slimline 45 cm



Key Features

- Capacity: 10 PS
- N. 8 Programmes
- Slim Cabinet Type (45 cm)
- Energy Class: A+++
- Water Consumption: 9 lt.
- Antibacterial Filter
- Sound Level: 44 dB(A)
- Turbo Drying System
- N. 3 Racks
- Overflow & Leakage Protection
- Delay Timer
- ExtraSilent & ExtraDry



QW-GS52I452X BI Dishwasher Slimline 45 cm



Key Features

- Capacity: 10 PS
- N. 8 Programmes
- Slim Cabinet Type (45 cm)
- Energy Class: A++
- Water Consumption: 9 lt.
- Antibacterial Filter
- Sound Level: 45 dB(A)
- Turbo Drying System
- N. 3 Racks
- Overflow & Leakage Protection
- Delay Timer



QW-S41I472X BI Dishwasher Slimline 45 cm



Key Features

- Capacity: 10 PS
- N. 8 Programmes
- Slim Cabinet Type (45 cm)
- Energy Class: A++
- Water Consumption: 9 lt.
- Antibacterial Filter
- Sound Level: 47 dB(A)
- Turbo Drying System
- N. 3 Racks
- Overflow & Leakage Protection
- Delay Timer



QW-S12I492X BI Dishwasher Slimline 45 cm



Key Features

- Capacity: 10 PS
- N. 3 Programmes
- Slim Cabinet Type (45 cm)
- Energy Class: A++
- Water Consumption: 11 lt.
- Antibacterial Filter
- Sound Level: 49 dB(A)
- Active Drying System
- N. 2 Racks
- Overflow & Leakage Protection



QW-S32I472X BI Dishwasher Slimline 45 cm



Key Features

- Capacity: 10 PS
- N. 8 Programmes
- Slim Cabinet Type (45 cm)
- Energy Class: A++
- Water Consumption: 11 lt.
- Antibacterial Filter
- Sound Level: 47 dB(A)
- Active Drying System
- N. 2 Racks
- Overflow & Leakage Protection
- Delay Timer

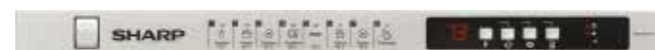



Dishwasher
Built-in Fullsize 60 cm

QW-GD54R443X BI Dishwasher Fullsize 60 cm



Key Features

- Capacity: 15 PS
- N. 8 Programmes
- Cabinet Type (60 cm)
- Energy Class: A+++
- Water Consumption: 9 lt.
- Antibacterial Filter
- Sound Level: 44 dB(A)
- Turbo Drying System
- N. 3 Racks
- Overflow & Leakage Protection
- Delay Timer
- AquaGlide & WaterBlade
- ExtraSilent & ExtraDry



QW-GD53I443X BI Dishwasher Fullsize 60 cm



Key Features

- Capacity: 15 PS
- N. 8 Programmes
- Cabinet Type (60 cm)
- Energy Class: A+++
- Water Consumption: 9 lt.
- Antibacterial Filter
- Sound Level: 44 dB(A)
- Turbo Drying System
- N. 3 Racks
- Overflow & Leakage Protection
- Delay Timer
- ExtraSilent & ExtraDry



QW-GD52I472X BI Dishwasher Fullsize 60 cm



Key Features

- Capacity: 15 PS
- N. 8 Programmes
- Cabinet Type (60 cm)
- Energy Class: A++
- Water Consumption: 9 lt.
- Antibacterial Filter
- Sound Level: 47 dB(A)
- Turbo Drying System
- N. 3 Racks
- Overflow & Leakage Protection
- Delay Timer



QW-D21I492X BI Dishwasher Fullsize 60 cm



Key Features

- Capacity: 13 PS
- N. 5 Programmes
- Cabinet Type (60 cm)
- Energy Class: A++
- Water Consumption: 12 lt.
- Antibacterial Filter
- Sound Level: 49 dB(A)
- Active Drying System
- N. 2 Racks
- Overflow & Leakage Protection
- Delay Timer



QW-D41I472X BI Dishwasher Fullsize 60 cm



Key Features

- Capacity: 13 PS
- N. 9 Programmes
- Cabinet Type (60 cm)
- Energy Class: A++
- Water Consumption: 9 lt.
- Antibacterial Filter
- Sound Level: 47 dB(A)
- Active Drying System
- N. 2 Racks
- Overflow & Leakage Protection
- Delay Timer



Installation / Slimline 45 cm

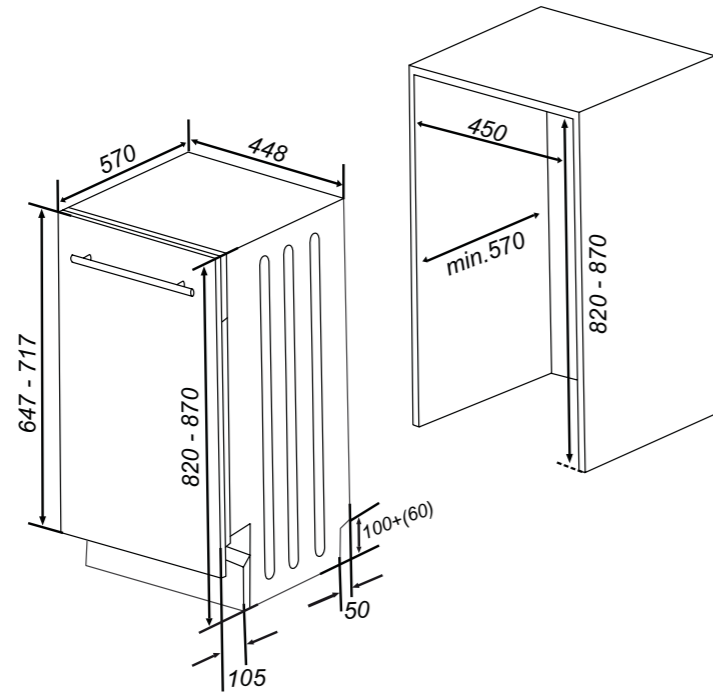

Installation / Fullsize 60 cm

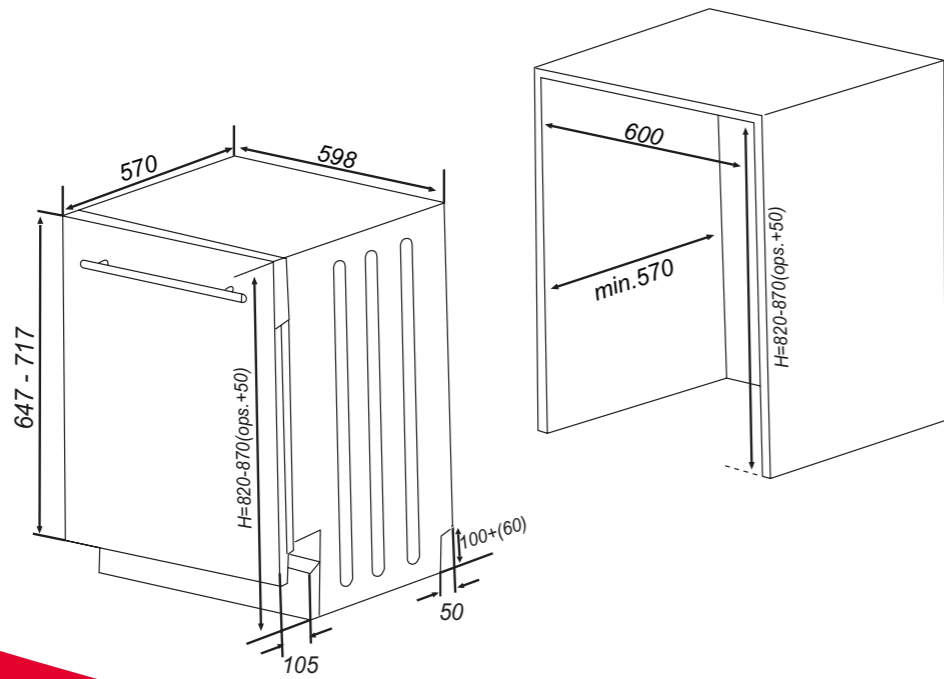

Specifications / Fridge



MODEL NAME	UNIT	SJ-L1300E00X	SJ-L2300E00X	SJ-L2300E01X	SJ-S1197E00X	SJ-S2197E00X	SJ-S2197E01X
Description		Single Door Built-in Larder	Single Door Built-in Larder	Single Door Built-in Larder	Single Door Built-in Freezer	Single Door Built-in Freezer	Single Door Built-in Freezer
Climatic Class		ST/SN	ST/SN	ST/SN	T/SN	ST/SN	ST/SN
Energy Class		A+	A++	A++	A+	A++	A++
Refrigeration System		Static	Static	Static	No Frost	No Frost	No Frost
Control System		Electronic	Electronic	Electronic	Electronic	Electronic	Electronic
Performance	star rating	-	-	-	4	4	4
Household Refrigerating App Categories		1	1	1	8	8	8
Volume Total (gross)	L	303	303	303	221	221	221
Volume Total (net)	L	300	300	300	197	197	197
Volume Refrigerator (gross)	L	303	303	303	-	-	-
Volume Refrigerator Total (net)	L	300	300	300	-	-	-
Volume Freezer (gross)	L	-	-	-	221	221	221
Volume Freezer (net)	L	-	-	-	197	197	197
Energy Consumption	kWh/24h	0.386	0.304	0.304	0.813	0.608	0.608
Energy Consumption	kWh/year	141	111	111	297	222	222
Freezing Capacity	kg/24h	-	-	-	15	15	15
Temperature Rise Time (-18°Cto-9°C)	mins	-	-	-	540	540	540
Temperature Rise Time (-18°C to -9°C)	h	-	-	-	9	9	9
Noise Emission	dB(A)	39	39	39	41	41	41
Defrost System Type Frigde/Freezer		Manual	Manual	Manual	Automatic	Automatic	Automatic
Product Dimensions (WxDxH)	mm	540x545x1770	540x545x1770	540x545x1770	540x545x1770	540x545x1770	540x545x1770
Packaged Dimensions (WxDxH)	mm	584x600x1834	584x600x1834	584x600x1834	584x600x1834	584x600x1834	584x600x1834
Refrigerating Gas		R600A	R600A	R600A	R600A	R600A	R600A
Refrigerating Gas Quantity	gr	36	31	31	44	44	44
Power	W	92	92	92	168	168	168
Defrost Heater Power	W	-	-	-	207	207	207
Current	A	0.41	0.41	0.41	1.16	1.16	1.16
Number of Doors	pcs	1	1	1	1	1	1
Number of Compressors	pcs	1	1	1	1	1	1
Bottle Shelf	pcs	1	1	1	-	-	-
Door Shelf	pcs	4	4	4	-	-	-
Ice Tray	pcs	-	-	-	●	●	●
Chiller Compartment	pcs	-	-	-	-	-	-
Product Weight	kg	53.34	48.8	48.8	58.78	58.6	58.6
Packaged Weight	kg	57.34	52.8	52.8	62.78	62.6	62.6
Condenser Type		Static	Static	Static	Static	Static	Static
Air Flow Type (refrigerator/freezer)		Natural/Natural	Natural/Natural	Natural/Natural	Natural/Natural	Natural/Natural	Natural/Natural
Thermostat	pcs	-	-	-	-	-	-
Sensor	pcs	1	1	1	2	2	2
Packaging Carton Weight (double-wave)	kg	2.84	2.84	2.84	2.84	2.84	2.84
Packaging EPS Weight	kg	1.15	1.15	1.15	1.15	1.15	1.15
Packaging Plastic Bag Weight (PE)	kg	0.22	0.22	0.22	0.22	0.22	0.22
Packaging Strap Weight (PP)	kg	0.037	0.037	0.037	0.037	0.037	0.037
Packaging Tape Weight (PP)	kg	0.0012	0.0012	0.0012	0.0012	0.0012	0.0012
Packaging Tape Weight (PVC)	kg	0.01	0.01	0.01	0.01	0.01	0.01
Packaging Staple Weight (steel)	kg	0.005	0.005	0.005	0.005	0.005	0.005
PU Automation No		17	17	17	20	20	20

Specifications / Fridge



MODEL NAME	UNIT	SJ-B1237M00X	SJ-B2237M01X	SJ-B1243M00X	SJ-B1243M01X	SJ-B1227M00X	SJ-T1214M0X
Description		Double Door Built-in Bottom Freezer	Double Door Built-in Bottom Freezer	Double Door Built-in Bottom Freezer	Double Door Built-in Bottom Freezer	Double Door Built-in Bottom Freezer	Double Door Built-in Top Freezer
Climatic Class		ST/N	T/N	ST/N	ST/N	ST/N	N
Energy Class		A+	A++	A+	A+	A+	A+
Refrigeration System		Frost Free	Frost Free	Static	Static	Frost Free	Static
Control System		Mechanical	Mechanical	Mechanical	Mechanical	Mechanical	Mechanical
Performance	star rating	4	4	4	4	4	4
Household Refrigerating App Categories		7	7	7	7	7	7
Volume Total (gross)	L	256	256	256	256	249	217
Volume Total (net)	L	243	243	251	251	233	214
Volume Refrigerator (gross)	L	181	181	181	181	148	179
Volume Refrigerator Total (net)	L	180	180	181	181	147	176
Volume Freezer (gross)	L	75	75	75	75	101	38
Volume Freezer (net)	L	63	63	70	70	86	38
Energy Consumption	kWh/24h	0.75	0.619	0.736	0.736	0.78	0.622
Energy Consumption	kWh/year	274	226	269	269	285	227
Freezing Capacity	kg/24h	3	3	4	4	3	2
Temperature Rise Time (-18°Cto-9°C)	mins	720	720	1120	1120	780	960
Temperature Rise Time (-18°C to -9°C)	h	12	12	18	18	13	16
Noise Emission	dB(A)	41	TBD	38	38	43	40
Defrost System Type Frigde/Freezer		Automatic	Automatic	Automatic	Automatic	Automatic	Automatic/Manual
Product Dimensions (WxDxH)	mm	540x545x1770	540x545x1770	540x545x1770	540x545x1770	540x545x1770	540x545x1445
Packaged Dimensions (WxDxH)	mm	584x600x1834	584x600x1834	584x600x1834	584x600x1834	584x600x1834	584x600x1509
Refrigerating Gas		R600A	R600A	R600A	R600A	R600A	R600A
Refrigerating Gas Quantity	gr	32	33	72	72	40	48
Power	W	132	132	164	164	150	132
Defrost Heater Power	W	153	153	-	-	153	-
Current	A	0.6	0.6	0.73	0.73	0.66	0.58
Number of Doors	pcs	2	2	2	2	2	2
Number of Compressors	pcs	1	1	1	1	1	1
Bottle Shelf	pcs	1	1	1	1	1	1
Door Shelf	pcs	3	3	3	3	2	3
Ice Tray	pcs	●	●	●	●	●	●
Chiller Compartment	pcs	-	-	-	-	-	-
Product Weight	kg	51	51	51.9	51.9	52.1	38.3
Packaged Weight	kg	55.3	55.3	56.2	56.2	56.4	42.5
Condenser Type		Static	Static	Static	Static	Static	Static
Air Flow Type (refrigerator/freezer)		-	-	-	-	Natural/Natural	Natural/Natural
Thermostat	pcs	-	-	-	-	1 (Outside)	1 (Inside)
Sensor	pcs	-	-	-	-	-	-
Packaging Carton Weight (double-wave)	kg	2.84	2.84	2.84	2.84	2.84	1.85
Packaging EPS Weight	kg	1.15	1.15	1.15	1.15	1.15	0.87
Packaging Plastic Bag Weight (PE)	kg	0.22	0.22	0.22	0.22	0.22	0.13
Packaging Strap Weight (PP)	kg	0.037	0.037	0.037	0.037	0.037	0.037
Packaging Tape Weight (PP)	kg	0.0012	0.0012	0.0012	0.0012	0.0012	0.0012
Packaging Tape Weight (PVC)	kg	0.01	0.01	0.01	0.01	0.01	0.01
Packaging Staple Weight (steel)	kg	0.005	0.005	0.005	0.005	0.005	0.005
PU Automation No		9	9	9	9	10	62

Specifications / Fridge



MODEL NAME	UNIT	SJ-T2214M0X	SJ-T2214M1X	SJ-L1192M0X	SJ-L2204M0X	SJ-L2160M0X	SJ-L1134M0X
Description		Double Door Built-in Top Freezer	Double Door Built-in Top Freezer	Single Door Built-in Fridge	Single Door Built-in Larder	Single Door Built-in Larder	Single Door Built-in Larder
Climatic Class		N	N	N	N	N	T/N
Energy Class		A++	A++	A+	A++	A++	A+
Refrigeration System		Static	Static	Static	Static	Static	Static
Control System		Mechanical	Mechanical	Mechanical	Mechanical	Mechanical	Mechanical
Performance	star rating	4	4	4	-	-	-
Household Refrigerating App Categories		7	7	7	1	1	1
Volume Total (gross)	L	217	217	195	206	162	135
Volume Total (net)	L	214	214	192	204	160	134
Volume Refrigerator (gross)	L	179	179	178	206	162	135
Volume Refrigerator Total (net)	L	176	176	175	204	160	134
Volume Freezer (gross)	L	38	38	17	-	-	-
Volume Freezer (net)	L	38	38	17	-	-	-
Energy Consumption	kWh/24h	0.488	0.488	0.573	0.346	0.261	0.332
Energy Consumption	kWh/year	178	178	209	126	95	121
Freezing Capacity	kg/24h	2	2	2	-	-	-
Temperature Rise Time (-18°Cto-9°C)	mins	960	960	664	-	-	-
Temperature Rise Time (-18°C to -9°C)	h	16	16	11	-	-	-
Noise Emission	dB(A)	40	40	42	39	41	39
Defrost System Type Fridge/Freezer		Automatic/Manual	Automatic/Manual	Automatic/Manual	Automatic	Automatic	Automatic
Product Dimensions (WxDxH)	mm	540x545x1445	540x545x1445	540x545x1225	540x545x1225	540x545x1020	540x545x875
Packaged Dimensions (WxDxH)	mm	584x600x1509	584x600x1509	584x600x1289	584x600x1289	584x600x1084	584x600x939
Refrigerating Gas		R600A	R600A	R600A	R600A	R600A	R600A
Refrigerating Gas Quantity	gr	64	64	42	34	22	26
Power	W	132	132	153	112	58	88
Defrost Heater Power	W	-	-	-	-	-	-
Current	A	0.58	0.58	0.6	0.49	0.27	0.57
Number of Doors	pcs	2	2	1	1	1	1
Number of Compressors	pcs	1	1	1	1	1	1
Bottle Shelf	pcs	1	1	1	1	1	1
Door Shelf	pcs	3	3	3	3	3	2
Ice Tray	pcs	●	●	●	-	-	-
Chiller Compartment	pcs	-	-	-	-	-	-
Product Weight	kg	44.5	44.5	37.5	37.15	29	29.18
Packaged Weight	kg	48.7	48.7	40.82	40.64	32	31.88
Condenser Type		Static	Static	Static	Static	Static	Static
Air Flow Type (refrigerator/freezer)		Natural/Natural	Natural/Natural	Natural	Natural	Natural	Natural
Thermostat	pcs	1 (Inside)	1 (Inside)	1 (Inside)	1 (Inside)	1 (Outside)	1 (Outside)
Sensor	pcs	-	-	-	-	-	-
Packaging Carton Weight (double-wave)	kg	1.85	1.85	2.15	2.2	2.01	1.68
Packaging EPS Weight	kg	0.87	0.87	0.97	1.02	0.97	0.85
Packaging Plastic Bag Weight (PE)	kg	0.13	0.13	0.15	0.15	0.138	0.14
Packaging Strap Weight (PP)	kg	0.037	0.037	0.037	0.037	0.037	0.037
Packaging Tape Weight (PP)	kg	0.0012	0.0012	0.0012	0.0012	0.0012	0.0012
Packaging Tape Weight (PVC)	kg	0.01	0.01	0.01	0.01	0.01	0.01
Packaging Staple Weight (steel)	kg	0.005	0.005	0.005	0.005	0.005	0.005
PU Automation No		62	62	59	53	12	54

Specifications / Fridge



MODEL NAME	UNIT	SJ-L2134M0X	SJ-L2134M1X	SJ-S1099M0X	SJ-S1099M1X	SJ-L1123M1X	SJ-L2123M1X
Description		Single Door Built-in Larder	Single Door Built-in Larder	Single Door Built-in Freezer	Single Door Built-in Freezer	Single Door Built-in Fridge	Single Door Built-in Fridge
Climatic Class		N	N	ST/N	ST/N	N	N
Energy Class		A++	A++	A+	A+	A+	A++
Refrigeration System		Static	Static	Static	Static	Static	Static
Control System		Mechanical	Mechanical	Mechanical	Mechanical	Mechanical	Mechanical
Performance	star rating	-	-	4	4	4	4
Household Refrigerating App Categories		1	1	8	8	7	7
Volume Total (gross)	L	135	135	109	109	126	126
Volume Total (net)	L	134	134	99	99	123	123
Volume Refrigerator (gross)	L	135	135	-	-	109	109
Volume Refrigerator Total (net)	L	134	134	-	-	106	106
Volume Freezer (gross)	L	-	-	109	109	17	17
Volume Freezer (net)	L	-	-	99	99	17	17
Energy Consumption	kWh/24h	0.255	0.255	0.534	0.534	0.499	0.392
Energy Consumption	kWh/year	93	93	195	195	182	143
Freezing Capacity	kg/24h	-	-	8	8	2	2
Temperature Rise Time (-18°Cto-9°C)	mins	-	-	660	660	650	650
Temperature Rise Time (-18°C to -9°C)	h	-	-	11	11	10	10
Noise Emission	dB(A)	39	39	39	39	41	41
Defrost System Type Fridge/Freezer		Automatic	Automatic	Manual	Manual	Automatic/Manual	Automatic/Manual
Product Dimensions (WxDxH)	mm	540x545x875	540x545x875	540x545x875	540x545x875	540x545x875	540x545x875
Packaged Dimensions (WxDxH)	mm	584x600x939	584x600x939	584x600x939	584x600x939	584x600x939	584x577x939
Refrigerating Gas		R600A	R600A	R600A	R600A	R600A	R600A
Refrigerating Gas Quantity	gr	26	26	54	54	36	36
Power	W	88	88	120	120	134	134
Defrost Heater Power	W	-	-	-	-	-	-
Current	A	0.39	0.39	0.5	0.5	0.62	0.62
Number of Doors	pcs	1	1	1	1	1	1
Number of Compressors	pcs	1	1	1	1	1	1
Bottle Shelf	pcs	1	1	-	-	1	1
Door Shelf	pcs	2	2	-	-	2	2
Ice Tray	pcs	-	-	●	●	●	●
Chiller Compartment	pcs	-	-	-	-	-	-
Product Weight	kg	29.18	29.18	36.19	36.19	29.78	29.78
Packaged Weight	kg	31.88	31.88	38.78	38.78	32.8	32.8
Condenser Type		Static	Static	Static	Static	Static	Static
Air Flow Type (refrigerator/freezer)		Natural	Natural	Natural	Natural	Natural	Natural
Thermostat	pcs	1 (Outside)	1 (Outside)	1 (Outside)	1 (Outside)	1 (Outside)	1 (Outside)
Sensor	pcs	-	-	-	-	-	-
Packaging Carton Weight (double-wave)	kg	1.68	1.68	1.98	1.98	1.98	1.98
Packaging EPS Weight	kg	0.85	0.85	0.87	0.87	0.87	0.44
Packaging Plastic Bag Weight (PE)	kg	0.14	0.14	0.13	0.13	0.13	0.13
Packaging Strap Weight (PP)	kg	0.037	0.037	0.037	0.037	0.037	0.037
Packaging Tape Weight (PP)	kg	0.0012	0.0012	0.0012	0.0012	0.0012	0.0012
Packaging Tape Weight (PVC)	kg	0.01	0.01	0.01	0.01	0.01	0.01
Packaging Staple Weight (steel)	kg	0.005	0.005	0.005	0.005	0.005	0.005
PU Automation No		54	54	57	57	56	56

Specifications / BI Oven



MODEL NAME	UNIT	KS-73S56BSS	KS-70S50BSS KS-70S50ISS KS-70S50ASS
Cleaning type		Steam Cleaning	Catalytic
Heat type		Multifunction	Multifunction
Width	cm	60	60
Cavity volume	lt	78	78
Colour		Black	Black/Inox (AntiFingerprint) /Dark Inox
Energy Efficiency Class		A	A
Control type		Electronic	Electronic
Timer type		Colour TFT Timer	Colour TFT Timer
ColourLCD		●	●
Oven opening		Drop-down door	Drop-down door
Door type (Nbr of glass door)	Nbr	Full glass door (3)	Full glass door (3)
Removable inner door glass		●	●
Rack type		Wire rack	Wire rack
Number of shelf levels		5	5
Handle		Inox	Inox
Knob type		Click to Select	Click to Select
Cavity inner surface		Grey enamel	Grey enamel + Catalytic back panel
Number of functions		10	10
Oven functions		Ovenlight, Defrost, Top+Bottom+Fan+Ring, Top+Bottom, Top+Bottom+Fan, Pizza, Grill+Turnspit, Double Grill+Turnspit, Double Grill+Fan+Turnspit, VapCleanplus, Steam Assisted Cooking	Ovenlight, Defrost, Top+Bottom+Fan+Ring, Top+Bottom, Top+Bottom+Fan, Pizza, Grill+Turnspit, Double Grill+Turnspit, Double Grill+Fan+Turnspit, VapClean
VapClean		●	●
AutoCooking Programs	Nbr	● (150)	● (150)
PowerBoost		●	●
Temperature range	°C	50-275	50-275
Cooling Fan		●	●
ActiveCool technology		-	-
Door Lock		-	-
Oven Light		● (Top)	● (Top + Sides)
SoftClosingDoor		●	●
Telescopic Rails		1 set of full telescopic rails	1 set of full telescopic rails
RoastPro Meat Probe		●	●
RoastPro Turnspit		●	●
DoorSwitch		-	●
Pizza Set		● (optional)	● (optional)
Grid	Nbr	1	1
Tray	Nbr	3 (1 shallow, 1 deep, 1 small)	3 (1 shallow, 1 deep, 1 small)
Grill Pan Handle Set		For UK models	For UK models
Main cable	m	● (1.6 m)	● (1.6 m)
Oven dimensions (WxHxD)	cm	59.5 x 59.5 x 57.5	59.5 x 59.5 x 57.5
Cavity dimensions (WxHxD)	cm	45 x 41.3 x 39.2	45 x 41.3 x 39.2
Cut-out dimensions (WxHxD)	cm	58 x 59 x 55.5	58 x 59 x 55.5
Brutto dimensions (WxHxD)	cm	68 x 64 x 63	68 x 64 x 63
Net weight	kg	36	36
Gross Weight	kg	38.7	38.7
Total power	W	3100	3100
Top heating element	W	1200	1200
Bottom heating element	W	1100	1100
Grill	W	1400	1400
Double Grill	W	1400-2600	1400-2600
Fan	W	23	23
Fan with Fan Ring	W	2000	2000
Energy consumption - static	kWh/cycle	0,99	0,99
Energy consumption - fan forced	kWh/cycle	0,93	0,93
Voltage / Frequency	V / Hz	220-240 / 50	220-240 / 50
Fuse rating	A	13.5	13.5

Specifications / BI Oven



MODEL NAME	UNIT	K-71V28IM2 K-71V28AM2 K-71V28BM2	K-70V19BM2 K-70V19IM2 K-70V19AM2	K-70V51IM2	K-70F19BM2
Cleaning type		Pyrolytic	Catalytic	Catalytic	Catalytic
Heat type		Multifunction	Multifunction	Multifunction	Multifunction
Width	cm	60	60	60	60
Cavity volume	lt	78	78	78	78
Colour		Black/Inox (AntiFingerprint) Dark Inox	Black/Inox (AntiFingerprint) Dark Inox	Inox (AntiFingerprint)	Black
Energy Efficiency Class		A	A	A	A
Control type		Electronic	Electronic	Electronic	Electronic
Timer type		Touch + Timer	Touch + Timer	Touch + Timer	LED Full Touch + Timer
ColourLCD		-	-	-	-
Oven opening		Drop-down door	Drop-down door	Drop-down door	Drop-down door
Door type (Nbr of glass door)	Nbr	Full glass door (4)	Full glass door (3)	Full glass door (3)	Full glass door (3)
Removable inner door glass		●	●	●	●
Rack type		Wire rack	Wire rack	Wire rack	Wire rack
Number of shelf levels		5	5	5	5
Handle		Inox	Inox	Inox	Inox
Knob type		PIPO	PIPO	PIPO	-
Cavity inner surface		Pyrolytic enamel	Grey enamel + Catalytic back panel	Grey enamel + Catalytic back panel	Grey enamel + Catalytic back panel
Number of functions		8	9	10	9
Oven functions		Defrost, Top+Bottom, Top+Bottom+Fan, Grill, Double Grill, Pyrolysis, Double Grill+Fan, Top+Bottom+Fan+Ring	Ovenlight, Defrost, Top+Bottom, Top+Bottom+Fan, Bottom+Fan, Grill, Double Grill, Double Grill+Fan, Fan+Ring	Ovenlight, Defrost, Top+Bottom, Top+Bottom+Fan, Bottom+Fan, Grill, Double Grill, Double Grill+Fan, Fan+Ring, Vap clean	Ovenlight, Defrost, Top+Bottom, Top+Bottom+Fan, Bottom+Fan, Grill, Double Grill, Double Grill+Fan, Fan+Ring
VapClean		-	-	●	-
AutoCooking Programs	Nbr	-	-	-	-
PowerBoost		-	-	-	-
Temperature range	°C	50-270	50-270	50-270	50-270
Cooling Fan		●	●	●	●
ActiveCool technology		●	-	-	-
Door Lock		●	-	-	-
Oven Light		● (Top + Sides)	● (Top)	● (Top)	● (Top)
SoftClosingDoor		●	-	-	-
Telescopic Rails		1 set of full telescopic rails	1 set of standard telescopic rails	1 set of standard telescopic rails	1 set of standard telescopic rails
RoastPro Meat Probe		-	-	-	-
RoastPro Turnspit		-	-	-	-
DoorSwitch		●	-	-	-
Pizza Set		● (optional)	● (optional)	● (optional)	● (optional)
Grid	Nbr	1	1	1	1
Tray	Nbr	2 (1 shallow, 1 deep)	3 (1 shallow, 1 deep, 1 small)	3 (1 shallow, 1 deep, 1 small)	2 (1 shallow, 1 deep, 1 small)
Grill Pan Handle Set		For UK models	For UK models	For UK models	For UK models
Main cable	m	● (1.6 m)	● (1.6 m)	● (1.6 m)	● (1.6 m)
Oven dimensions (WxHxD)	cm	59.5 x 59.5 x 57.5	59.5 x 59.5 x 57.5	59.5 x 59.5 x 57.5	59.5 x 59.5 x 57.5
Cavity dimensions (WxHxD)	cm	45 x 41.3 x 39.2	45 x 41.3 x 39.2	45 x 41.3 x 39.2	45 x 41.3 x 39.2
Cut-out dimensions (WxHxD)	cm	58 x 59 x 55.5	58 x 59 x 55.5	58 x 59 x 55.5	58 x 59 x 55.5
Brutto dimensions (WxHxD)	cm	68 x 64 x 63	68 x 64 x 63	68 x 64 x 63	68 x 64 x 63
Net weight	kg	36	36	36	36
Gross Weight	kg	38.7	38.7	38.7	38.7
Total power	W	3100	3100	3100	3100
Top heating element	W	1200	1200	1200	1200
Bottom heating element	W	1100	1100	1100	1100
Grill	W	1400	1400	1400	1400
Double Grill	W	1400-2600	1400-2600	1400-2600	1400-2600
Fan	W	23	23	23	23
Fan with Fan Ring	W	2000	2000	2000	2000
Energy consumption - static	kWh/cycle	0,99	0,99	0,99	0,99
Energy consumption - fan forced	kWh/cycle	0,93	0,93	0,93	0,93
Voltage / Frequency	V / Hz	220-240 / 50	220-240 / 50	220-240 / 50	220-240 / 50
Fuse rating	A	13.5	13.5	13.5	13.5

Specifications / BI Oven



MODEL NAME	UNIT	KS-70T50BHH	K-61D27BM1 K-61D27IM1	K-61V28BM1 K-61V28IM1	K-60V19BQM K-60V19IQM
Cleaning type		Catalytic	Pyrolytic	Pyrolytic	Catalytic Cleaning
Heat type		Multifunction	Fan assisted	Multifunction	Multifunction
Width	cm	60	60	60	60
Cavity volume	lt	78	68	68	69
Colour		Black	Black/Inox (AntiFingerprint)	Black/Inox (AntiFingerprint)	Black/Inox (AntiFingerprint)
Energy Efficiency Class		A	A	A	A
Control type		Electronic	Electronic	Electronic	Electronic
Timer type		Monochrome TFT Timer	Digital Timer	Touch + Timer	Touch + Timer
ColourLCD		-	-	-	-
Oven opening		Drop-down door	Drop-down door	Drop-down door	Drop-down door
Door type (Nbr of glass door)	Nbr	Full glass door (3)	Full glass door (4)	Full glass door (4)	Full glass door (3)
Removable inner door glass		●	●	●	●
Rack type		Wire rack	Wire rack	Wire rack	Wire rack
Number of shelf levels		5	5	5	5
Handle		Inox	Inox	Inox	Inox
Knob type		NA	PIPO	PIPO	PIPO
Cavity inner surface		Grey enamel + Catalytic back panel	Pyrolytic enamel	Pyrolytic enamel	Grey enamel
Number of functions		10	6	8	9
Oven functions		Ovenlight, Defrost, Top+Bottom+Fan+Ring, Top+Bottom, Top+Bottom+Fan, Pizza, Grill+Turnspit, Double Grill+Turnspit, Double Grill+Fan+Turnspit, VapClean	Defrost, Top+Bottom, Top+Bottom+Fan, Grill, Double Grill, Pyrolysis	Defrost, Top+Bottom, Top+Bottom+Fan, Grill, Double Grill, Pyrolysis, Double Grill+Fan, Top+Bottom+Fan+Ring	Ovenlight, Defrost, Top+Bottom, Top+Bottom+Fan, Bottom+Fan, Grill, Double Grill, Double Grill+Fan, Fan+Ring
VapClean		●	-	-	-
AutoCooking Programs	Nbr	50	-	-	-
PowerBoost		●	-	-	-
Temperature range	°C	50-275	50-250	50-270	50-270
Cooling Fan		●	●	●	●
ActiveCool technology		-	●	●	-
Door Lock		-	●	●	-
Oven Light		● (Top + Sides)	● (Top)	● (Top)	● (Top)
SoftClosingDoor		●	-	-	-
Telescopic Rails		1 set of full telescopic rails	-	-	-
RoastPro Meat Probe		-	-	-	-
RoastPro Turnspit		●	-	-	-
DoorSwitch		●	●	●	-
Pizza Set		● (optional)	● (optional)	● (optional)	● (optional)
Grid	Nbr	1	1	1	1
Tray	Nbr	3 (1 shallow, 1 deep, 1 small)	2 (1 shallow, 1 deep)	2 (1 shallow, 1 deep)	2 (1 shallow, 1 deep)
Grill Pan Handle Set		For UK models	For UK models	For UK models	For UK models
Main cable	m	● (1.6 m)	● (1.6 m)	● (1.6 m)	● (1.6 m)
Oven dimensions (WxHxD)	cm	59.5 x 59.5 x 57.5	59.5 x 59.5 x 57.5	59.5 x 59.5 x 57.5	59.5 x 59.5 x 57.5
Cavity dimensions (WxHxD)	cm	45 x 41.3 x 39.2	45 x 35.1 x 35.2	45 x 35.1 x 35.2	45 x 35.1 x 35.2
Cut-out dimensions (WxHxD)	cm	58 x 59 x 55.5	58 x 59 x 55.5	58 x 59 x 55.5	58 x 59 x 55.5
Brutto dimensions (WxHxD)	cm	68 x 64 x 63	68 x 64 x 63	68 x 64 x 63	68 x 64 x 63
Net weight	kg	36	34.3	37.1	28.2
Gross Weight	kg	38.7	37	39.8	30.9
Total power	W	3100	2600	2600	3100
Top heating element	W	1200	1200	1200	1200
Bottom heating element	W	1100	1100	1100	1100
Grill	W	1400	1400	1400	1400
Double Grill	W	1400-2600	1400-2600	1400-2600	1400-2600
Fan	W	23	23	23	23
Fan with Fan Ring	W	2000	-	2000	2000
Energy consumption - static	kWh/cycle	0.99	0.98	0.98	0.99
Energy consumption - fan forced	kWh/cycle	0.93	0.87	0.87	0.93
Voltage / Frequency	V / Hz	220-240 / 50	220-240 / 50	220-240 / 50	220-240 / 50
Fuse rating	A	13.5	11.3	11.3	13.5

Specifications / BI Oven



MODEL NAME	UNIT	K-70F19BQM	K-60D22BM1 K-60D22IM1	K-50M15BL2 K-50M15IL2	K-50M22BL2 K-50M22IL2
Cleaning type		Catalytic	Manual	Manual	Manual
Heat type		Multifunction	Fan assisted	Static	Fan assisted
Width	cm	60	60	60	60
Cavity volume	lt	78	69	64	65
Colour		Black	Black/Inox (AntiFingerprint)	Black/Inox (AntiFingerprint)	Black/Inox (AntiFingerprint)
Energy Efficiency Class		A	A	A	A
Control type		Electronic	Electronic	Mechanical	Mechanical
Timer type		LED Full Touch+ Timer	Touch Timer	Mechanical Timer	Mechanical Timer
ColourLCD		-	-	-	-
Oven opening		Drop-down door	Drop-down door	Drop-down door	Drop-down door
Door type (Nbr of glass door)	Nbr	Full glass door (3)	Profile door with big inner glass (2)	Profile door with big inner glass (2)	Profile door with big inner glass (2)
Removable inner door glass		●	●	-	-
Rack type		Wire rack	Wire rack	Molded rack	Molded rack
Number of shelf levels		5	5	5	5
Handle		Inox	Inox	Inox	Inox
Knob type		-	PIPO	-	PIPO
Cavity inner surface		Grey enamel + Catalytic back panel	Grey enamel	Grey enamel	Grey enamel
Number of functions		9	8	6	8
Oven functions		Ovenlight, Defrost, Top+Bottom, Top+Bottom+Fan, Bottom+Fan, Grill, Double Grill+Fan, Fan+Ring	Ovenlight, Defrost, Top+Bottom, Top+Bottom+Fan, Bottom+Fan, Grill, Double Grill, Double Grill+Fan	Top, Ovenlight, Top+Bottom, Bottom, Grill, Double Grill	Ovenlight, Defrost, Top+Bottom, Top+Bottom+Fan, Bottom+Fan, Grill, Double Grill, Double Grill+Fan
VapClean		-	-	-	-
AutoCooking Programs	Nbr	-	-	-	-
PowerBoost		-	-	-	-
Temperature range	°C	50-270	50-270	50-270	50-270
Cooling Fan		●	●	●	●
ActiveCool technology		-	-	-	-
Door Lock		-	-	-	-
Oven Light		● (Top)	● (Top)	● (Top)	● (Top)
SoftClosingDoor		-	-	-	-
Telescopic Rails		1 set of standard telescopic rails	-	-	-
RoastPro Meat Probe		-	-	-	-
RoastPro Turnspit		-	-	-	-
DoorSwitch		-	-	-	-
Pizza Set		● (optional)	● (optional)	● (optional)	● (optional)
Grid	Nbr	1	1	1	1
Tray	Nbr	2 (1 shallow, 1 deep, 1 small)	2 (1 shallow, 1 deep)	2 (1 shallow, 1 deep)	2 (1 shallow, 1 deep)
Grill Pan Handle Set		For UK models	For UK models	For UK models	For UK models
Main cable	m	● (1.6 m)	● (1.6 m)	● (1.6 m)	● (1.6 m)
Oven dimensions (WxHxD)	cm	59.5 x 59.5 x 57.5	59.5 x 59.5 x 57.5	59.5 x 59.5 x 57.5	59.5 x 59.5 x 57.5
Cavity dimensions (WxHxD)	cm	45 x 41.3 x 39.2	45 x 35.1 x 35.2	43 x 39.1 x 33.5	45 x 35.1 x 35.2
Cut-out dimensions (WxHxD)	cm	58 x 59 x 55.5	58 x 59 x 55.5	58 x 59 x 55.5	58 x 59 x 55.5
Brutto dimensions (WxHxD)	cm	68 x 64 x 63	68 x 64 x 63	68 x 64 x 63	68 x 64 x 63
Net weight	kg	36	28.2	29.7	29.7
Gross Weight	kg	38.7	30.9	32.4	32.4
Total power	W	3100	2600	2600	2600
Top heating element	W	1200	1200	1200	1200
Bottom heating element	W	1100	1100	1100	1100
Grill	W	1400	1400	1400	1400
Double Grill	W	1400-2600	1400-2600	1400-2600	1400-2600
Fan	W	23	23	-	-
Fan with Fan Ring	W	2000	-	-	-
Energy consumption - static	kWh/cycle	0.99	0.98	0.85	0.85
Energy consumption - fan forced	kWh/cycle	0.93	0.87	-	-
Voltage / Frequency	V / Hz	220-240 / 50	220-240 / 50	220-240 / 50	220-240 / 50
Fuse rating	A	13.5	11.3	11.3	11.3

Specifications / BI Induction Hob



MODEL NAME	UNIT	KH-9I26CT00	KH-6I27CS00	KH-7I19CS00	KH-7I18CT00
Hob type		Induction	Induction	Induction	Induction
Width	cm	90	60	78	78
Colour		Black	Black	Black	Black
Cooking zones	Nbr	5	4	4	4
Flexible zone		-	CookBridge	-	-
Zone dimensions / Power / Boost	Nbr x cm / W / W	2 x 16 / 1400 / 1800 2 x 20 / 2100 / 2500 1 x 25 / 2800 / 3500	3 x 16 / 1400 / 1800 1 x 21 / 2100 / 2500 Cookbridge 35.4 x 16 / 2800 / 3600	2 x 16 / 1400 / 1800 2 x 20 / 2100 / 2500	2 x 16 / 1400 / 1800 2 x 20 / 2100 / 2500
Total power	kW	10,8	7,4	10,8	10,8
Control location		Front	Front	Front	Front
Control type		Touch keys	SliderTouch	SliderTouch	Touch keys
Power levels	Nbr	9	9	9	9
Frame		-	-	-	-
Bevel		4-side bevel	4-side bevel	4-side bevel	4-side bevel
AutoHeatControl		-	•	-	-
Stop&Go		•	•	•	•
Timers	Nbr	5	4	4	4
InductionBoost	Nbr	5	4	4	4
Pan detector		•	•	•	•
Thermal cut off system		•	•	•	•
Hot surface indicator		•	•	•	•
Key lock		•	•	•	•
Child lock		•	•	•	•
AutoOFF		•	•	•	•
Main cable	m	• (1.1 m)	• (1.1 m)	• (1.1 m)	• (1.1 m)
Spatula		•	•	•	•
Hob dimensions (WxHxD)	cm	89 x 5.6 x 52	59 x 5.6 x 52	77 x 56 x 52	77 x 56 x 52
Cut-out dimensions (WxD)	cm	86 x 49	56 x 49	75 x 49	75 x 49
Brutto dimensions (WxHxD)	cm	92.6 x 14.2 x 58.1	62.6 x 58.1 x 14.2	81.6 x 14.2 x 58.1	81.6 x 14.2 x 58.1
Net weight	kg	16	11	12	12
Brutto weight	kg	17	12	13	13
Voltage / Frequency	V / Hz	220-240 / 50	220-240 / 50	220-240 / 50	220-240 / 50
Fuse rating	A	50	32	50	50

Specifications / BI Induction Hob



MODEL NAME	UNIT	KH-6I34BS00	KH-6I31BS00	KH-6I19BS00	KH-6I19FT00
Hob type		Induction	Induction	Induction	Induction
Width	cm	60	60	60	60
Colour		Black	Black	Black	Black
Cooking zones	Nbr	3	3	4	4
Flexible zone		CookBridge	-	-	-
Zone dimensions / Power / Boost	Nbr x cm / W / W	2 x 16 / 1400 / 1800 1 x 29 / 2800 / 3500	1 x 16 / 1400 / 1800 1 x 21 / 2100 / 2500 1 x 29 / 2800 / 3500	2 x 16 / 1400 / 1800 2 x 21 / 2100 / 2500	2 x 16 / 1400 / 1800 2 x 21 / 2100 / 2500
Total power	kW	7,2	7,2	7,4	7,4
Control location		Front	Front	Front	Front
Control type		SliderTouch	SliderTouch	SliderTouch	Touch keys
Power levels	Nbr	9	9	9	9
Frame		-	-	-	2-side inox frame
Bevel		Front bevel	Front bevel	Front bevel	-
AutoHeatControl		•	•	•	•
Stop&Go		•	•	•	•
Timers	Nbr	3	3	4	4
InductionBoost	Nbr	3	3	4	4
Pan detector		•	•	•	•
Thermal cut off system		•	•	•	•
Hot surface indicator		•	•	•	•
Key lock		•	•	•	•
Child lock		•	•	•	•
AutoOFF		•	•	•	•
Main cable	m	• (1.1 m)	• (1.1 m)	• (1.1 m)	• (1.1 m)
Spatula		•	•	•	•
Hob dimensions (WxHxD)	cm	59 x 5.6 x 52	59 x 5.6 x 52	59 x 5.6 x 52	59 x 5.6 x 52
Cut-out dimensions (WxD)	cm	56 x 49	56 x 49	56 x 49	56 x 49
Brutto dimensions (WxHxD)	cm	62.6 x 14.2 x 58.1	62.6 x 14.2 x 58.1	62.6 x 14.2 x 58.1	62.6 x 14.2 x 58.1
Net weight	kg	11	11	11	11
Brutto weight	kg	12	12	12	12
Voltage / Frequency	V / Hz	220-240 / 50	220-240 / 50	220-240 / 50	220-240 / 50
Fuse rating	A	32	32	32	32

Specifications / BI Vitroceramic Hob



MODEL NAME	UNIT	KH-6V09CS00	KH-6V08BS00	KH-6V13BS00	KH-6V08FT00
Hob type		Vitroceramic	Vitroceramic	Vitroceramic	Vitroceramic
Width	cm	60	60	60	60
Colour		Black	Black	Black	Black
Cooking zones	Nbr	4	4	3	4
Flexible zone		2xZone + Extended2xZone	2xZone	3xZone	2xZone
Zone dimensions / Power	Nbr x cm / W	2 x 14.5 / 1200 1 x 18 2xZone / 1700 1 x 14.5-25.2 Extended2xZone / 1800	2 x 14.5 / 1200 1 x 18 / 1800 1 x 18 2xZone / 1700	2 x 14.5 / 1200 1 x 18 / 1800 1 x 27 3xZone / 2700	2 x 14.5 / 1200 1 x 18 / 1800 1 x 18 2xZone / 1700
Total power	kW	5,9	5,9	5,7	5,9
Control location		Front	Front	Front	Front
Control type		SliderTouch	SliderTouch	SliderTouch	Touch keys
Power levels	Nbr	9	9	9	9
Frame		-	-	-	2-side inox frame
Bevel		4-side bevel	Front bevel	Front bevel	-
AutoHeatControl		-	-	-	-
Stop&Go		-	-	-	-
Timers	Nbr	4	4	3	4
InductionBoost	Nbr	-	-	-	-
Pan detector		-	-	-	-
Thermal cut off system		•	•	•	•
Hot surface indicator		•	•	•	•
Key lock		•	•	•	•
Child lock		•	•	•	•
AutoOFF		•	•	•	•
Main cable	m	• (1.1 m)	• (1.1 m)	• (1.1 m)	• (1.1 m)
Spatula		•	•	•	•
Hob dimensions (WxHxD)	cm	59 x 4.1 x 52	59 x 4.1 x 52	59 x 4.1 x 52	59 x 4.1 x 52
Cut-out dimensions (WxD)	cm	56 x 49	56 x 49	56 x 49	56 x 49
Brutto dimensions (WxHxD)	cm	62 x 13.3 x 57.8	62 x 13.3 x 57.8	62 x 13.3 x 57.8	62 x 13.3 x 57.8
Net weight	kg	9.5	9.5	9.5	9.5
Brutto weight	kg	10.25	10.25	10.25	10.25
Voltage / Frequency	V / Hz	220-240 / 50	220-240 / 50	220-240 / 50	220-240 / 50
Fuse rating	A	25	25	25	25

Specifications / BI Polyvalent



MODEL NAME	UNIT	K-72D19IM2
Cleaning type		Catalytic
Heat type		Multifunction
Combined Poly hob model		KH-6I20FT00
Width	cm	60
Cavity volume	lt	78
Colour		Inox (AntiFingerprint)
Energy Efficiency Class		A
Control type		Electronic
Timer type		Touch Timer
ColourLCD		-
Oven opening		Drop-down door
Door type	Nbr of glass door	Full glass door (3)
Removable inner door glass		•
Rack type		Wire rack
Number of shelf levels		5
Handle		Inox
Knobs		PIPO
Cavity inner surface		Grey enamel + Catalytic back panel
Number of functions		9
Oven functions		Ovenlight, Defrost, Top+Bottom, Top+Bottom+Fan, Bottom+Fan, Grill, Double Grill, Double Grill+Fan, Fan+Ring
VapClean		-
AutoCooking Programs	Nbr	-
PowerBoost		-
Temperature range	°C	50-270
Cooling Fan		•
ActiveCool technology		-
Door Lock		-
Oven Light		• (Top)
SoftClosingDoor		-
Telescopic Rails		1 set of standard telescopic rails
RoastPro Meat Probe		-
RoastPro Turnspit		-
DoorSwitch		-
Pizza Set		• (optional)
Grid	Nbr	1
Tray	Nbr	3 (1 shallow, 1 deep, 1 small)
Grill Pan Handle Set		For UK models
Main cable	m	• (1.6)
Oven dimensions (WxHxD)	cm	59.5 x 59.5 x 57.5
Cavity dimensions (WxHxD)	cm	43 x 39.1 x 33.5
Cut-out dimensions (WxHxD)	cm	58 x 59 x 55.5
Brutto dimensions (WxHxD)	cm	68 x 64 x 63
Net weight	kg	36
Gross Weight	kg	38.7
Total power	W	2600
Top heating element	W	1200
Bottom heating element	W	1100
Grill	W	1400
Double Grill	W	1400-2600
Fan	W	23
Fan with Fan Ring	W	2000
Energy consumption - static	kWh/cycle	0.99
Energy consumption - fan forced	kWh/cycle	0.93
Voltage / Frequency	V / Hz	220-240 / 50
Fuse rating	A	11.30



MODEL NAME	UNIT	KH-6I19FT00
Hob type		Poly-Induction
Combined Poly oven model(s)		K-72D19IM2
Width	cm	60
Colour		Black
Cooking zones	Nbr	4
Flexible zone		-
Zone dimensions / Power / Boost	cm / W / W	2 x 16 / 1400 (Boost 1800) 2 x 20 / 2100 (Boost 2500)
Total power	kW	7.4
Control location		On oven
Power levels	Nbr	9
Frame		4-side inox frame
Bevel		-
AutoHeatControl		-
Stop&Go		•
Timers	Nbr	4
InductionBoost	Nbr	4
Pan detector		•
Thermal cut off system		•
Hot surface indicator		•
Key lock		•
Child lock		•
AutoOFF		•
Main cable	m	• (1.1)
Spatula		•
Hob dimensions (WxHxD)	cm	59 x 5.6 x 52
Cut-out dimensions (WxD)	cm	56 x 49
Brutto dimensions (WxHxD)	cm	62.6 x 14.2 x 58.1
Net weight	kg	11
Brutto weight	kg	12
Voltage / Frequency	V / Hz	220-240 / 50
Fuse rating	A	32

Specifications / BI Polyvalent



MODEL NAME	UNIT	K-62V19IM1
Cleaning type		Manual
Heat type		Multifunction
Combined Poly hob model		KH-6V05FT00
Width	cm	60
Cavity volume	lt	69
Colour		Inox (AntiFingerprint)
Energy Efficiency Class		A
Control type		Electronic
Timer type		Touch+ Timer
ColourLCD		-
Oven opening		Drop-down door
Door type	Nbr of glass door	Profile door with big inner glass (2)
Removable inner door glass		•
Rack type		Wire rack
Number of shelf levels		5
Handle		Inox
Knobs		PIPO
Cavity inner surface		Grey enamel
Number of functions		9
Oven functions		Ovenlight, Defrost, Top+Bottom, Top+Bottom+Fan, Bottom+Fan, Grill, Double Grill, Double Grill+Fan, Fan+Ring
VapClean		-
AutoCooking Programs	Nbr	-
PowerBoost		-
Temperature range	°C	50-270
Cooling Fan		•
ActiveCool technology		-
Door Lock		-
Oven Light		• (Top)
SoftClosingDoor		-
Telescopic Rails		-
RoastPro Meat Probe		-
RoastPro Turnspit		-
DoorSwitch		-
Pizza Set		• (optional)
Grid	Nbr	1
Tray	Nbr	2 (1 shallow, 1 deep)
Grill Pan Handle Set		For UK models
Main cable	m	• (1.6)
Oven dimensions (WxHxD)	cm	59.5 x 59.5 x 57.5
Cavity dimensions (WxHxD)	cm	43 x 39.1 x 33.5
Cut-out dimensions (WxHxD)	cm	58 x 59 x 55.5
Brutto dimensions (WxHxD)	cm	68 x 64 x 63
Net weight	kg	28.2
Gross Weight	kg	30.9
Total power	W	2600
Top heating element	W	1200
Bottom heating element	W	1100
Grill	W	1400
Double Grill	W	1400-2600
Fan	W	23
Fan with Fan Ring	W	2000
Energy consumption - static	kWh/cycle	0.98
Energy consumption - fan forced	kWh/cycle	0.87
Voltage / Frequency	V / Hz	220-240 / 50
Fuse rating	A	11.30



MODEL NAME	UNIT	KH-6V05FT00
Hob type		Poly-Vitroc ceramic
Combined Poly oven model(s)		K-52M15IL2 K-62V19IM1 K-62V19IM0
Width	cm	60
Colour		Black
Cooking zones	Nbr	4
Flexible zone		2xZone
Zone dimensions / Power	cm / W	2 x 14.5 / 1200 1 x 18 / 1800 1 x 18 2xZone / 1700
Total power	kW	5.9
Control location		On oven
Power levels	Nbr	9
Frame		4-side inox frame
Bevel		-
AutoHeatControl		-
Stop&Go		-
Timers	Nbr	4
InductionBoost	Nbr	-
Pan detector		-
Thermal cut off system		•
Hot surface indicator		•
Key lock		•
Child lock		•
AutoOFF		•
Main cable	m	• (1.1)
Spatula		•
Hob dimensions (WxHxD)	cm	59 x 4.1 x 52
Cut-out dimensions (WxD)	cm	56 x 49
Brutto dimensions (WxHxD)	cm	62 x 13.3 x 57.8
Net weight	kg	9.5
Brutto weight	kg	10.25
Voltage / Frequency	V / Hz	220-240 / 50
Fuse rating	A	25

Specifications / BI Polyvalent



MODEL NAME	UNIT	K-52M15IL2
Cleaning type		Manual
Heat type		Static
Combined Poly hob model		KH-6V05FT00
Width	cm	60
Cavity volume	lt	64
Colour		Inox (AntiFingerprint)
Energy Efficiency Class		A
Control type		Mechanical
Timer type		Mechanical Timer
ColourLCD		-
Oven opening		Drop-down door
Door type	Nbr of glass door	Profile door with big inner glass (2)
Removable inner door glass		-
Rack type		Molded rack
Number of shelf levels		5
Handle		Inox
Knobs		REGULAR
Cavity inner surface		Grey enamel
Number of functions		6
Oven functions		Top, Ovenlight, Top+Bottom, Bottom, Grill, Double Grill
VapClean		-
AutoCooking Programs	Nbr	-
PowerBoost		-
Temperature range	°C	50-270
Cooling Fan		•
ActiveCool technology		-
Door Lock		-
Oven Light		• (Top)
SoftClosingDoor		-
Telescopic Rails		-
RoastPro Meat Probe		-
RoastPro Turnspit		-
DoorSwitch		-
Pizza Set		• (optional)
Grid	Nbr	1
Tray	Nbr	2 (1 shallow, 1 deep)
Grill Pan Handle Set		For UK models
Main cable	m	• (1.6)
Oven dimensions (WxHxD)	cm	59.5 x 59.5 x 57.5
Cavity dimensions (WxHxD)	cm	43 x 39.1 x 33.5
Cut-out dimensions (WxHxD)	cm	58 x 59 x 55.5
Brutto dimensions (WxHxD)	cm	68 x 64 x 63
Net weight	kg	29.7
Gross Weight	kg	32.4
Total power	W	2600
Top heating element	W	1200
Bottom heating element	W	1100
Grill	W	1400
Double Grill	W	1400-2600
Fan	W	-
Fan with Fan Ring	W	-
Energy consumption - static	kWh/cycle	0.85
Energy consumption - fan forced	kWh/cycle	-
Voltage / Frequency	V / Hz	220-24 / 50
Fuse rating	A	11.30



MODEL NAME	UNIT	KH-6V05FT00
Hob type		Poly-Vitroc ceramic
Combined Poly oven model(s)		K-52M15IL2 K-62V19IM1 K-62V19IM0
Width	cm	60
Colour		Black
Cooking zones	Nbr	4
Flexible zone		2xZone
Zone dimensions / Power	cm / W	2 x 14.5 / 1200 1 x 18 / 1800 1 x 18 2xZone / 1700
Total power	kW	5.9
Control location		On oven
Power levels	Nbr	9
Frame		4-side inox frame
Bevel		-
AutoHeatControl		-
Stop&Go		-
Timers	Nbr	4
InductionBoost	Nbr	-
Pan detector		-
Thermal cut off system		•
Hot surface indicator		•
Key lock		•
Child lock		•
AutoOFF		•
Main cable	m	• (1.1)
Spatula		•
Hob dimensions (WxHxD)	cm	59 x 4.1 x 52
Cut-out dimensions (WxD)	cm	56 x 49
Brutto dimensions (WxHxD)	cm	62 x 13.3 x 57.8
Net weight	kg	9.5
Brutto weight	kg	10.25
Voltage / Frequency	V / Hz	220-240 / 50
Fuse rating	A	25

Specifications / BI Hood



MODEL NAME	UNIT	KL-612TBSS	KL-611TBMH	KL-910TBMH	KL-610TBLM
Hood type		Wall-mounted	Wall-mounted	Wall-mounted	Wall-mounted
Operating mode		Extraction mode	Extraction mode	Extraction mode	Extraction mode
Convertible to recirculation mode		•	•	•	•
Width	cm	60	60	90	60
Colour		Inox + Black decorative glass	Inox + Black decorative glass	Inox + Black decorative glass	Inox + Black decorative glass
Energy Efficiency Class		A	A	B	B
Lighting Efficiency Class		A	B	B	B
Grease Filtering Efficiency Class		D	D	D	D
Control type		Touch Control on glass	Touch Control on glass	Touch Control on glass	Touch Control on glass
ColourLCD		•	-	-	-
Power levels + boost		4 + 1	4 + 1	4 + 1	4 + 1
Airflow speed 4 / boost	m³/h	570 / 680	548 / 724	495 / 693	495 / 693
Noise level speed 1	dB(A)	46.9	49.5	52.6	52.6
Noise level speed 2	dB(A)	52.9	55.2	52.8	52.8
Noise level speed 3	dB(A)	59.6	61	59.9	59.9
Noise level speed 4	dB(A)	62.4	65.6	63.5	63.5
Noise level boost	dB(A)	65.1	70.6	69	69
Filter Cleaning Signal		•	•	•	•
Timer & Auto turn off in 15 min		•	•	•	•
SteamSensor		•	-	-	-
MotionSensor		-	•	-	-
NightSensor		•	-	-	-
Hood Light		LED light (incl. back light)	LED light (incl. back light)	LED light	LED light
Grease filter	Nbr	1	1	1	1
Washable grease filter in a dishwasher		•	•	•	•
Outlet	mm	150	150	150	150
150-120 mm outlet adaptor		•	•	•	•
Non return valve		•	•	•	•
Main cable	m	• (2)	• (2)	• (2)	• (2)
Hood dimensions (WxHxD)	cm	59.6 x min.75.5-max.113.5 x 34.8	59.8 x min.68.3-max.106.3 x 42.5	89.8 x min.66-max.104 x 49.6	59.8 x min.66-max.104 x 49.6
Brutto dimensions (WxHxD)	cm	100 x 59 x 45	69 x 66 x 46	98 x 54.5 x 55.5	68 x 54.5 x 55.5
Net weight	kg	21.2	19.1	19.2	16.9
Brutto weight	kg	26.4	22.8	24.7	20.3
Total power	W	210	210	275	275
Annual Energy Consumption	kWh	52	56	77	77
Voltage / Frequency	V / Hz	220-240 / 50	220-240 / 50	220-240 / 50	220-240 / 50
Fuse rating	A	16	16	16	16

Specifications / BI Dishwasher Slimline 45 cm



MODEL NAME	UNIT	QW-GS53I443X	QW-GS52I452X	QW-S41I472X	QW-S32I472X	QW-S12I492X
Description		Slimline 45 cm Built-in Dishwasher	Slimline Built-in Dishwasher	Slimline Built-in Dishwasher	Slimline Built-in Dishwasher	Slimline Built-in Dishwasher
KEY FEATURES						
Cleaning Performance		A	A	A	A	A
Drying Performance		A	A	A	A	A
Number of Place Settings		10	10	10	10	10
Number of racks		3	3	3	2	2
Number of Programmes		8	8	8	8	3
Energy Efficiency		A+++	A++	A++	A++	A++
Dishwasher Type		Integrated 45 cm	Integrated 45 cm	Integrated 45 cm	Integrated 45 cm	Integrated 45 cm
WaterBlade & AquaGlide		-	-	-	-	-
Quick Wash Duration	mins	QuickWash 14'	QuickWash 14'	Quick 30'	Quick 30'	-
Drying System		Turbo	Turbo	Turbo	Active	Active
Water Consumption	L	9	9	9	11	11
OTHER FEATURES						
Advanced Inverter Motor		•	-	-	-	-
Graphic Displays		•	•	•	•	-
Built-in Appliance		•	•	•	•	•
IntelliWash		•	•	•	-	-
AutoDoor		•	-	-	-	-
EcoBox		-	-	-	-	-
MicroBan		•	•	•	•	•
Extra Silent Option		•	-	-	-	-
Extra Fast Option		•	-	-	-	-
Adjustable Upper Basket When Empty		Adj. When Loaded	Adj. When Loaded	Adj. When Loaded	Adj. When Empty	Adj. When Empty
Number of Mug Shelves		2 Fixed Mugshelf	2 Fixed Mugshelf	2 Fixed Mugshelf	4 Fixed Mugshelf	4 Fixed Mugshelf
Foldable Racks on Upper Basket		Peg - Fold. Racks	Peg - Fold. Racks	Peg - Fold. Racks	Peg - Fold. Racks	Peg - Fold. Racks
Foldable Racks on Lower Basket		2 Fold. Racks	2 Fold. Racks	2 Fold. Racks	2 Fold. Racks	2 Fold. Racks
DualProWash		•	-	-	-	-
Child Lock		-	-	-	-	-
EcoWash		•	•	•	-	-
HygieneWash		•	•	•	•	-
Express 50		•	•	•	•	-
Thirty Minute Wash		•	•	•	•	-
Delay Timer		•	•	•	•	-
SuperQuiet		-	-	-	-	-
Interior LED Lighting		-	-	-	-	-
Overflow and Leakage Protection		•	•	•	•	•
FlexiTray		•	•	•	-	-
Extra Hygiene Option		-	-	-	-	-
Extra Dry Option		-	-	-	-	-
Half Load Option		• (3 modes)	• (3 modes)	• (3 modes)	•	-
Number of Spray Arms		2 + extra top nozzle	2 + extra top nozzle	2 + extra top nozzle	2 + extra top nozzle	2 + extra top nozzle
Washing Cycle Indicator		-	-	-	-	-
Water Inlet		Cold	Cold	Cold	Cold	Cold
Noise Level	d(BA)	44	45	47	47	49
Adjustable Feet		•	•	•	•	•
Rinse-Aid Indicator		•	•	•	•	•
Salt Indicator		•	•	•	•	•
Removable Cutlery Basket		•	•	•	•	•
POWER, CONSUMPTION AND VOLTAGE						
Water Consumption	L	9	9	9	11	11
Electrical Current	A	10	10	10	10	10
Voltage / Frequency	V / Hz	220-240V / 50Hz	220-240 / 50	220-240 / 50	220-240 / 50	220-240 / 50
Annual Energy Consumption	kWh	188	211	211	211	211
Annual Water Consumption	L	2520	2520	2520	3080	3080
PROGRAMMES						
Programme 1		Eco 50°C	Eco 50°C	Eco 50°C	Eco 50°C	Eco 50°C
Programme 2		QuickWash 14'	QuickWash 14'	Prewash	Prewash	Prewash
Programme 3		Quick 30'	Quick 30'	Quick 30'	Intensive 65°C	Intensive 65°C
Programme 4		Express 50'	Express 50'	Express 50'	Quick 30'	-
Programme 5		Auto Delicate 30-50	Auto Delicate 30-50	Auto Delicate 30-50	Express 50'	-
Programme 6		Auto Intensive 50-70	Auto Normal 50-60	Auto Normal 50-60	Delicate 40°C	-
Programme 7		Dual Pro Wash	Auto Intensive 60-70	Auto Intensive 60-70	Daily 60°C	-
Programme 8		Hygiene 60°C	Hygiene 60°C	Hygiene 70°C	Hygiene 70°C	-
Programme 9		-	-	-	-	-
Programme 10		-	-	-	-	-
DIMENSIONS AND WEIGHT						
Unpacked dimensions	cm	85 x 59.8 x 45	85 x 59.8 x 45	85 x 59.8 x 45	85 x 59.8 x 45	85 x 59.8 x 45
Product Weight Unboxed (net)	kg	32	32	32	32	32

Specifications / BI Dishwasher Fullsize 60 cm



MODEL NAME	UNIT	QW-GD54R443X	QW-GD53I443X	QW-GD52I472X	QW-D4I1472X	QW-D2I1492X
Description		Fullsize Built-in Dishwasher	Fullsize Built-in Dishwasher	Fullsize Built-in Dishwasher	Fullsize Built-in Dishwasher	Fullsize Built-in Dishwasher
KEY FEATURES						
Cleaning Performance		A	A	A	A	A
Drying Performance		A	A	A	A	A
Number of Place Settings		15	15	15	13	13
Number of Racks		3	3	3	2	2
Number of Programmes		8	8	8	9	5
Energy Efficiency		A+++	A+++	A++	A++	A++
Dishwasher Type		Integrated 60 cm	Integrated 60 cm	Integrated 60 cm	Integrated 60 cm	Integrated 60 cm
WaterBlade & AquaGlide		•	-	-	-	-
Quick Wash Duration	mins	QuickWash 14'	QuickWash 14'	QuickWash 14'	Quick 30'	Quick 30'
Drying System		Turbo	Turbo	Turbo	Active	Active
Water Consumption	L	9	9	9	9	12
OTHER FEATURES						
Advanced Inverter Motor		•	•	-	-	-
Graphic Displays		•	•	•	•	-
Built-in Appliance		•	•	•	•	•
IntelliWash		•	•	•	•	-
AutoDoor		•	•	-	-	-
EcoBox		-	-	-	-	-
MicroBan		•	•	•	•	•
Extra Silent Option		•	•	-	-	-
Extra Fast Option		•	•	-	-	-
Adjustable Upper Basket When Empty		Adj. When Loaded	Adj. When Loaded	Adj. When Loaded	Adj. When Loaded	Adj. When Loaded
Number of Mug Shelves		4 Adj. Mugshelf	4 Adj. Mugshelf	4 Adj. Mugshelf	4 Adj. Mugshelf	4 Adj. Mugshelf
Foldable Racks on Upper Basket		V2 Peg Type 6 Foldable Racks	V2 Peg Type 6 Foldable Racks	V2 Peg Type 6 Foldable Racks	V2 Peg Type Fixed Racks	V2 Peg Type Fixed Racks
Foldable Racks on Lower Basket		4 Fold. Racks	4 Fold. Racks	4 Fold. Racks	4 Fold. Racks	4 Fold. Racks
DualProWash		•	•	-	-	-
Child Lock		-	-	-	-	-
EcoWash		•	•	•	•	-
HygieneWash		•	•	•	•	-
Express 50		•	•	•	-	•
Thirty Minute Wash		•	•	•	•	•
Delay Timer		•	•	•	•	•
SuperQuiet		-	-	-	-	-
Interior LED Lighting		•	•	-	-	-
Overflow and Leakage Protection		•	•	•	•	•
FlexiTray		•	•	•	-	-
Extra Hygiene Option		-	-	-	-	-
Extra Dry Option		-	-	-	-	-
Half Load Option		• (3 modes)	• (3 modes)	• (3 modes)	• (3 modes)	-
Number of Spray Arms		2 + extra top nozzle	2 + extra top nozzle	2 + extra top nozzle	2	2
Washing Cycle Indicator		-	-	-	-	-
Water Inlet		Cold	Cold	Cold	Cold	Cold
Noise Level	d(BA)	44	44	47	47	49
Adjustable Feet		•	•	•	•	•
Rinse-Aid Indicator		•	•	•	•	•
Salt Indicator		•	•	•	•	•
Removable Cutlery Basket		•	•	•	•	•
POWER, CONSUMPTION AND VOLTAGE						
Water Consumption	L	9	9	9	9	12
Electrical Current	A	10	10	10	10	10
Voltage / Frequency	V / Hz	220-240V / 50Hz	220-240V / 50Hz	220-240V / 50Hz	220-240V / 50Hz	220-240V / 50Hz
Annual Energy Consumption	kWh	239	239	267	261	261
Annual Water Consumption	L	2520	2520	2520	2520	3360
PROGRAMMES						
Programme 1		Eco 50°C	Eco 50°C	Eco 50°C	Eco 50°C	Eco 50°C
Programme 2		Quick 30'	Quick 30'	Quick 30'	Quick 30'	Quick 30'
Programme 3		Express 50'	Express 50'	Express 50'	Prewash	Express 50'
Programme 4		QuickWash 14'	QuickWash 14'	QuickWash 14'	Auto Delicate 30-50	Prewash
Programme 5		Auto Delicate 30-50	Auto Delicate 30-50	Auto Delicate 30-50	Auto Normal 50-60	Intensive 70 °C
Programme 6		Auto Intensive 50-70	Auto Intensive 50-70	Auto Normal 50-60	Auto Intensive 60-70	-
Programme 7		Dual Pro Wash	Dual Pro Wash	Auto Intensive 60-70	Super 55' 60 °C	-
Programme 8		Hygiene 60°C	Hygiene 60°C	Hygiene 60°C	Hygiene 60°C	-
Programme 9		-	-	-	Extra Hygiene 70°C	-
Programme 10		-	-	-	-	-
DIMENSIONS AND WEIGHT						
Unpacked dimensions	cm	85 x 59.8 x 59.8	85 x 59.8 x 59.8	85 x 59.8 x 59.8	85 x 59.8 x 59.8	85 x 59.8 x 59.8
Product Weight Unboxed (net)	kg	38	38	38	38	38

Notes

SHARP

Be Original.

Home Appliances | www.sharphomeappliances.com